

# Technical Report Lamaque Complex Québec, Canada

UTM coordinates

Between 295,700 mE and 296,900 mE, and between 5,328,200 mN and 5,329,350 mN

Effective Date: December 31, 2024

Prepared by:  
Eldorado Gold Corporation  
1188 Bentall 5 - 550 Burrard Street  
Vancouver, BC V6C 2B5

## Qualified Persons

D Sutherland  
J Simoneau  
P Lind  
J Thelland  
P Groleau  
M Bouanani  
V Tran

## Company

Eldorado  
Eldorado  
Eldorado  
Eldorado  
Eldorado  
Eldorado  
Eldorado

## Table of Contents

<b>1</b>	<b>Summary .....</b>	<b>1-1</b>
1.1	Introduction .....	1-1
1.2	Contributors and Qualified Persons .....	1-4
1.3	Reliance on Other Experts .....	1-4
1.4	Property Description and Ownership.....	1-4
1.5	Accessibility, Climate, Local Resources, Infrastructure and Physiography.....	1-7
1.6	History .....	1-7
1.7	Geology and Mineralization .....	1-7
1.8	Deposit Types.....	1-9
1.9	Exploration .....	1-9
1.10	Drilling, Sampling Method, Approach and Analyses.....	1-9
1.11	Sample Preparation, Analyses and Security .....	1-10
1.12	Data Verification .....	1-10
1.13	Metallurgical Testing .....	1-10
1.14	Mineral Resource Estimate .....	1-11
1.15	Mineral Reserve Estimates.....	1-13
1.16	Mining Methods .....	1-14
1.17	Process Plant and Recovery Methods .....	1-15
1.18	Infrastructure .....	1-15
1.19	Market Studies and Contracts .....	1-16
1.20	Environment and Permitting .....	1-16
1.21	Capital and Operating Costs .....	1-17
1.22	Financial Analysis .....	1-18
1.23	Adjacent Properties .....	1-18
1.24	Other Relevant Data and Information Opportunities .....	1-18
1.25	Interpretation and Conclusion .....	1-21
1.26	Recommendations .....	1-22
<b>2</b>	<b>Introduction.....</b>	<b>2-1</b>
2.1	Principal Sources of Information.....	2-2
2.2	Qualified Persons and Inspection on the Project .....	2-2
2.3	Site Visits .....	2-3
2.4	Effective Date .....	2-3
2.5	Abbreviations, Units, and Currencies .....	2-3
<b>3</b>	<b>Reliance on Other Experts.....</b>	<b>3-1</b>
3.1	Property Agreements, Mineral Tenure, Surface Rights, and Royalties .....	3-1
3.2	Political .....	3-1
3.3	Environmental, Permitting, Closure, Social, and Community .....	3-1
3.4	Taxation .....	3-1
3.5	Markets.....	3-1
<b>4</b>	<b>Property Description and Location.....</b>	<b>4-1</b>
4.1	Location .....	4-1
4.2	Property Description.....	4-1

<b>5</b>	<b>Accessibility, Climate, Local Resources, Infrastructure and Physiography.....</b>	<b>5-1</b>
5.1	Accessibility .....	5-1
5.2	Climate .....	5-2
5.3	Local Resources and Infrastructures.....	5-5
5.4	Physiography .....	5-5
<b>6</b>	<b>History .....</b>	<b>6-1</b>
6.1	History of the Sigma and Lamaque Mines.....	6-1
6.2	Lamaque Project Exploration History .....	6-4
6.3	Eldorado.....	6-6
<b>7</b>	<b>Geological Setting and Mineralization.....</b>	<b>7-1</b>
7.1	Regional Geological Setting of the Abitibi Greenstone Belt.....	7-1
7.2	District Geology .....	7-2
7.3	Local Geological Setting and Mineralization.....	7-5
<b>8</b>	<b>Deposit Types .....</b>	<b>8-1</b>
8.1	Orogenic Gold Deposits .....	8-1
<b>9</b>	<b>Exploration .....</b>	<b>9-1</b>
9.1	Property Scale Exploration .....	9-1
9.2	South-West Target and Gabbro South.....	9-2
9.3	Sigma East Extension.....	9-3
9.4	Aumaque Block .....	9-3
9.5	Secteur Nord.....	9-4
<b>10</b>	<b>Drilling .....</b>	<b>10-1</b>
<b>11</b>	<b>Sample Preparation, Analyses, and Security .....</b>	<b>11-1</b>
11.1	Sample Preparation, Analyses.....	11-1
11.2	Quality Assurance and Quality Control .....	11-1
11.3	Concluding Statement.....	11-7
<b>12</b>	<b>Data Verification .....</b>	<b>12-8</b>
12.1	Drill Data Handling and Security .....	12-8
12.2	Data Verification by Qualified Persons .....	12-8
<b>13</b>	<b>Mineral Processing and Metallurgical Testing .....</b>	<b>13-1</b>
13.1	Initial Testwork on Plug 4, Triangle, Parallel, and Fortune Composites.....	13-1
13.2	Triangle Composite Testwork.....	13-5
13.3	Triangle Zone Testwork.....	13-6
13.4	Comminution Testwork .....	13-14
13.5	Lower Triangle (Zones C8 through C10) and Ormaque.....	13-14
13.6	Ormaque Metallurgical Testwork.....	13-17
13.7	Results, Summary, and Conclusions.....	13-23
<b>14</b>	<b>Mineral Resource Estimates.....</b>	<b>14-1</b>
14.1	Triangle Deposit .....	14-1
14.2	Parallel Deposit .....	14-17
14.3	Plug No. 4.....	14-27
14.4	Ormaque Deposit .....	14-30

<b>15</b>	<b>Mineral Reserve Estimates .....</b>	<b>15-1</b>
15.1	Factors that May Affect Mineral Reserves .....	15-2
15.2	Underground Resource Estimates .....	15-2
15.3	Mineral Reserve Estimate .....	15-3
15.4	Qualified Person Comment on Reserve Estimate .....	15-4
<b>16</b>	<b>Mining Methods .....</b>	<b>16-1</b>
16.1	Introduction .....	16-1
16.2	Mineable Resource Summary .....	16-2
16.3	Mine Plan .....	16-2
16.4	Underground Mine Design .....	16-11
16.5	Mine Backfill .....	16-17
16.6	Productivity Rates .....	16-19
16.7	Mine Development and Production Schedule .....	16-21
16.8	Mine Equipment .....	16-25
16.9	Ventilation .....	16-26
16.10	Geotechnical Assessment .....	16-27
16.11	Mine Services .....	16-34
<b>17</b>	<b>Recovery Methods .....</b>	<b>17-1</b>
17.1	Introduction .....	17-1
17.2	Metallurgical Recoveries .....	17-5
17.3	Water Balance .....	17-5
17.4	Process Equipment .....	17-6
17.5	Design Criteria .....	17-7
17.6	Power Reagents and Consumables .....	17-8
17.7	Plant Personnel .....	17-9
17.8	Plant Layout .....	17-11
<b>18</b>	<b>Project Infrastructure .....</b>	<b>18-1</b>
18.1	Site Access and Logistics .....	18-1
18.2	Site Infrastructure .....	18-1
18.3	Site Development .....	18-2
18.4	Local Infrastructure .....	18-4
18.5	Triangle Mine Site .....	18-4
18.6	Ormaque Mine - Infrastructure Additions .....	18-7
18.7	Sigma Mill Complex .....	18-10
18.8	Support Infrastructure .....	18-11
18.9	Material Stockpiling .....	18-12
18.10	Tailings Strategy .....	18-14
18.11	Water Management .....	18-18
18.12	Paste Backfill Plant .....	18-20
<b>19</b>	<b>Market Studies and Contracts .....</b>	<b>19-1</b>
19.1	Market .....	19-1
19.2	Contracts .....	19-1
<b>20</b>	<b>Environmental Studies, Permitting and Social or Community Impact .....</b>	<b>20-1</b>

20.1	Regulations and Permitting .....	20-1
20.2	Consultation Activities and Social Economic Setting .....	20-6
<b>21</b>	<b>Capital and Operating Costs .....</b>	<b>21-1</b>
21.1	Mineral Reserve Capital Costs .....	21-1
21.2	Mineral Reserve Operating Costs .....	21-4
<b>22</b>	<b>Economic Analysis .....</b>	<b>22-1</b>
22.1	Reserve Economic Modelling Parameters .....	22-1
<b>23</b>	<b>Adjacent Properties .....</b>	<b>23-1</b>
<b>24</b>	<b>Other Relevant Data and Information .....</b>	<b>24-1</b>
24.1	Summary .....	24-1
24.2	Introduction .....	24-1
24.3	Reliance on Other Expects .....	24-1
24.4	Property Description and Location .....	24-1
24.5	Accessibility, Climate, Local Resources, Infrastructure and Physiography .....	24-1
24.6	History .....	24-2
24.7	Geological Setting and Mineralization .....	24-2
24.8	Deposit Type .....	24-2
24.9	Exploration .....	24-2
24.10	Drilling .....	24-2
24.11	Sample Preparation, Analyses and Security .....	24-2
24.12	Data Verification .....	24-2
24.13	Mineral Processing and Metallurgical Testing .....	24-2
24.14	Mineral Resource Estimates .....	24-3
24.15	Mineral Reserve Estimates .....	24-4
24.16	Mining Methods .....	24-4
24.17	Recovery Methods .....	24-8
24.18	Project Infrastructure .....	24-8
24.19	Market Studies and Contracts .....	24-10
24.20	Environmental Studies, Permitting and Social or Community Impact .....	24-10
24.21	Capital and Operating Costs .....	24-10
24.22	Economic Analysis .....	24-14
24.23	Adjacent Properties .....	24-20
24.24	Interpretation and Conclusions .....	24-20
24.25	Life of Asset Strategy .....	24-20
24.26	Risks and Opportunities .....	24-24
<b>25</b>	<b>Interpretation and Conclusions .....</b>	<b>25-1</b>
25.1	Overview .....	25-1
25.2	Mineral Resources and Mineral Reserves .....	25-2
25.3	Mining Methods .....	25-2
25.4	Metallurgy .....	25-2
25.5	Processing and Paste Backfill .....	25-2
25.6	Tailings Management Facility .....	25-3
25.7	Environmental and Permitting .....	25-3
25.8	Infrastructure .....	25-3

25.9	Capital and Operating Costs, and Financial Modelling .....	25-3
<b>26</b>	<b>Recommendations .....</b>	<b>26-1</b>
26.1	Geology - Exploration .....	26-1
26.2	Mining – Planning and Operational .....	26-1
26.3	Metallurgy and Processing .....	26-1
26.4	Permitting and Closure.....	26-2
26.5	Budget.....	26-2
<b>27</b>	<b>References .....</b>	<b>27-1</b>
<b>28</b>	<b>Date and Signature Page .....</b>	<b>28-1</b>

## List of Figures

Figure 1-1: Lamaque Complex Mill Production Comparisons .....	1-3
Figure 1-2: Sigma Mill Gold Production Comparisons .....	1-3
Figure 1-3: Location of the Lamaque Property with Respect to the City of Val-d'Or (Eldorado 2024) .....	1-5
Figure 1-4: Location of Property in Relation to Royalties (Eldorado 2024) .....	1-6
Figure 1-5: Geology of the Abitibi Greenstone Belt .....	1-8
Figure 4-1: Location of the Lamaque Complex in the Province of Québec (Eldorado, 2024) .....	4-1
Figure 4-2: Claim Map of the Lamaque Complex Near Val-d'Or, Québec, Canada (Eldorado, 2024) .....	4-2
Figure 4-3: Location of the Lamaque Complex with Respect to the City of Val-d'Or (Eldorado, 2024) .....	4-6
Figure 4-4: Location of Historical Properties in Relation to Royalties (Eldorado, 2024) .....	4-8
Figure 5-1: Access and Waterways of the Lamaque Complex and Region (Eldorado 2024) .....	5-1
Figure 5-2: Location and Access of the Lamaque Complex (Eldorado 2024) .....	5-2
Figure 7-1: Geology of the Abitibi Greenstone Belt .....	7-2
Figure 7-2: Simplified Geology of Lamaque and Bourlamaque Areas (based on Sauv� et al., 1993) .....	7-4
Figure 7-3: Geology of the Lamaque Complex Area (Eldorado 2024) .....	7-7
Figure 7-4: Composite Section Looking West through the Triangle, Plug No. 4, Ormaque, Parallel, Lamaque and Sigma Deposits (Eldorado 2022) .....	7-8
Figure 9-1: Geology of the Lamaque Project Area (Eldorado 2024) .....	9-2
Figure 10-1: Triangle Deposit Drillhole Location Map (Eldorado 2024) .....	10-4
Figure 10-2: Triangle Deposit Underground Drillhole Location Map (Eldorado 2024) .....	10-5
Figure 10-3: Plug No. 4 Deposit Drillhole Location Map (Eldorado 2024) .....	10-6
Figure 10-4: Parallel Deposit Drillhole Location Map (Eldorado 2024) .....	10-7
Figure 10-5: Ormaque Deposit Drillhole Location Map (Eldorado 2024) .....	10-8
Figure 11-1: Lamaque Blank Data – 2019 to 2024 (Eldorado) .....	11-2
Figure 11-2: SRM Chart for Standard 26 (Oreas 216), 2017 to 2023 (Eldorado) .....	11-4
Figure 11-3: SRM Chart for Standard 44 (Oreas 239b), 2023 to 2024 (Eldorado) .....	11-5
Figure 11-4: Relative Difference Plot of Gold Duplicate Data, 2017 to 2024 (Eldorado) .....	11-6
Figure 11-5: Q-Q Plot for Gold Duplicate Data, 2017 to 2024 (Eldorado) .....	11-7
Figure 13-1: Grind Size vs Gold Recovery .....	13-16
Figure 13-2: Leach Kinetics for Ormaque Variability Samples .....	13-21
Figure 13-3: Impact of Principal Variables on Ormaque Composite Recovery .....	13-22
Figure 14-1: 3D View of the Modeled Resource Solids Associated with the Main Shear Zones and their Associated Splay Zones at Triangle (Eldorado 2024) .....	14-2
Figure 14-2: Lower Central Portion of C4 Zone Showing Block Model Grade and Composites (Eldorado 2024) .....	14-10
Figure 14-3: Upper Portion of C5 Shear Zone Showing Block Model Grades and Composites (Eldorado 2024) .....	14-11
Figure 14-4: C4-30 Splay Zone Showing Block Model Grades and Composites (Eldorado 2024) .....	14-12
Figure 14-5: Model Trend Plots Showing 5 m Binned Averages Along Elevations & Eastings for Kriged (Au) & Nearest Neighbour Gold Grade Estimates, C4 Main Zone, Triangle Deposit (Eldorado 2024) .....	14-14
Figure 14-6: Model Trend Plots Showing 5 m Binned Averages Along Elevations and Eastings for Kriged and Nearest Neighbour Gold Grade Estimates, C5 Main Zone, Triangle Deposit (Eldorado 2024) .....	14-15
Figure 14-7: 3D Sectional View Looking East of the Modeled Resource Solids Extension / Shear Zones at Parallel (Eldorado 2024) .....	14-18
Figure 14-8: 3D Plan View of the Modelled Resource Solids Extension / Shear Zones at Parallel (Eldorado 2024) .....	14-19
Figure 14-9: Zone 30 Showing Gold Composite Data and Gold Block Model (Eldorado 2024) .....	14-22

Figure 14-10: Zone 20 Showing Gold Composite Data and Gold Block Model (Eldorado 2024) .....	14-23
Figure 14-11: Model Trend Plots Showing 5 M Binned Averages Along Elevations and Eastings for Au (IDW) and Nearest Neighbour Gold Grade Estimates, Parallel Deposit (Eldorado 2024) .....	14-25
Figure 14-12: 3D Sectional View of the Modelled Resource Solids at Plug No. 4 (Eldorado 2024) .....	14-28
Figure 14-13: 3D Sectional View Looking North of the Modelled Resource Solids Associated with the Extension Zones at Ormaque (Eldorado 2024) .....	14-31
Figure 14-14: Zone E0100 Showing Gold Composite Data and Gold Block Model (Eldorado 2024) .....	14-38
Figure 14-15: Zone E070 Showing Gold Composite Data and Gold Block Model (Eldorado 2024) .....	14-39
Figure 14-16: Zone E260 Showing Gold Composite Data and Gold Block Model (Eldorado 2024) .....	14-39
Figure 14-17: Model Trend Plots Showing 5 m Binned Averages Along Elevations and Eastings for Kriged (Au) and Nearest Neighbour Gold Grade Estimates, E070 Zone, Ormaque Deposit (Eldorado 2024) .....	14-42
Figure 14-18: Model Trend Plots Showing 5 m Binned Averages Along Elevations and Eastings for Kriged (Au) and Nearest Neighbour Gold Grade Estimates, E090 Zone, Ormaque Deposit (Eldorado 2024) .....	14-43
Figure 16-1: Isometric View of the Lamaque Complex Deposits and Mine Planning Schematics (Eldorado 2024) .....	16-1
Figure 16-2: Longitudinal Longhole Stopping (typical example, Eldorado 2024) .....	16-4
Figure 16-3: Sublevel plan view example of a PSLS (Eldorado 2024) .....	16-5
Figure 16-4: Primary-Secondary Transverse Longhole Stopping, (typical example, Eldorado 2024) .....	16-6
Figure 16-5: Illustration of Uppers Longhole Stopping (typical example, Eldorado 2024) .....	16-7
Figure 16-6: Illustration of a Sill Pillar (typical example, Eldorado 2024) .....	16-8
Figure 16-7: Typical DAF Mining Level (Eldorado 2024) .....	16-9
Figure 16-8: Plan View - Triangle Ramp Portal Location (Source: Google Earth, 2024 image) .....	16-11
Figure 16-9: Sigma-Triangle Decline Portal Location (Source: Google Earth, 2024 image) .....	16-12
Figure 16-10: Mine Design with Ramps and Existing Development in Black (Eldorado 2024) .....	16-15
Figure 16-11: Mining Zones, Looking North-East (Eldorado 2024) .....	16-16
Figure 16-12: Typical Triangle Sublevel Layout (Eldorado 2024) .....	16-16
Figure 16-13: Ormaque MI&I Design Longitudinal View Looking East (Eldorado 2024) .....	16-17
Figure 16-14: Ormaque Paste Reticulation Network (Eldorado 2024) .....	16-19
Figure 16-15: Conceptual Primary-Secondary Mining Sequence of Blocks (Eldorado 2024) .....	16-21
Figure 16-16: Total Annual Development Metres by Deposit (Eldorado 2024) .....	16-22
Figure 16-17: Total Annual Development Metres by Cost Centre (Eldorado 2024) .....	16-23
Figure 16-18: Mines Production Profile (Eldorado 2024) .....	16-24
Figure 16-19: Distribution of Ounces by Mining Method (Eldorado 2024) .....	16-24
Figure 16-20: Ventilation Network for Lamaque Complex (Eldorado 2024) .....	16-27
Figure 16-21: Field Strength Distribution per Domain (Eldorado 2024) .....	16-31
Figure 16-22: UCS Lab Tests (Eldorado 2024) .....	16-32
Figure 16-23: RMR Distribution per Domain (Eldorado 2024) .....	16-33
Figure 16-24: Cross-section Showing Information used for Preliminary Structural Model (ASA Geotech 2024) .....	16-33
Figure 16-25: Typical Decant Drifts (Eldorado 2024) .....	16-35
Figure 16-26: Typical Primary Pump Station (Eldorado 2024) .....	16-36
Figure 16-27: Typical Borehole Sump (Eldorado 2024) .....	16-37
Figure 17-1: Sigma Mill Simplified Flowsheet (Eldorado 2024) .....	17-2
Figure 17-2: High-Level Mill Water Schematic (Eldorado 2024) .....	17-6
Figure 17-3: High-Level Mill Water Schematic – Future (Eldorado 2024) .....	17-6
Figure 17-4: Process Plant Aerial Photo (Google Earth 2023) .....	17-11
Figure 18-1: Triangle Mine Operation (Eldorado 2024) .....	18-3

Figure 18-2: Sigma Mill and Decline Portal (Eldorado 2024) .....	18-3
Figure 18-3: Ormaque Surface Infrastructure (Eldorado 2024) .....	18-7
Figure 18-4: Dewatering System Network (Eldorado 2024).....	18-9
Figure 18-5: Ormaque Main Ventilation Network (Eldorado 2024) .....	18-10
Figure 18-6: Ormaque Waste Rock – Planned (Eldorado 2024) .....	18-13
Figure 18-7: View of the existing Sigma Tailings Storage Facility (Eldorado 2024) .....	18-15
Figure 18-8: Sigma Tailings Storage Facility Phase 7 (Eldorado 2024) .....	18-16
Figure 18-9: View of the existing Sigma Tailings Storage Facility at Completion (Eldorado 2024) .....	18-17
Figure 18-10: Lamaque TSF – Current Site Plan View (Eldorado 2024) .....	18-18
Figure 18-11: Overall Water Management Schematic - Future State .....	18-19
Figure 18-12: Conceptual Water Treatment for Ammonia Removal from Mine Dewatering (Eldorado 2024).....	18-20
Figure 18-13: Paste Plant Simplified Flowsheet (Eldorado 2024).....	18-22
Figure 18-14: Proposed Ormaque Paste Backfill Reticulation Network (Eldorado 2024).....	18-23
Figure 22-1: Annual Ore Processed and Gold Produced (Eldorado 2024).....	22-4
Figure 22-2: Sensitivity of the Net Present Value (after-tax) to Cost Inputs (Eldorado 2024).....	22-7
Figure 22-3: Recovery Sensitivity (Eldorado 2024).....	22-7
Figure 24-1: Incremental Annual Mine Production Profile PEA LOM (Eldorado 2024).....	24-6
Figure 24-2: Proposed Lamaque Tailings Storage Facility Plan View (Eldorado 2024) .....	24-9
Figure 24-3: Annual Mineralized Material Mined by Deposit, PEA Case (Eldorado 2024) .....	24-16
Figure 24-4: PEA Sensitivity of the Net Present Value (5% discount rate, after-tax) to Gold Price (Eldorado 2024).....	24-20
Figure 24-5: Mineral Occurrences within the Lamaque Property and Bourlamaque Property (Eldorado 2024).....	24-22

### List of Tables

Table 1-1: Summary of Drilling on the Sigma-Lamaque Block Deposits .....	1-10
Table 1-2: Triangle Mineral Resources, as of September 30, 2024.....	1-11
Table 1-3: Parallel Mineral Resources, as of September 30, 2024.....	1-12
Table 1-4: Plug No. 4 Mineral Resources, as of September 30, 2024.....	1-12
Table 1-5: Ormaque Mineral Resources, as of September 30, 2024.....	1-13
Table 1-6: Lamaque Complex Mineral Reserves as of September 30, 2024 .....	1-14
Table 1-7: Lamaque Complex Mineral Gold Production during Q4 2024 .....	1-14
Table 1-8: Capital Cost Estimate.....	1-17
Table 1-9: Operating Cost Summary.....	1-17
Table 1-10: Summary of Incremental Mineralized Material compared to Mineral Reserves .....	1-19
Table 1-11: Longhole Mining Mucking Rates .....	1-19
Table 1-12: PEA LOM Development Schedule .....	1-19
Table 1-13: Growth Capital Items, PEA Case .....	1-20
Table 1-14: Operating Cost Summary.....	1-20
Table 1-15: Proposed Work Program and Budget .....	1-22
Table 4-1 Lamaque Project Mining Lease, Mining Concessions and Exploration Claims .....	4-3
Table 4-2: Royalties Summary Table .....	4-7
Table 4-3: Remediation and Reclamation Plans .....	4-9
Table 5-1: Distribution of Annual Climate Data for the Period 1981 to 2010 .....	5-3
Table 5-2: Rainfall (mm) Depth-Duration-Frequency at Val-d’Or Airport (Period 1961 through 2017).....	5-4
Table 5-3: Rainfall (mm) Depth-Duration-Frequency at Val-d’Or Airport (Period 1951 through 2016).....	5-4

Table 5-4: Projections of Temperature and Precipitation in the Horizon of 2041 through 2070 .....	5-4
Table 6-1: Total 1935-1985 Production Figures for the Lamaque Mine Principal Mining Areas.....	6-2
Table 6-2: Total Production from the Sigma and Lamaque Mines to End of May 2012 .....	6-4
Table 6-3: Indicated Mineral Resources, Integra Gold 2017 Technical Report .....	6-5
Table 6-4: Inferred Mineral Resources Estimate, Integra Gold 2017 Technical Report .....	6-6
Table 6-5: Lamaque Mineral Resource Estimate, as of December 31, 2017 .....	6-6
Table 6-6: Lamaque Project Mineral Reserve Estimates, as of December 31, 2017 .....	6-7
Table 6-7: Lamaque Project Mineral Resource Estimates, as of September 30, 2021 .....	6-8
Table 6-8: Lamaque Project Mineral Reserve Estimates as of September 30, 2021 .....	6-8
Table 6-9: Lamaque Complex Production, 2017 to 2023 (Eldorado, 2024).....	6-9
Table 10-1: Summary of Triangle Deposit Drilling.....	10-1
Table 10-2: Summary of Plug No. 4 Deposit Drilling (Resource Eligible Holes Only) .....	10-1
Table 10-3: Summary of Parallel Deposit Drilling.....	10-2
Table 10-4: Summary of Ormaque Deposit Drilling.....	10-2
Table 11-1: Standard Reference Material Samples Used at Lamaque Project, 2015 to 2024 .....	11-3
Table 13-1: Head Assays Summary.....	13-2
Table 13-2: Gravity Concentration and Cyanide Leach - Conditions and Recoveries.....	13-3
Table 13-3: Summary of Flotation Gold Recoveries Obtained.....	13-3
Table 13-4: Summary of Chemical Assays .....	13-4
Table 13-5: Gold Recovery by Flowsheet .....	13-5
Table 13-6: Triangle Zone Composites Head Assays Summary .....	13-5
Table 13-7: Overall Gold Recovery Summary.....	13-6
Table 13-8: Assembly of Composite Samples .....	13-7
Table 13-9: Selected Head Assays from Triangle Deposit Samples .....	13-7
Table 13-10: Rod Mill and Ball Mill Work Indexes.....	13-8
Table 13-11: Ball Mill Work Index Variability Samples .....	13-8
Table 13-12: Bond Ball Mill Work Index Drill Core Results .....	13-8
Table 13-13: Baseline Leach Test Results.....	13-9
Table 13-14: C1, C2, C4 and C5 Ore Samples Variability Test Results .....	13-11
Table 13-15: Solids Liquid Separation Testing Sample Characteristics .....	13-12
Table 13-16: Recommended Thickening Design Parameters .....	13-12
Table 13-17: Thickener Underflow Apparent Viscosities and Yield Stress .....	13-13
Table 13-18: Summary of Vacuum Filtration Test Results.....	13-13
Table 13-19: Summary of Pressure Filtration Test Results.....	13-14
Table 13-20: Comminution Testing Results .....	13-14
Table 13-21: Summary of Selected Head Assay Results .....	13-15
Table 13-22: Bond Ball Mill Work Index Results .....	13-15
Table 13-23: Selected Carbon-In-Pulp Results, Baseline 35 mm P <sub>80</sub> .....	13-16
Table 13-24: Selected E-GRG Results.....	13-17
Table 13-25: Ormaque Metallurgical Samples .....	13-17
Table 13-26: Host Rock (Waste) Samples .....	13-18
Table 13-27: Head Characterization of Ormaque Samples .....	13-18
Table 13-28: XRD Characterization of Ormaque Samples .....	13-18
Table 13-29: Ormaque Composite Comminution Results.....	13-19
Table 13-30: Ormaque Waste Rock Grindability Results.....	13-19
Table 13-31: Extended Gravity Recoverable Gold (E-GRG) Results .....	13-19
Table 13-32: Ormaque Variability Cyanidation Results.....	13-20

Table 13-33: Ormaque Composite Optimization Results .....	13-21
Table 13-34: Acid Base Accounting Test Results .....	13-23
Table 14-1: Triangle Deposit Composite Statistics for 1 m Uncapped Composite Au (g/t) Data .....	14-2
Table 14-2: Triangle Deposit Composite Statistics for 1 m Capped Composite Au (g/t) Data .....	14-3
Table 14-3: Variogram Parameters for Triangle Zones .....	14-5
Table 14-4: Block Model Limits and Block Size .....	14-5
Table 14-5: Estimation for Triangle Domains .....	14-6
Table 14-6: Global Model Mean Gold (g/t) Values by Mineralized Domain, Triangle Deposit .....	14-13
Table 14-7: Triangle Mineral Resources, as of September 30, 2024 .....	14-16
Table 14-8: Triangle Mineral Resources, as of September 30, 2024 .....	14-16
Table 14-9: Parallel Deposit Composite Statistics for 1 m Uncapped Composite Au (g/t) Data .....	14-20
Table 14-10: Parallel Deposit Composite Statistics for 1 m Capped Composite Au (g/t) Data .....	14-20
Table 14-11: Block Model Limits and Block Size in Parallel Deposit .....	14-21
Table 14-12: Global by Mineralized Domain, Parallel Deposit Model Mean Gold Values .....	14-24
Table 14-13: Parallel Mineral Resources, as of September 30, 2024 .....	14-26
Table 14-14: Plug No. 4 Assay Statistics by Zone (Uncapped Au (g/t) Data) .....	14-28
Table 14-15: Plug No. 4 Composite Statistics by Zone (Capped Au (g/t)) .....	14-29
Table 14-16: Plug No. 4 Mineral Resources, as of September 30, 2024 .....	14-30
Table 14-17: Ormaque Composite Statistics for 0.5 m Uncapped Composite Au (g/t) Data .....	14-32
Table 14-18: Ormaque Composite Statistics for 0.5 m Capped Composites of Au (g/t) Data (70 g/t capping) .....	14-33
Table 14-19: Variogram Parameters for Ormaque Mineralization Zones .....	14-35
Table 14-20: Block model Limits and block definitions .....	14-36
Table 14-21: Estimation Plan for Ormaque Zones .....	14-36
Table 14-22: Global Model Mean Gold Values by Mineralized Domain, Ormaque Deposit .....	14-40
Table 14-23: Ormaque Mineral Resources, as of September 30, 2024 .....	14-44
Table 14-24: Ormaque Mineral Resources breakdown by zone, as of September 30, 2024 .....	14-44
Table 15-1: Long Hole Cut-off Grade Definition (Triangle and Parallel deposits) .....	15-1
Table 15-2: Drift-And-Fill Cut-off Grade Definition (Ormaque deposit) .....	15-1
Table 15-3: Lamaque Complex Mineral Reserves as of September 30, 2024 .....	15-4
Table 15-4: Lamaque Complex Mineral Gold Production during Q4 2024 .....	15-4
Table 16-1: Mineralized and Waste Rock Average In-Situ Densities .....	16-2
Table 16-2: Mine Design Criteria: Longitudinal Longhole Stopping .....	16-4
Table 16-3: Mine Design Criteria: Transverse Longhole Stopping .....	16-6
Table 16-4: Mine Design Criteria: Uppers Longhole Stopping .....	16-7
Table 16-5: Mine Design Criteria: Sill Pillar Longhole Stopping .....	16-8
Table 16-6: Drift-and-Fill Mining Criteria .....	16-10
Table 16-7: External Dilution Factors .....	16-10
Table 16-8: Mining Recovery Factors .....	16-10
Table 16-9: Lateral Development Criteria .....	16-12
Table 16-10: Vertical Development Criteria .....	16-13
Table 16-11: Overbreak and Design Allowances .....	16-13
Table 16-12: Development Quantities for Case 1 .....	16-14
Table 16-13: Development Quantities for Case 2 .....	16-14
Table 16-14: Effective Work Hours per Shift .....	16-19
Table 16-15: Development Advance Rates .....	16-20
Table 16-16: Longhole Mining Mucking Rates .....	16-20

Table 16-17: Annual Summary of Waste and Mineralized Tonnes .....	16-21
Table 16-18: Life of Mine Development Schedule .....	16-22
Table 16-19: Mine Production Schedule .....	16-23
Table 16-20: Lamaque Complex Mobile Equipment List.....	16-25
Table 16-21: Geomechanical Properties of Triangle Diorite / Tuff .....	16-28
Table 16-22: Hoek-Brown and Mohr-Coulomb parameters .....	16-29
Table 16-23: Regional Natural Stresses .....	16-30
Table 16-24: Major and Minor Structures Families .....	16-30
Table 16-25: Ground Support Parameters .....	16-30
Table 17-1: Major Equipment List.....	17-6
Table 17-2: Design Criteria.....	17-7
Table 17-3: Consumption of Reagents and Consumables.....	17-9
Table 17-4: Plant Personnel .....	17-10
Table 18-1: Paste Plant Design Criteria Summary.....	18-20
Table 20-1: Remediation and Reclamation Plans .....	20-5
Table 21-1: Capital Cost Estimate .....	21-1
Table 21-2: Growth Capital Items .....	21-2
Table 21-3: Sustaining Capital Items.....	21-3
Table 21-4: Operating Cost Summary.....	21-4
Table 22-1: Mineral Reserves Financial Model Parameters .....	22-2
Table 22-2: Québec Mining Tax Rates.....	22-3
Table 22-3: Financial Analysis Summary (Mineral Reserves) .....	22-4
Table 22-4: Cash Flow Model (Mineral Reserves) .....	22-5
Table 22-5: Production Cost Summary (Mineral Reserves LOM).....	22-6
Table 22-6: Net Present Value (5%) Sensitivity Results (after-tax) .....	22-6
Table 24-1: Bond Ball Mill Work Index Results (75 µm closing screen).....	24-2
Table 24-2: Lamaque Complex Mineral Resources .....	24-3
Table 24-3: Summary of Incremental Mineralized Material in PEA Case .....	24-4
Table 24-4: Longhole Mining Mucking Rates .....	24-5
Table 24-5: Incremental Mineralized Material and Waste Rock Annual Summary PEA LOM.....	24-5
Table 24-6: Incremental Development Schedule PEA LOM .....	24-5
Table 24-7: Lamaque Complex Mobile Equipment List (PEA Case) .....	24-7
Table 24-8: Capital Cost Estimate .....	24-10
Table 24-9: Growth Capital Items, PEA Case .....	24-11
Table 24-10: Sustaining Capital Items.....	24-12
Table 24-11: Operating Cost Summary.....	24-13
Table 24-12: PEA Financial Model Parameters .....	24-15
Table 24-13: PEA Financial Analysis Summary .....	24-17
Table 24-14: PEA Cash Flow Model .....	24-18
Table 24-15: PEA Production Cost Summary .....	24-19
Table 24-16: PEA Sensitivity Analysis (5%) Sensitivity Results (after-tax).....	24-19
Table 24-17: Mineral Occurrences within the Lamaque Property and Bourlamaque Property.....	24-23
Table 24-18: Risk Register .....	24-24
Table 24-19: Opportunity Register .....	24-25
Table 26-1: Proposed Work Program and Budget .....	26-2

## Glossary

### Units of Measure

Annum (year) .....	a
Billion .....	B
Centimeter .....	cm
Cubic centimeter .....	cm <sup>3</sup>
Cubic feet per minute .....	cfm
Cubic meter .....	m <sup>3</sup>
Day .....	d
Days per year (annum) .....	d/a
Degree .....	°
Degrees Celsius .....	°C
Dollar (American) .....	US\$
Dollar (Canadian) .....	CAD\$
Feet .....	ft
Gram .....	g
Grams per litre .....	g/cm <sup>3</sup>
Grams per litre .....	g/L
Grams per tonne .....	g/t
Greater than .....	>
Hectare (10,000 m <sup>2</sup> ) .....	ha
Horsepower .....	h
Hour .....	h
Hour per year (annum) .....	h/a
Kilo (thousand) .....	k
Kilogram .....	kg
Kilograms per cubic meter .....	kg/m <sup>3</sup>
Kilograms per hour .....	kg/h
Kilograms per square meter .....	kg/m <sup>2</sup>
Kilograms per tonne .....	kg/t
Kilometer .....	km
Kilometers per hour .....	km/h
Kilopascal .....	kPa
Kilotonne .....	kt
Kilotonne per annum .....	ktpa
Kilovolt .....	kV
Kilowatt hour .....	kWh
Kilowatt hours per tonne .....	kWh/t
Kilowatt hours per annum .....	kWh/a
Kilowatt .....	kW
Less than .....	<
Litre .....	L
Litre per tonne .....	L/t

Megavolt Ampere.....	MVA
Megawatt .....	MW
Meter.....	m
Meter above Sea Level.....	masl
Metric ton (tonne).....	t
Microns .....	µm
Milligram .....	mg
Milligrams per litre.....	mg/L
Millilitre.....	mL
Millimeter .....	mm
Million cubic meters .....	Mm <sup>3</sup>
Million ounces .....	Moz
Million Pascal.....	MPa
Million tonnes per Annum .....	Mtpa
Million tonnes.....	Mt
Million.....	M
Million Years .....	Ma
Minutes .....	min
Newton.....	N
Newton per square meter (Pascal) .....	N/m <sup>2</sup> or Pa
Ounce .....	oz
Parts per billion .....	ppb
Parts per million .....	ppm
Horsepower	
Percent .....	%
Percent by Weight.....	wt%
Square centimeter.....	cm <sup>2</sup>
Square kilometer.....	km <sup>2</sup>
Square meter .....	m <sup>2</sup>
Thousand cubic feet per minute.....	kcfm
Thousand tonnes .....	kt
Three Dimensional.....	3D
Tonne.....	t
Tonnes per day.....	t/d or tpd
Tonnes per hour.....	tph
Tonnes per cubic meter .....	t/m <sup>3</sup>
Tonnes per operating day .....	tpod
Tonnes per operating hour.....	tpoh
Tonnes per year (annum) .....	tpa
Volt.....	V
Watt .....	W
Weight/volume .....	w/v
Weight/weight .....	w/w

### Abbreviations

AA	atomic absorption
AISC	all-in sustaining cost
BAPE	Bureau des audiences publiques en Environnement
BEV	battery electric vehicle
BV	Bureau Veritas
BWI	ball mill work index
CEAA	Canadian Environmental Assessment Act 2012
CEAAg	Canadian Environmental Assessment Agency
Century Mining	Century Mining Corporation Inc
CIM	Canadian Institute of Mining
CIP	carbon-in-pulp
CN	Canadian National Railroad
CNSC	Canadian Nuclear Safety Commission
CoA	Certificate of Authorizations
CRF	cemented rockfill
CV	coefficients of variation
DAF	drift and fill
Dome Mines	Dome Mines Ltd
EGQ	Eldorado Gold Québec
EQA	Environment Quality Act
ERP	emergency response plan
ESA	environmental and social assessment
FAR	fresh air raise
G&A	general and administration
GCMP	Geotechnical Ground Control Management Plan
Geologica	Geologica Groupe-Conseil Inc
Golden Pond	Golden Pond Resources Ltd
IDF	Rainfall Depth-Duration-Frequency
IRR	internal rate of return
Kalahari	Kalahari Resources Ltd
LHD	load haul dump
LLCFZ	Larder Lake-Cadillac fault zone
LLS	Longitudinal Longhole Stoping
LOM	life of mine
LV	low voltage
McWatters	McWatters Mining Ltd
MELCC	Ministère de l'environnement et Lutte Contre le Changement Climatiques
MERN	Ministry of Energy and Natural Resources
MFFP	Ministère de Forêts, Faune et Parcs
MLC	mine load center
MRE	Mineral Resource Estimate
MV	medium voltage
NFM	National Filter Media
NI 43-101	National Instrument 43-101 Standards of Disclosure for Mineral Projects
NPV	net present value
NSR	net smelter return
NTS	Canadian National Topographical System
OHS	Occupational Health and Safety
OK	ordinary kriging
PAX	Potassium Amyl Xanthate
PEA	preliminary economic assessment
PSLS	Primary-secondary longhole stoping

QA/QC	quality assurance and control
QMX	QMX Gold Corporation
QP	qualified person
RRP	Reclamation and Remediation Plan
Sigma Mine	Sigma Mines (Québec) Ltd
SLS	solid-liquid separation
SRM	standard reference materials
TSF	Tailing Storage Facility
Tundra	Tundra Gold Mines Inc
VFD	Variable Frequency Drives
VMS	volcanic massive sulfide
YVO	Val-d'Or Regional Airport

# 1 Summary

## 1.1 Introduction

Eldorado Gold Corporation (Eldorado), an international gold and base metal mining company based in Vancouver, British Columbia, owns the Lamaque Complex located in Québec, Canada through its wholly owned subsidiary, Eldorado Gold Québec (EGQ).

The Lamaque Property consists of 76 map designated claims (Exploration Claims (CDC), 1,452 ha), 10 mining concessions (Mining Concessions (CM), 2,325 ha) and one mining lease (Mining Lease (BM), 76 ha), all of which are in good standing at the time of this report.

The Project known as the Lamaque Complex is fully within the Lamaque Property boundaries.

The Lamaque Complex includes the following:

- Triangle mine (upper and lower zones), within the Triangle deposit
- Sigma-Triangle decline (between the Sigma mill and level 0400 of the Triangle mine)
- Future Ormaque mine within the Ormaque deposit
- Parallel deposit (future mining operations)
- Plug No. 4 deposit
- Sigma mill
- Sigma tailings storage facilities (Sigma TSF)
- Infrastructure of the historic Sigma mine (surface pit and underground)
- Mining infrastructure of the historic Lamaque mine (underground)
- Historic Lamaque tailings storage facilities (Lamaque TSF)
- Regional office
- Exploration office and core yard

Eldorado prepared this Technical Report to provide an overall update on the Lamaque Complex. This includes a feasibility-level evaluation assessing the evolution of the current operation based on an update of the Mineral Reserves for the Triangle and Parallel deposits and the addition of the inaugural Mineral Reserves from the Ormaque deposit. The Technical Report also presents a preliminary economic assessment (PEA) including additional Inferred Resources from Triangle and Ormaque in Section 24. This report has been prepared in accordance with Canadian Securities Administrators' National Instrument 43-101 Standards of Disclosure for Mineral Projects ("NI 43-101") and its related 43-101F1.

The Inferred Mineral Resources considered within the PEA in this Technical Report bring to light the favourable extension of the mineralization in concordance with the existing mines. The Inferred Mineral Resources at Triangle and at Ormaque present an opportunity to potentially extend the mine life beyond 2032, as supported by current Mineral Reserves.

Upgrades and continuous improvements to the mining and processing infrastructure have enabled a steady increase in production as stated in the 2018 Technical Report, Lamaque Project (effective date March 21, 2018), referred to as the 2018 PFS and subsequent Technical Report on the Lamaque Project (Effective Date: December 31, 2021) referred to as the 2021 TR. Production has increased from 1,800 tonnes per day (tpd) to current throughput averaging 2,600 tpd. Metallurgical recoveries have achieved an average of 96.8% gold recovery to date, exceeding planned recoveries of 95% in the 2018 PFS.

The Mineral Reserves in the Triangle deposit sit within and to the south of the North Dyke from surface to a depth of approximately 800 m and comprise the mineralized zones C1 through C5 and their associated splays

in the upper mine. The lower zones in the Triangle deposit lies within and to the north of the North Dyke at depths of approximately 700 m to 1,800 m from surface and includes mineralized zones C6 through C10 and their associated splays. The lower Triangle deposit can be accessed from the bottom of the upper Triangle deposit with approximately 600 m of development. The Ormaque deposit is located 200 m east of the Sigma-Triangle decline. The Ormaque deposit is approximately 1.5 km south of the Sigma mill and 1.8 km north of the Triangle deposit. The Parallel deposit is located to the west of Ormaque, approximately 200 m west of the decline.

The PEA presented in Section 24 supporting the Triangle Inferred Mineral Resources and the Ormaque Inferred Mineral Resources considers the potential economic viability of developing the lower zones that comprise the Triangle and Ormaque Inferred Mineral Resources in conjunction with the main zones of the Triangle and Ormaque Mineral Reserves.

Readers should take care to differentiate the PEA from the economic analysis for the Triangle and Ormaque Mineral Reserves. The PEA only demonstrates the potential viability of Inferred Mineral Resources and are not as comprehensive as the economic analysis for the Mineral Reserves. The level of detail, precision, and confidence in outcomes between the economic analysis for Mineral Reserves and the PEA is significantly different.

The PEA is preliminary in nature and is based on numerous assumptions and the incorporation of Inferred Mineral Resources. Inferred Mineral Resources are considered too speculative geologically to have economic considerations applied to them that would enable them to be categorized as Mineral Reserves except as allowed for by National Instrument 43-101 in PEA studies. There is no guarantee that Inferred Mineral Resources can be converted to Indicated or Measured Mineral Resources and, as such, there is no guarantee that the economics described herein will be achieved. Mineral Resources that are not Mineral Reserves do not have demonstrated economic viability.

Geological information and data for this report were obtained from the Lamaque Complex. Metallurgical testwork was completed by third party laboratories to support calculations and optimization of the process flowsheet. The underground mine designs and mining methods, tailings management and water management considered in conjunction with the inferred resources opportunities were designed from first principles to a PEA.

The gold price used in this study is US\$2,000/oz Au for all models. Mineral Reserves contained in the Triangle, Ormaque and Parallel deposits were declared based on a gold price of US\$1,450/oz.

Comparisons of the Lamaque Complex milling production from the 2018 PFS, and 2021 TR Mineral Reserves, actual mine production, and planned 2024 Technical Report Mineral Reserves, show that the Lamaque Complex has exceeded metrics outlined in the original report in terms of both throughput and gold production.

Mill production through the end of 2024 reached 4.75 Mt versus a planned production of 3.51 Mt, reaching over 943 kt milled in 2024, which is 358 kt above the planned production in the 2018 PFS, and 81 kt above the 2021 TR as shown in Figure 1-1.

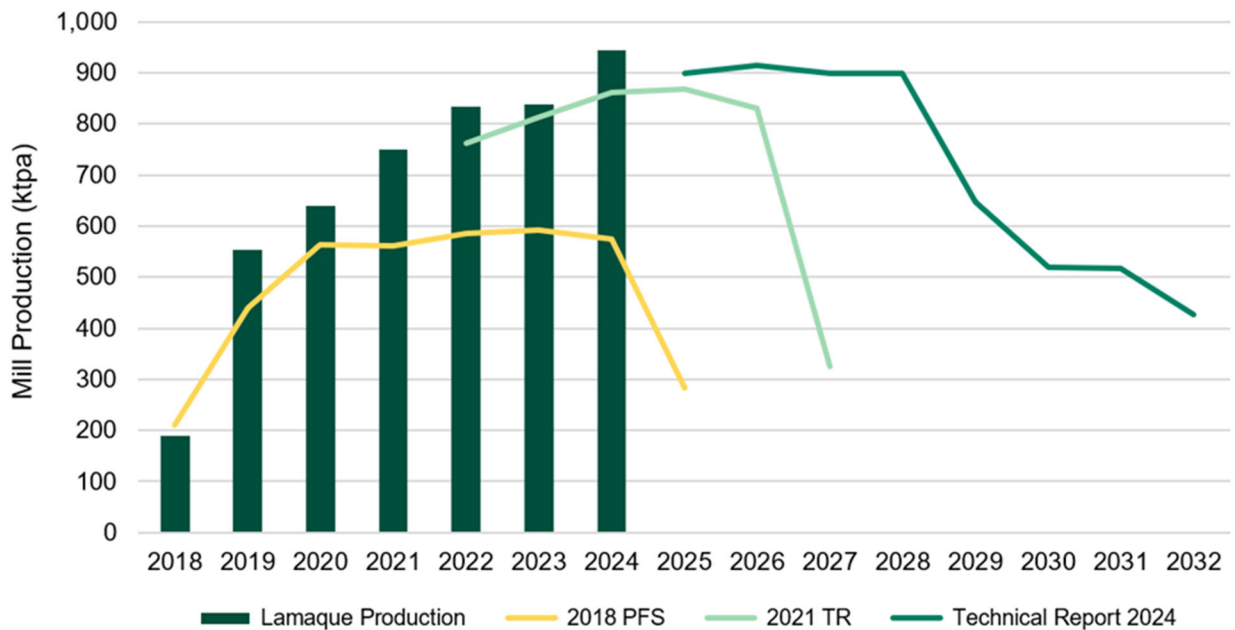

**Figure 1-1: Lamaque Complex Mill Production Comparisons**

Gold production from the Lamaque Complex has also exceeded the metrics set out in the 2018 PFS; gold produced from the Project through the end of 2024 was 991.5 koz Au versus planned production of 884.4 koz Au, with 2024 annual gold production reaching a record 196.5 koz as shown in Figure 1-2.

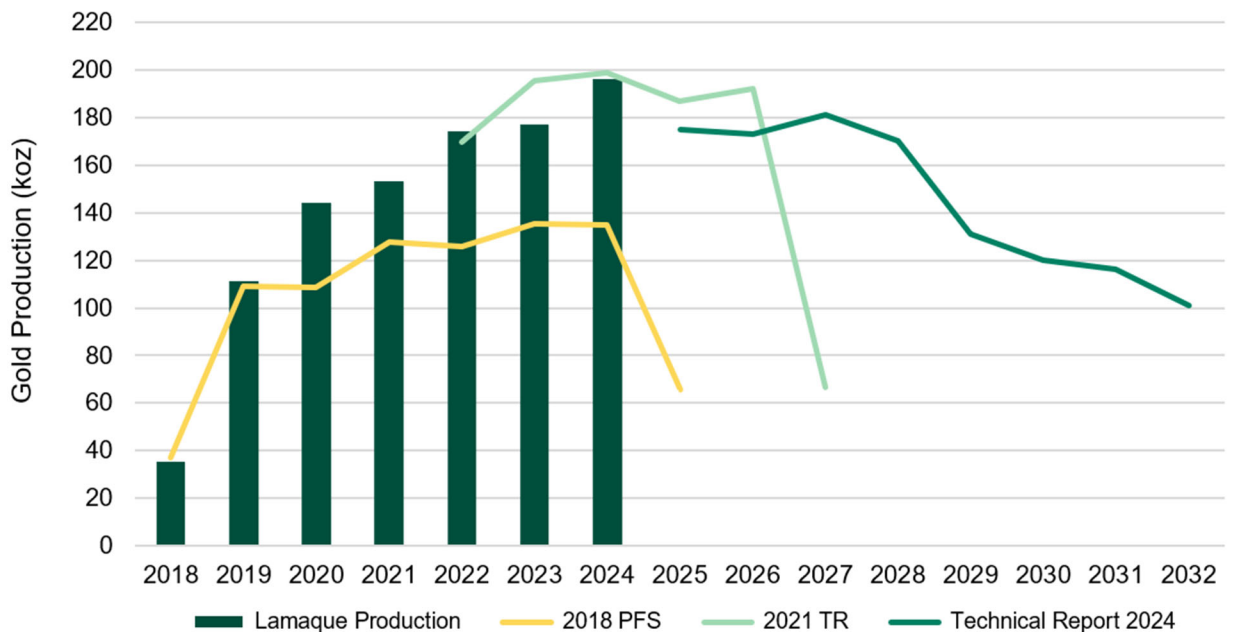

**Figure 1-2: Sigma Mill Gold Production Comparisons**

The current Mineral Reserves of 1,277 koz Au adds over 700 koz Au (after depletion) to the reserves stated in the 2021 TR; adding two years of mine life at the higher throughput.

## 1.2 Contributors and Qualified Persons

The QPs responsible for preparing this Technical Report as defined in NI 43-101, and in compliance with 43-101F1 (the “Technical Report”) are:

- Mr. David Sutherland, P.Eng., Eldorado, author of items 1, 2, 3, 5, 12.2.1, 19, 20, 24.1, 24.2, 24.3, 24.5, 24.12, 24.19, 24.20, 24.24 through 24.26, 25, and 26
- Mr. Jacques Simoneau, P.Geo., Eldorado, author of items 4, 6, 7, 8, 9, 10, 11, 12.2.2, 23, 24.4, 24.6 through 24.11, and 24.23
- Mr. Peter Lind, Eng., P.Eng., Eldorado, author of items 12.2.3, 13, 17, 24.13, and 24.17
- Mr. Jessy Thelland, P.Geo., Eldorado, author of items 12.1, 12.2.4, 14, 15, 16, 21, 22, 24.14, 24.15, 24.16, 24.21, 24.22
- Mr. Philippe Groleau, Eng., Eldorado author of items 12.2.5, 15.3, 16, 18.6, 21, 24.15, and 24.16 specific to the Ormaque deposit.
- Mr. Mehdi Bouanani, Eng., Eldorado author of items 12.2.6, and 18.1 through 18.5, 18.7 through 18.9, 18.13, and 24.18
- Mr. Vu Tran, Eng., Eldorado, author of items 12.2.7, 18.10, 18.11, 18.12, and 24.18.1

## 1.3 Reliance on Other Experts

Eldorado prepared this document with input from the Lamaque Complex staff, other well qualified individuals and experts.

The qualified persons are not experts concerning legal, political, environmental or tax matters relevant to the Technical Report; they have assumed and relied on a report, opinion or statements by information provided by Eldorado.

## 1.4 Property Description and Ownership

The Lamaque Complex is situated immediately east of the city of Val-d’Or in the province of Québec, Canada, approximately 550 km northwest of Montréal. The coordinates for the approximate centre of the Triangle deposit are latitude 48°4’38” N and longitude 77°44’4” W, and for the approximate centre of the Ormaque deposit are latitude 48°5’35” N and longitude 77°44’45” W. According to the Canadian National Topographical System (NTS), the complex is situated on map sheets 32C/04 and 32C/03, between UTM coordinates 295,700 mE and 296,900 mE, and between 5,328,200 mN and 5,329,350 mN (NAD83 projection, Zone 18N). Figure 1-3 shows the Lamaque Property boundaries.

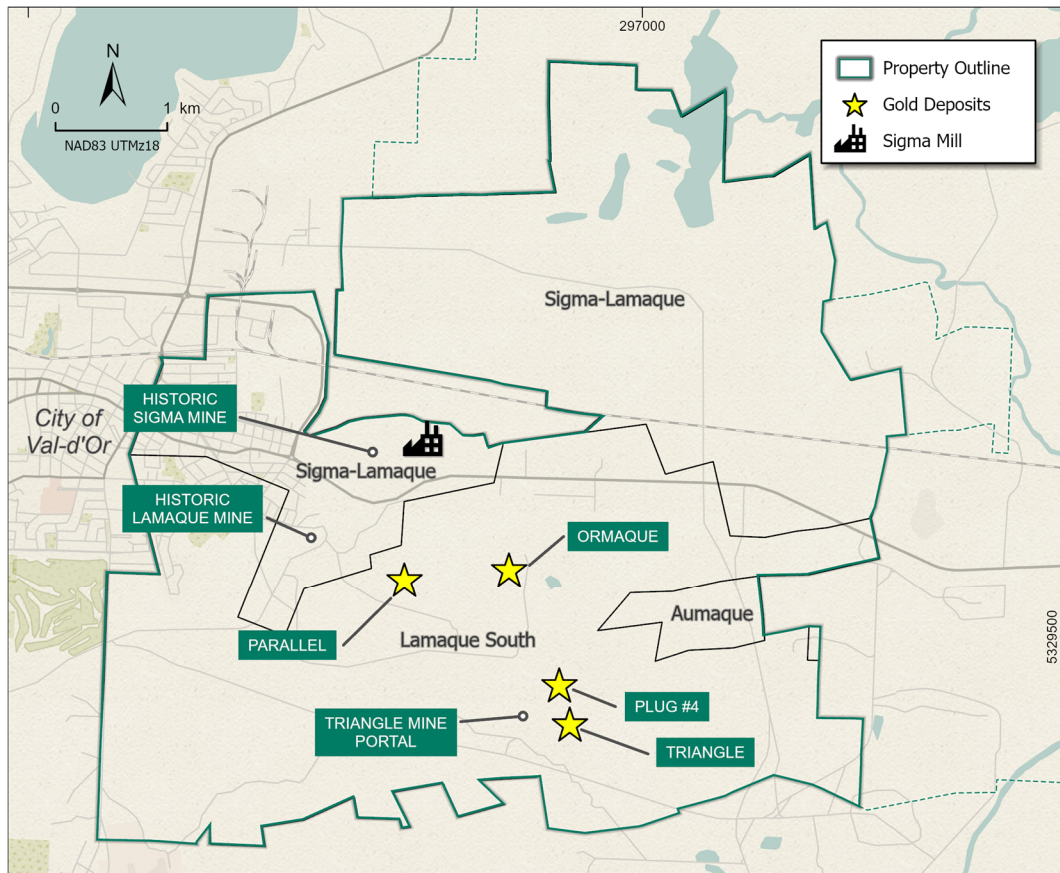

**Figure 1-3: Location of the Lamaque Property with Respect to the City of Val-d'Or (Eldorado 2024)**

The Lamaque Property represent the amalgamation of three separate but contiguous property blocks of designated mining and exploration claims: Lamaque South, Sigma-Lamaque, and Aumaque (Figure 1-4), previously registered to Integra Gold and Or Integra. In 2017, Eldorado acquired all the issued and outstanding shares of Integra Gold and became the sole owner of the Lamaque Complex. In July 2020, Integra Gold and Or Integra were merged into EGQ with all claims, mining concessions and the mining lease forming the Lamaque Complex being registered to EGQ.

The Lamaque Complex (the Project) is located on the Lamaque Property and includes the Triangle mine, Ormaque deposit, Parallel deposit, the Sigma mill, historical Sigma open pit and underground mine, all associated Sigma infrastructure, and the historical Lamaque open pit and underground mine.

The Triangle deposit is currently being mined via surface ramp access. The Sigma-Triangle decline links the 0425 Level of the Triangle mine to the Sigma mill daylighting on the first bench of the historic Sigma pit for mine to mill ore haulage.

The Lamaque Property has been the subject of several agreements in the past involving multiple companies. Although all the claims, mining concessions, and mining leases of the project are 100% owned by EGQ, several of these past agreements included royalties to various companies, a summary of which follows. Figure 1-4 shows the location of where these royalties apply.

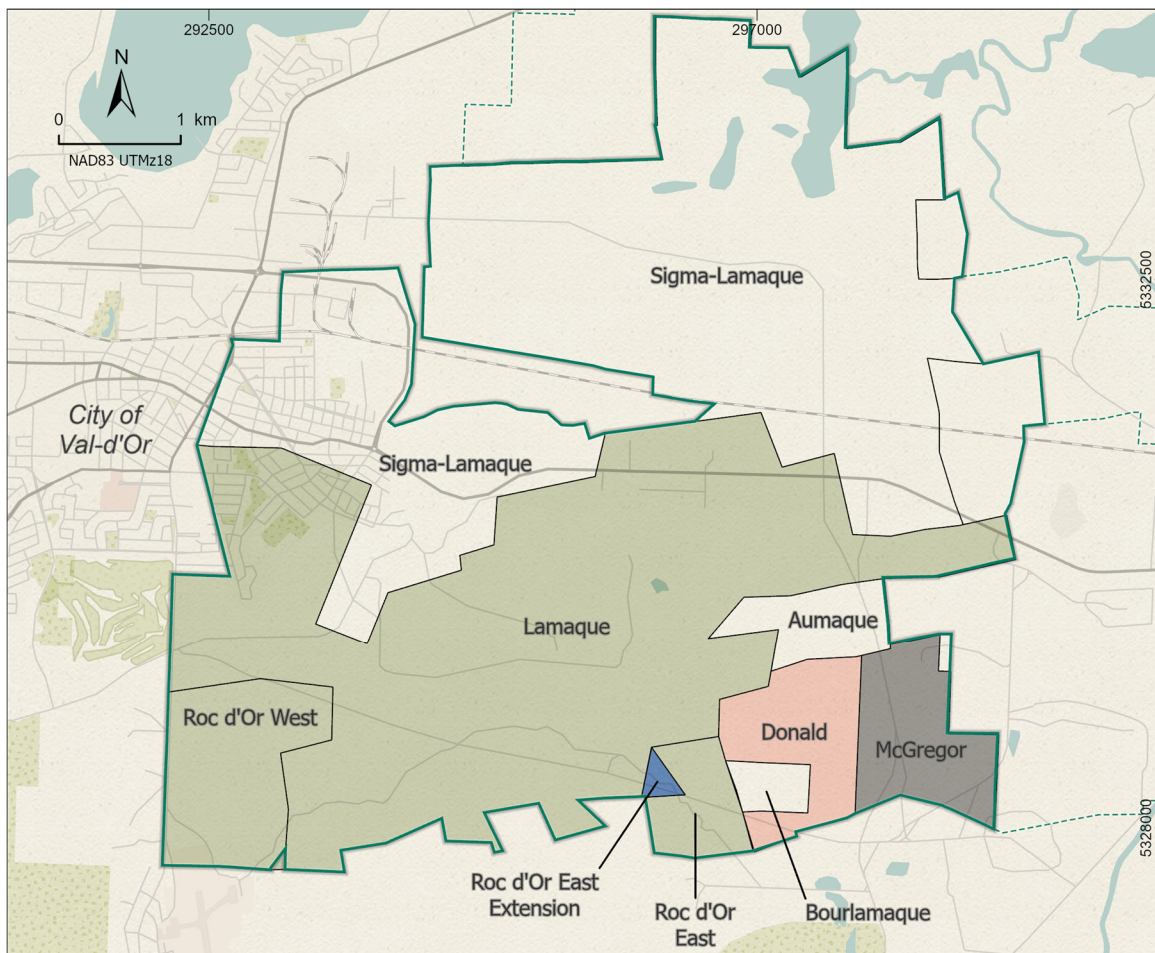

**Figure 1-4: Location of Property in Relation to Royalties (Eldorado 2024)**

The group of claims and mining concessions from the Lamaque, Roc d'Or West, and Roc D'Or East historic properties are currently subject to a 1% NSR royalty to Osisko Royalties. A 2% NSR royalty exists on the small triangle shape claim known as the Roc d'Or East Extension property. This royalty came from a joint venture agreement between Kalahari Resources Inc. and Alexandria. In 2019, Kalahari fulfilled this agreement to earn 100% of the property over a 3-year period leaving the 2% NSR royalty to Alexandria which was purchased by Sandstorm in 2015. In 2020, Eldorado exercised the buyback of the 1% royalty on the Roc d'Or East Extension royalty owned by Sandstorm.

In December 2010, Integra acquired an option to earn a 100% interest in the historic Bourlamaque Property (2 claims; 16 hectares) in Bourlamaque Township, adjacent to the Lamaque Project. In addition to fulfilling the terms of the agreement, Integra also purchased the entire NSR royalty for CAD\$5,000 on 30 April 2013.

In June 2011, Integra entered into an option agreement to acquire a 100% interest in the McGregor Property which is subject to a 2% NSR royalty, 0.6% of which is payable to Jean Robert, 0.6% to Les Explorations Carat and the remaining 0.8% to Albert Audet. One-half (1%) of this NSR royalty may be purchased for CAD\$500,000.

In January 2012, Integra entered into an option agreement to acquire a 100% interest in the Donald Property which is subject to a 3% gross metal royalty payable to Les Entreprises Minière Globex Inc., one-third (1%) of which may be purchased for CAD\$750,000.

## 1.5 Accessibility, Climate, Local Resources, Infrastructure and Physiography

The Sigma mill is accessed via the Provincial Highway 117, 1.4 km east of Val-d'Or. The Triangle mine site is accessed from the south of Val-d'Or, 3.7 km east along a private gravel service road, Voie de Service Goldex-Manitou. Roads are well maintained with year around access to the all the infrastructure of the Lamaque Complex.

The city of Val-d'Or has a humid continental climate that closely borders on a subarctic climate. Winters are cold and snowy, and summers are warm and damp. All requirements, including a sufficient hydro-electric power from the grid, and services from Val-d'Or, are available to support a mining operation. There is an ample supply of water at the Lamaque Complex to supply mining and milling operations. Also available locally is a skilled labor force with experienced mining and technical personnel.

The Abitibi region has a typical Canadian Shield type terrain characterized by low local relief with occasional hills and abundant lakes. The mine site is bordered to the north by a large unpopulated wooded area, a portion of which is currently used for tailings and waste rock disposal.

## 1.6 History

Val-d'Or has been a highly active mining area for a century, with significant mineral deposits present throughout the region. Gold has been produced from the historic Sigma and Lamaque mines starting in the early 1930's. More recently, Eldorado acquired the Lamaque Complex through the purchase of Integra Gold Corp in 2017. Eldorado has been operating uninterruptedly since start of its commercial production on March 31, 2019, from ore mined at the Triangle deposit and processed at the refurbished Sigma mill.

## 1.7 Geology and Mineralization

The Lamaque Project is located in the southeastern Abitibi Greenstone Belt of the Archean Superior Province in the Canadian Shield. The Abitibi Greenstone Belt, as shown in Figure 1-5, comprises dominantly east-trending folded volcanic and metasedimentary rocks and intervening domes cored by plutonic rocks. Submarine mafic volcanic rocks dominate forming approximately 90% of the area. The Abitibi Greenstone Belt is intruded by numerous syn to late tectonic plutons composed mainly of syenite, gabbro, diorite, and granite with lesser lamprophyre and carbonatite dykes.

Regional stratigraphic correlation between the volcanic and sedimentary rocks is hampered by the fact that boundaries between lithostratigraphic units are commonly structural in nature and glacial cover is extensive in some areas. The Val-d'Or region is dominated by stratigraphic groups and formations that occur mostly within the Tisdale and Blake River assemblages.

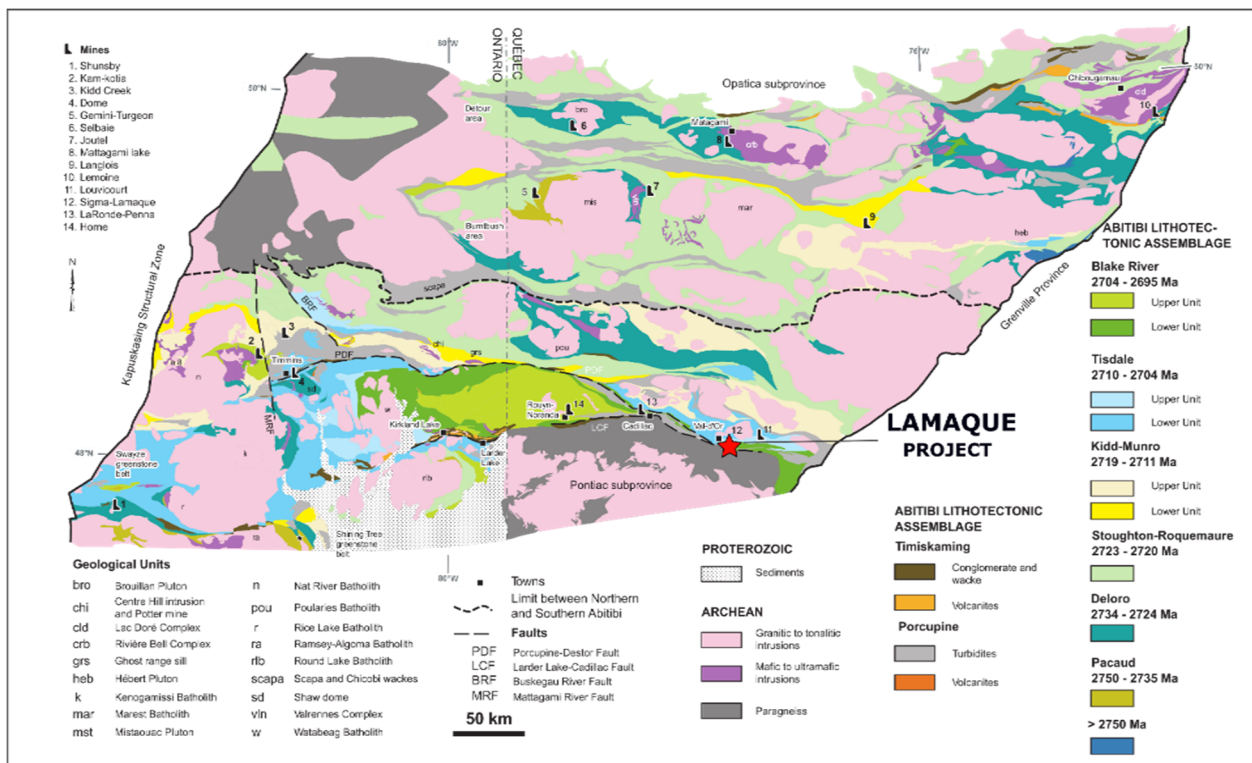

**Figure 1-5: Geology of the Abitibi Greenstone Belt**

The Larder Lake-Cadillac Fault Zone (LLCFZ) is the major fault in the region and defines the contact between the southward-facing volcanic successions of the Malartic Group and the younger folded, but dominantly northward-facing, graywacke-mudstone successions of the Pontiac Group to the south.

Most of the gold in the Lamaque Complex area is hosted by quartz-tourmaline-carbonate veins, which vary from shear hosted and/or extensional vein systems to complex stockworks zones.

The Triangle gold deposit was discovered in 2011 by drilling an isolated circular magnetic high anomaly in the south part of the project area. The volcanoclastic rocks in the Triangle deposit consist of feldspar phenocryst rich (fragments and matrix) lapilli-block tuffs of andesitic to basalt composition. The texture of the coarse-grained matrix is generally massive; however, grading can be observed locally. Fine grained beds are less common and turbidite facies have not been observed. Rare thin concordant lava flows, as well as complex and irregular subvolcanic intrusions, are intercalated within the volcanoclastic sequence. The tuffs lack penetrative schistosity but contain a stretching lineation and a weak flattening and alignment of fragments. The strong competency of the rocks surrounding the Triangle Plug coincides with a mineralogical change from Fe-Mg chlorite and paragonitic muscovite in the volcanic rocks to a Mg-dominant chlorite and muscovite with pervasive albite-quartz-epidote (magnetite-pyrite) in and around the plug.

The Triangle Plug is a chimney-shaped feldspar porphyritic diorite very similar in composition to the Main Plug at the Lamaque deposit. The Triangle Plug is composed of two different facies of the porphyritic diorite: a mafic facies composed of 25-40% hornblende pseudomorphs (now chlorite-altered) with minor chloritized biotite in the matrix, and a more felsic facies with less than 25% mafic minerals in the matrix. For both facies, the rock contains 10-30% medium-grained zoned feldspar phenocrysts. The Triangle Plug plunges at roughly 70° towards the NNE. At a depth of around 700 m below surface, the Triangle Plug cuts a large dyke called the North Dyke, which extends east-west for over 4 km and dips vertically. The North Dyke is also a feldspar

porphyritic diorite that shares similarities to both facies of the Triangle Plug. The dyke has been traced to a depth of over 1,800 m below surface.

Gold mineralization in the Triangle deposit occurs primarily within quartz-tourmaline-carbonate-pyrite veins in the Triangle Plug and adjacent massive mafic lapilli-blocks tuffs.

Gold mineralization at the Parallel deposit is hosted within shear and extension veins hosted by the fine- to medium-grained C-porphyry diorite.

The Ormaque deposit is located immediately east of the Parallel deposit. The Ormaque vein system occurs within the C-porphyry at the contact with volcanoclastic rocks to the north. Gold mineralization occurs dominantly in gently south-dipping quartz-tourmaline-carbonate extension veins and localized breccia zones.

## 1.8 Deposit Types

The gold deposits in the Val-d'Or area are consistent with the orogenic gold model. Orogenic gold deposits are typically distributed along first-order compressional to transpressional crustal-scale fault zones that mark the convergent margins between major lithological and/or tectonic boundaries such as the Larder Lake–Cadillac Fault Zone.

Most orogenic gold deposits in Archean terranes are hosted in greenstone belts. In the Lamaque Project area, competency contrasts are the most important localizing host rock control. At Lamaque and Triangle the intersection of shear zones with late diorite to granodiorite plugs host the main gold-bearing veins, whereas at Sigma and Ormaque a syn-volcanic diorite (the C-porphyry) hosts mineralization near the sheared contact with the surrounding volcanoclastic rocks.

Orogenic gold deposits develop in response to shear failure, extensional failure and/or hybrid extensional shear failure. In the Lamaque Project area both shear veins and extension veins are widely recognized, and their identification is important to constrain vein geometries and ore shoots. In the Triangle deposits the main C vein structures are steeply dipping shear veins and host the bulk of the resource, whereas in the Ormaque deposit gently dipping extension veins contain most of the ore.

## 1.9 Exploration

Exploration in the Val-d'Or area has been on-going for nearly a century. Since the acquisition of Integra Gold Corp. by Eldorado in 2017, significant exploration activities occurred at Triangle as well as several other targets including Plug No. 4, Parallel, Aumaque, South Gabbro, Lamaque Deep, Vein No. 6, P5 Gap, Sigma East Extension, Sector Nord, amongst others. In January 2020, Eldorado announced the discovery of the Ormaque deposit. Eldorado continues to explore the Sigma-Lamaque property extensively.

## 1.10 Drilling, Sampling Method, Approach and Analyses

Drilling on the Triangle, Plug No. 4, Parallel, and Ormaque deposits amount to 6,631 completed drill holes totaling some 1,435,381 m summarized by deposit in Table 1-1. The bulk of the drilling has been completed since 2015 when Eldorado took over the responsibilities for planning, core logging, interpretation and supervision and data validation of the diamond drill campaigns.

**Table 1-1: Summary of Drilling on the Sigma-Lamaque Block Deposits**

Deposit	No. Completed Holes	No. Surface Holes	No. Underground Holes	Meters
Triangle Deposit	5,505	922	4,583	1,063,451
Plug No. 4 Deposit	112	94	18	62,203
Parallel Deposit	253	237	16	69,912
Ormaque Deposit	761	288	473	239,815
<b>TOTAL</b>	<b>6,631</b>	<b>1,541</b>	<b>5,090</b>	<b>1,435,381</b>

Drilling is done by wireline method with NQ sized core (47.6 mm nominal core diameter) or BQTK sized core (40.7 mm nominal core diameter). Geology and geotechnical data are collected from the core before sampling. All vein and shear zone occurrences are sampled with additional “bracket sampling” into unmineralized host rock on both sides of the veins or shear zones. Typically, about 50% of a hole is sampled. The core is cut at Eldorado’s core facility in Val-d’Or, Québec. For security and quality control, diamond drill core samples are catalogued on sample shipment memos, which are completed at the time the samples are being packed for shipment. Standards, duplicates, and blanks are inserted into the sample stream by Eldorado staff.

### 1.11 Sample Preparation, Analyses and Security

Sample preparation procedures including an initial crush to 10 mesh followed by a riffle split of a 250 g subsample which was pulverized to 85% passing 200 mesh. This subsample is sent for assay where a 30 g subsample is taken and fire-assayed with an atomic absorption (AA) spectrometry finish. During an exploration campaign any values greater than or equal to 5 g/t Au are reassayed by fire assay using a gravimetric finish. For resources conversion and infill drilling campaign, the gravimetric re-assay threshold is increased to 10.0 g/t. The sample batches contained QA/QC samples comprising standard reference materials (SRMs), duplicates and blanks.

It is the QPs opinion that the QA/QC results demonstrate that the assays contained in the database are sufficiently accurate and precise for resource estimation.

### 1.12 Data Verification

Checks to the entire drillhole database were undertaken and comparisons made between the digital database and original assay certificates. Eldorado concluded that the data supporting the Lamaque Project resource work is sufficiently free of error to be adequate for estimation.

The qualified persons have all completed data verification for their respective sections, as described in Section 12.

### 1.13 Metallurgical Testing

The metallurgical responses of ores from upper Triangle are well understood given six years of operating data and extensive metallurgical testwork that has been completed. Tests included chemical analyses, comminution test work, gravity concentration tests, whole ore cyanidation tests, carbon gold loading tests, cyanide destruction tests as well as thickening, rheology, and filtration test work. High metallurgical

recoveries (97%) are obtained with the upper Triangle ores and require a fine grind size (40 – 60 µm P<sub>80</sub>), long retention time (>70 hours), and high pH.

Recent testwork programs have focused on samples from lower Triangle zones (C6 through C10) and the Ormaque deposit. Testwork programs have been carried out by third-party commercial laboratories.

Compared to ore from Upper Triangle zones (C1 to C5), the Lower Triangle samples are slightly harder with a Bond Ball Mill work index of 12.8 kWh/t to 13.5 kWh/t. Recoveries from Lower Triangle are slightly lower than Upper Triangle, with an overall average recovery of 97% for Triangle. Overall, material from the C5 zone is harder than material from Ormaque as well as from the other zones in Upper and lower Triangle.

Samples tested from Ormaque indicate that the mineralized material is somewhat harder at 14.2 kWh/t and with metallurgical recoveries in line with upper Triangle (97%) ores. A higher proportion of coarse gravity-recoverable gold was noted with the Ormaque samples, which was also observed during the recent processing of the Ormaque bulk sample.

The bulk sample of Ormaque ore was excavated during Q3 and Q4 and has been processed at the Sigma mill in December. A total of 36,358 tonnes was mined at a sampled grade of 14.93g/t. Between December 2<sup>nd</sup> and December 12<sup>th</sup>, 28,405 tonnes were processed at the Sigma mill exclusively from the Ormaque deposit. The head grade was 15.3 g/t, producing 13,652 oz of gold with a recovery rate of 98%. Remaining bulk sampled material was processed in a blend with Triangle run-of-mine ore. The estimated grade from the resource model for the corresponding blocks that were mined was 10.1 g/t.

Recoveries from the Parallel deposit were assumed to be slightly lower, at 95%.

## 1.14 Mineral Resource Estimate

### 1.14.1 Triangle Deposit

The Mineral Resource estimate for the Triangle deposit used data from both surface and underground diamond drillholes. The resource estimates were made from 3D block models created by utilizing the Seequent and Deswik suite of geological modelling and mine planning software. The parent block model cell size is 5 m east by 5 m north by 5 m high and is then sub-blocked to 1 m east by 1 m north with a variable height between 0.1 to 1 m.

The Mineral Resources of the Triangle deposit were classified using logic consistent with the CIM Definition Standards for Mineral Resources and Mineral Reserves referred to in NI 43-101. The mineralization of the project satisfies sufficient criteria to be classified into Measured, Indicated, and Inferred Mineral Resource categories.

The Mineral Resources for the Triangle deposit, as of September 30, 2024, are shown in Table 1-2. The resources do not include 23 kt in surface stockpiles as of the end of September 2024. The Mineral Resources are reported within the constraining mineralized domain volumes that were created to control resource reporting and are based on a 3.0 g/t gold cut-off grade.

**Table 1-2: Triangle Mineral Resources, as of September 30, 2024**

Deposit Name	Categories	Tonnes (x 1,000)	Grade Au (g/t)	Contained Au (oz x 1,000)
Triangle Resources	Measured	2,268	6.53	476
	Indicated	3,436	6.62	731
	<b>Measured + Indicated</b>	<b>5,704</b>	<b>6.58</b>	<b>1,207</b>
	<b>Inferred</b>	<b>7,508</b>	<b>6.52</b>	<b>1,574</b>

### 1.14.2 Parallel Deposit

The Mineral Resource estimate for the Parallel deposit used data from surface diamond drillholes. The resource estimates were made from 3D block models created by utilizing commercial geological modelling and mine planning software. The block model cell size is 5 m east by 5 m north by 5 m high. The block model was not rotated.

The Mineral Resources of the Parallel deposit were classified using logic consistent with the CIM Definition Standards for Mineral Resources and Mineral Reserves referred to in NI 43-101. The mineralization of the project satisfies sufficient criteria to be classified into Indicated and Inferred Mineral Resource categories. Mineral Resources that are not Mineral Reserves have no demonstrated economic viability.

The Mineral Resources for the Parallel deposit, as of September 30, 2024, are shown in Table 1-3. The Mineral Resources are reported within the constraining domain volumes that were created to control resource reporting and at a 3.0 g/t gold cut-off grade.

**Table 1-3: Parallel Mineral Resources, as of September 30, 2024**

Deposit Name	Categories	Tonnes (× 1,000)	Grade Au (g/t)	Contained Au (oz × 1,000)
Parallel	Indicated	221	9.87	70.2
	Inferred	200	8.83	56.7

Due to its similarity with the Triangle deposit, the same classification approach is used in the Parallel deposit, where the average distance of the samples to a block center interpolated by samples from at least two drill holes, up to 30 m was classified as Indicated Mineral Resources. All remaining model blocks containing a gold grade estimate were assigned as Inferred Mineral Resources.

### 1.14.3 Plug No. 4 Deposit

The Mineral Resources of the Plug No. 4 zone were classified using logic consistent with the CIM Definition Standards for Mineral Resources and Mineral Reserves referred to in NI 43-101. Mineral Resource Summary.

The Mineral Resources for Plug No. 4, as of September 30, 2024, are shown in Table 1-4. The Mineral Resources are reported within the constraining volumes that were created to control resource reporting at a 3.5 g/t gold cut-off grade.

**Table 1-4: Plug No. 4 Mineral Resources, as of September 30, 2024**

Deposit Name	Categories	Tonnes (× 1,000)	Grade Au (g/t)	Contained Au (oz × 1,000)
Plug No. 4	Indicated	709	6.39	146
	Inferred	481	6.67	103

### 1.14.4 Ormaque Deposit

The Mineral Resource estimate for the Ormaque deposit used data from both surface and underground diamond drillholes. The resource estimates were made from 3D block models created by utilizing Seequent and Deswik suite of geological modelling and mine planning software.

The parent block model cell size is 5 m east by 5 m north by 5 m high and is then sub-blocked to 1 m east by 1 m north and a variable height between 0.1 to 1 m.

The Mineral Resources of the Ormaque deposit were classified using logic consistent with the CIM Definition Standards for Mineral Resources and Mineral Reserves referred to in NI 43-101.

The Mineral Resources for the Ormaque deposit, as of September 30, 2024, are shown in Table 1-5. The Mineral Resources are reported within the constraining volumes that were created to control resource reporting at a 3.5 g/t gold cut-off grade.

**Table 1-5: Ormaque Mineral Resources, as of September 30, 2024**

Deposit Name	Categories	Tonnes (x 1,000)	Grade Au (g/t)	Contained Au (oz x 1,000)
Ormaque	Measured	3	7.76	1
	Indicated	1,414	16.44	747
	<b>Measured + Indicated</b>	<b>1,417</b>	<b>16.42</b>	<b>748</b>
	<b>Inferred</b>	<b>1,749</b>	<b>14.87</b>	<b>837</b>

## 1.15 Mineral Reserve Estimates

The Mineral Reserve estimate is based on Measured and Indicated Mineral Resources for the Triangle deposit, the Parallel deposit and the Ormaque deposit, upon which the mining plan and economical study have demonstrated economical extraction. Mineral Reserves are reported using a gold price of \$1,450 per ounce and an exchange rate of 1.30 CAD\$/US\$. Two cut-off grades were determined depending on the mining method used:

- 4.99 g/t for the long hole method used for Triangle and Parallel deposits
- 5.67 g/t for the drift and fill method used for Ormaque deposit

Areas of uncertainty that may materially impact the Mineral Reserve estimates include and are not restricted to:

- Gold market price and exchange rate
- Costs assumptions, in particular cost escalation
- Geological complexity and continuity
- Dilution and recovery factors
- Geotechnical assumptions concerning rock mass stability

Using Deswik Stope Optimizer Module, stope shapes were created using the following constraints and modifying factors:

- Long Hole Mining (Triangle and Parallel deposits)
  - Sizing
    - Vertical Height: 25 m
    - Minimum dip 45°
    - Between 3 m and 7 m thickness → Longitudinal Retreat
    - More than 7 m thickness with sufficient continuity → Transverse Primary / Secondary
  - External dilution of 25%
  - Mining recovery of 95%
  - Ore development included in Mineral Reserves considered 100% mining recovery and no overbreak dilution
  - Ore development below breakeven cut-off grade but higher than 3.0 g/t was included as Mineral Reserves material if development was mandatory

- Metallurgical recovery of 97%
- Drift-and-Fill Mining (Ormaque deposit)
  - Sizing
    - Drift Profile of 5 m wide by 3 m high, no maximum length
    - +15% to -15% drift gradient
  - External dilution of 13%
  - Mining recovery of 98%
  - Ore development included in Mineral Reserves considered 100% mining recovery and no overbreak dilution
  - Ore development below breakeven cut-off grade but higher than 4.0 g/t was included as Mineral Reserves material if development was mandatory
  - Metallurgical recovery of 97%

Mineral Reserves for the Triangle, Ormaque and Parallel deposits were prepared by EGQ Technical Services staff. The Mineral Reserve estimate is summarized in Table 1-6 and has an effective date of September 30, 2024. All Mineral Reserves are classified as Proven or Probable in accordance with the 2019 CIM Estimation of Mineral Resources and Mineral Reserves Best Practices Guidelines.

As a matter of clarification, the identified Mineral Reserves are included in the total Mineral Resources described in Section 14. Tonnes and grade are diluted and considering mining recovery.

**Table 1-6: Lamaque Complex Mineral Reserves as of September 30, 2024**

Deposits	Proven			Probable			Total P&P		
	Tonnes	Grade	Ounces	Tonnes	Grade	Ounces	Tonnes	Grade	Ounces
Triangle	1,356,672	5.70	248,815	1,681,984	6.58	355,953	3,038,656	6.19	604,768
Ormaque	3 257	7.76	813	2,661,130	7.22	617,791	2,664,387	7.22	618,603
Parallel	-	-	-	274,150	6.04	53,227	274,150	6.04	53,227
<b>Total</b>	<b>1,359,929</b>	<b>5.71</b>	<b>249,628</b>	<b>4,617,264</b>	<b>6.92</b>	<b>1,026,971</b>	<b>5,973,936</b>	<b>6.65</b>	<b>1,276,598</b>

During the 4<sup>th</sup> quarter of 2024, the Lamaque Complex produced 63,742 ounces of gold, out of which 16,757 ounces came from the Ormaque deposit during the processing of the bulk sample in December, as expressed in Table 1-7.

**Table 1-7: Lamaque Complex Mineral Gold Production during Q4 2024**

	Tonnes Processed	Head Grade	Ounces Produced
Triangle	220,270	6.91	46,985
Ormaque	36,358	14.93	16,757
<b>Total Processed Sigma mill</b>	<b>256,628</b>	<b>8.05</b>	<b>63,742</b>

## 1.16 Mining Methods

The primary mining method that is currently used at the Triangle deposit is mechanized longhole stoping. The existing mobile equipment fleet of conventional equipment, mine infrastructure, and services, as well as workforce skillsets are based on longhole, and this method will continue to be used. Ore is transferred to

surface using 45-tonne rated underground haulage trucks via the Sigma-Triangle decline to the surface ore pad near the Sigma mill facility.

The current longhole stoping mining method will be maintained in the proposed mining of the lower Triangle deposit.

In the proposed mining of the Ormaque deposit, drift and fill (DAF) mining methods will be employed due to the shallow-dipping orientation of the mineralized zones, allowing for near-complete recovery of mineralization and providing better selectivity while allowing low grade material to be left in the stopes. Some specifically adapted equipment is required to achieve the design height in Ormaque.

The mine operation is currently using cemented rockfill (CRF) and unconsolidated rockfill as backfill. In the proposed Triangle and Ormaque mine plans, addition of a paste fill plant is included to provide cemented paste fill. Mineralized material will continue to be transferred to surface using 45-tonne rated underground haulage trucks. Where practical, waste rock will remain underground for use as backfill.

## 1.17 Process Plant and Recovery Methods

The annual throughput rate is anticipated to reach as high as 965 ktpa. This corresponds to a plant throughput of 115 tonnes per operating hour which has been achievable recently. Minor debottlenecking improvements are planned to ensure that the mill throughput capacity and availability keep pace with the mining production rate.

The Sigma mill operates a conventional process including crushing, grinding, gravity concentration, leach, and carbon-in-pulp (CIP) circuits, as well as elution, carbon regeneration and refinery areas. Metallurgical recoveries through the Sigma mill averaged 96.2% over the last twelve months. Expected recoveries for Triangle are 97%, Ormaque expected recoveries are 97%, and expected recoveries for Parallel are 95%. Recoveries have been slightly higher during the summer period due to the positive benefit of higher leach temperatures.

## 1.18 Infrastructure

The site attained commercial production on March 31, 2019. The region is in an active mining jurisdiction with the Project in close proximity Val d'Or where there is existing infrastructure and resources required to support continued operations.

The following infrastructure exists at the respective areas of the overall site:

- Triangle mine
  - mine dry and office
  - garage
  - warehouse
  - mine ventilation facilities
  - compressor house
  - waste rock stockpile
  - slurry plant
  - cement silo
  - core logging building
  - surface fuel station
- Sigma mill
  - main plant

- covered crushed ore storage
  - crushing facility
  - warehouse
- Support infrastructure
  - regional administration office
  - exploration office and core yard
  - construction offices near Sigma mill
- Site water management and collection ponds
- Sigma tailings storage facility (TSF)
- Triangle waste rock dump

### 1.18.1 Required Infrastructure

New infrastructure is planned to support the development of the Project.

A paste plant will be constructed with piping connected to the Sigma mill for the supply of tailings. Bore holes and reticulation piping for cemented paste supply to the future Ormaque mine, and Triangle mine will be provided via the Sigma-Triangle decline.

Construction of the North Basin is planned north of the Sigma TSF to reduce water storage on the facility, increasing tailings capacity. A future lift is also planned to further increase capacity.

A waste rock dump is planned for storage of waste rock from Ormaque mining activities located east of the Sigma TSF.

## 1.19 Market Studies and Contracts

Eldorado currently sells gold doré from the Lamaque Project, which is sold to certified refineries in Ontario and Québec. Existing contracts for consumables and services are within industry norms. There are no material contracts required for the development of the Project.

## 1.20 Environment and Permitting

The Lamaque Complex is operating and is fully permitted under Federal and Provincial regulations. The Lamaque Complex operates in compliance with environmental quality standards and is regularly assessed by Provincial authorities regarding the Environment Quality Act (EQA) of Québec. Changes to the existing permits including planned lifts to the Sigma tailings management facilities phase IV lift have been discussed with the Provincial Ministries and there are no indications that the Project will not be successful in obtaining permit amendments similar to the previous phases of the Project.

Triangle is fully permitted under existing certificates of authorizations (CoA).

There is an existing CoA for mining in the Ormaque deposit, but this will require an amendment to the CoA to allow for mining below a depth of 453 m; there are no indications of any significant challenges in obtaining a permit amendment.

Reclamation costs for the Lamaque Complex were evaluated at US\$11.84 M based on recent cost assessments completed in 2024.

EGQ is actively engaged in stakeholder engagement. In May 2015, a Monitoring Committee was formed to keep the Company's stakeholders informed about the Lamaque Project. Quarterly meetings are organized to provide updates on the status of the Project to the committee members. All proceedings are put on the

Company's website. The purpose of such a monitoring committee, which is required under section 101.0.3 of the Québec Mining Act, is to develop the involvement of the local community in mining projects. The committee has representatives from the municipal sector, the economic sector, the public and the Nation Anishnabe de Lac Simon.

## 1.21 Capital and Operating Costs

### 1.21.1 Capital Costs

The capital cost estimate required for mining and processing the Triangle, Ormaque, and Parallel Mineral Reserves is effective Q4 2024 and expressed in constant dollars. The total capital costs consist of US\$226.5 M in growth capital and US\$270.3 M in sustaining capital, as summarized in Table 1-8.

Significant growth capital items include development mining to access the Ormaque deposit, construction of a paste plant and reticulation system, addition of North Basin and additional tailings lift on the Sigma TSF, historic Lamaque TSF stability program, and the exploration drilling program

Significant sustaining capital costs include sustaining mine development at Triangle, Ormaque, and Parallel, general and administrative overhead costs supporting mine development, exploration and delineation drilling programs, closure costs, and a credited salvage value at the end of the mine life.

**Table 1-8: Capital Cost Estimate**

Description	Growth (\$M)	Sustaining (\$M)	Total (\$M)
Mining	100.8	200.9	301.7
Processing	96.4	11.8	108.2
General and Administration	1.3	44.1	45.3
Infrastructure	0.0	0.0	0.0
Exploration and Delineation Drilling	28.0	4.7	32.8
Closure	0.0	11.8	11.8
Salvage (credit)	0.0	(3.0)	(3.0)
<b>Total</b>	<b>226.5</b>	<b>270.3</b>	<b>496.8</b>

### 1.21.2 Operating Costs

The average operating cost for mining and processing the Mineral Reserves over the mine life is estimated to be US\$189.02/t of ore or US\$922.25/oz Au. Table 1-9 provides the breakdown of the projected operating costs for the Mineral Reserve.

**Table 1-9: Operating Cost Summary**

Cost Area	Annual average cost (\$M)	Average cost (\$/tonne ore)	Average cost (\$/oz Au)
Underground Mining	96.7	136.00	662.46
Processing	19.0	26.50	129.83
General and Administration	19.0	26.52	129.96
<b>Total</b>	<b>134.6</b>	<b>189.02</b>	<b>922.25</b>

## 1.22 Financial Analysis

The economic analysis for the Triangle, Ormaque, and Parallel Mineral Reserves, based on US\$2,000/oz Au, indicates an after-tax net present value (NPV) of US\$555.0M, using a discount rate of 5% utilizing mid-year discounting convention.

The economic models were subjected to sensitivity analyses to determine the effects of changing metal prices, capital, and operating expenditures on financial returns. This analysis showed that the Project economics are robust and are most sensitive to metal prices.

## 1.23 Adjacent Properties

None of the adjacent properties are relevant or material to the disclosure in this Technical Report.

## 1.24 Other Relevant Data and Information Opportunities

### 1.24.1 PEA Summary

This Technical Report describes the results of a Preliminary Economic Assessment (PEA) that incorporates additional Mineral Resources from the Triangle and future Ormaque mines in Section 24. These Mineral Resources are primarily Inferred Mineral Resources located at depth and within lateral extensions of shallower zones that have not been converted to Mineral Reserves as described in the other sections of this Technical Report.

### 1.24.2 PEA Introduction

The PEA highlights the additional value and potential for extended mine life with the inclusion of Mineral Resources from lower Triangle and deeper in the Ormaque deposit.

The assessment and economic analysis to be presented is only for the mining and processing of mineralized material contained in the Mineral Resources not included in the Mineral Reserves.

### 1.24.3 PEA Mineral Processing and Metallurgical Testing

Testwork has been conducted for both the lower zones of the Triangle and Ormaque deposits. Hardness in both zones tend to be slightly harder with lower Triangle having an average Bond Ball Mill Work Index of 16.0 kWh/t and Ormaque having an average 15.3 kWh/t. No challenges are foreseen for processing of material through the Sigma mill.

### 1.24.4 PEA Inferred Mineral Resources

The Mineral Resource Estimate for the overall Lamaque Complex is presented in Section 14 of this Technical Report. For the purposes of the PEA, a subset of the total resource, including Inferred material, has been considered. In order to generate a consolidated optimized mine plan, in addition of the Measured and Indicated Mineral Resources from Triangle, Ormaque and Parallel, the Inferred Mineral Resources from the Triangle and Ormaque deposit were considered for subsequent steps.

The Mineral Resource models were prepared by Eldorado and have an effective date of September 30, 2024. Using the Mineral Resources described in section 24.14, the same modifying factor and cut-off grades described in Section 15 were applied in order to quantify the amenable mineralized material to mining. A summary of the incremental mineralized material that is amenable to mining and considered in the PEA is found in Table 1-10.

**Table 1-10: Summary of Incremental Mineralized Material compared to Mineral Reserves**

Mine	Tonnes (× 1000)	Grade Au (g/t)	Contained Au (oz × 1000)
Triangle	4,132	6.11	812
Ormaque	2,962	8.17	778
<b>Total</b>	<b>7,093</b>	<b>7.20</b>	<b>1,642</b>

### 1.24.5 Mineral Reserve Estimates

No Mineral Reserves are included within the PEA described in Section 24.

### 1.24.6 PEA Mining Methods

Conventional mining methods as previously described are considered within the PEA.

The PEA presents the potential for mining and processing Inferred Mineral Resources (mineralized material) mostly at depth in the Triangle and Ormaque deposits.

Production rates for longhole mining are based on historic performance at Triangle. Due to increased travel times to access deeper zones stope mucking rates have been adjusted for zones C6 to C8 and C9 to C11 as shown in Table 1-11.

**Table 1-11: Longhole Mining Mucking Rates**

Mining Zone	Mucking Rate	Effective Mucking Time per Day
Lower Triangle: zones C6 to C8	1,106 tonnes / day	12 hours / day
Lower Triangle: zones C9 to C11	1,022 tonnes / day	11.1 hours / day

The mine plan, mine design parameters, mine backfilling concepts, and productivity rates are described in Section 16.

Additional capital has been allocated to development to the stopes with Mineralized Material, the development schedule is shown in Table 1-12

Mine development is optimized for this PEA, and the development and production schedules presented in this section would alter the schedules presented in Section 16. Production of Mineralized Materials would occur earlier as shown in Table 1-12, offsetting some of production profiles presented in Section 16.

**Table 1-12: PEA LOM Development Schedule**

Development Type	2025	2026	2027	2028	2029	2030	2031	2032	2033	2034	2035	2036	2037	2038	2039	2040	2041	Total
Lateral CAPEX (km)	-0.4	1.7	1.7	3.1	6.2	4.9	5.2	3.7	1.4	3.5	0.3	0.0	0.1	0.0	0.0	0.0	0.0	31.4
Vertical CAPEX (km)	-0.2	0.2	-0.1	0.4	0.3	0.3	0.3	0.2	0.1	0.1	0.2	0.0	0.0	0.0	0.0	0.0	0.0	1.7
Lateral OPEX (km)	-0.9	-0.4	-0.4	2.7	2.9	5.0	4.1	4.0	2.7	3.4	1.1	0.8	0.5	0.7	0.8	0.9	0.9	28.8
<b>Total</b>																		
Development (km)	-1.5	1.5	1.3	6.2	9.4	10.3	9.5	7.9	4.1	7.0	1.5	0.8	0.5	0.8	0.8	0.9	0.9	61.9
Development (kt)	<b>-42</b>	<b>223</b>	<b>123</b>	<b>534</b>	<b>772</b>	<b>865</b>	<b>807</b>	<b>608</b>	<b>259</b>	<b>426</b>	<b>66</b>	<b>37</b>	<b>24</b>	<b>33</b>	<b>34</b>	<b>39</b>	<b>39</b>	<b>4846</b>

Additional mining equipment will be required including three two-boom jumbos, five bolters, five LHDs, eight haul trucks and additional support equipment.

Ventilation and dewatering systems have been designed and additional equipment considered in the assessment. The equipment is included in the mine plans and capital cost allocations to support the PEA.

The geotechnical assessment is included in Section 16.10.

Mine services will be extended as required and discussed in 16.11.

### 1.24.7 PEA Project Infrastructure

The Project infrastructure described in Section 1.18 will be supplemented by an additional tailings storage facility. The historic Lamaque TSF was considered to be utilized with construction of a new facility built on the surface of the existing western section. With the new facility constructed, the planned phase 7 expansion of the Sigma TSF will not be executed as it is more capital intensive considering the additional tailings storage requirement.

### 1.24.8 PEA Capital and Operating Costs

The capital and operating cost estimates presented in the PEA are based on conceptual estimates as required to mine the additional Mineral Resources identified within the Triangle and Ormaque deposits. The capital required to implement the PEA is US\$456.8 M shown in Table 1-13.

**Table 1-13: Growth Capital Items, PEA Case**

Description	Growth (\$M)	Sustaining (\$M)	Total (\$M)
Mining	(2.1)	375.4	373.4
Processing	11.1	3.9	15.0
General and Administration	(0.3)	22.6	22.3
Infrastructure	0.0	0.0	0.0
Exploration and Delineation Drilling	23.8	18.0	41.8
Closure	0.0	4.4	4.4
Salvage (credit)	0.0	0.0	0.0
<b>Total</b>	<b>32.5</b>	<b>424.3</b>	<b>456.8</b>

Capital costs include development mining within the Triangle and Ormaque deposits, redevelopment of the historic Lamaque TSF to support a new facility on surface, exploration programs, additional processing capital for ongoing upgrades, capitalized general and administration costs, and additional closure costs for the Lamaque TSF. Development of the Sigma TSF would be reduced with lower overall costs.

The average operating cost for mining and processing the mineralized material in the PEA over the extended life of mine is estimated to be US\$180.02/t of ore or US\$851.47/oz Au. Table 1-14 provides the breakdown of the projected operating costs for the PEA case.

**Table 1-14: Operating Cost Summary**

Cost Area	Average cost (\$/tonne ore)	Average cost (\$/oz Au)
Underground Mining	128.74	608.91
Processing	26.24	124.10
General and Administration	25.04	118.46
<b>Total</b>	<b>180.02</b>	<b>851.47</b>

### 1.24.9 PEA Economic Analysis

The PEA supporting the extended LOM through inclusion of additional Mineral Resources at Triangle and Ormaque indicates an additional after-tax NPV of US\$623 M using a discount rate of 5% utilizing mid-year discounting convention. The IRR of the PEA is 43.5%.

The economic models were subjected to sensitivity analyses to determine the effects of changing metal prices, capital, and operating expenditures on financial returns. This analysis showed that the Project economics for the PEA are robust and are most sensitive to metal prices.

### 1.24.10 PEA Interpretation and Conclusions

Using the assumptions and parameters detailed for the 2024 PEA, the conceptual economic analysis returns positive economics. The sensitivity analysis indicates high sensitivity to the gold price but economics would remain robust at gold prices considerably below the current spot price.

Through the addition of additional Mineral Resources which are primarily Inferred Resources located deeper in the Triangle and Ormaque deposits, significant value is demonstrated for the Lamaque Complex.

### 1.24.11 Exploration Upside

Both the Lamaque Property and Bourlamaque Property have targets to further explore. The Triangle, Ormaque, and Parallel deposits remain open at depth. Eldorado has allocated sufficient funds to continue to explore and define the known deposits through drilling programs.

### 1.24.12 Risks and Opportunities

Risks have been assessed with the major risks identified being lower than expected conversion, paste backfill performance as it is new to the Project, changing metallurgy at depth, and underground geotechnical characteristics. Eldorado will continue to assess and mitigate risks as new information becomes available.

Opportunities include extension of the deposits at depth, discovery of new deposits, and continuing electrification of the mining equipment to both lower costs and reduce greenhouse gas emissions. Costs have been allocated to explore these and other opportunities.

## 1.25 Interpretation and Conclusion

The results of this Technical Report demonstrate that the Lamaque Complex warrants continued development due to its positive, robust economics. To date, the qualified persons are not aware of any fatal flaws in the assessments of the Lamaque Complex, and the results are considered sufficiently reliable to guide Eldorado management in a decision to further advance development and investment. It is concluded that the work completed in this study indicates that the exploration information, mineral resource, and project economics are sufficiently defined to indicate that the Lamaque Complex continues to be technically and economically viable.

The main risk to the future performance of the Lamaque Complex is conversion of Inferred Resources to Measured and Indicated Mineral Resources and to Mineral Reserves. An exploration program is ongoing to further define the ore bodies within the Lamaque Complex, and capital spending is linked to successful conversion of sufficient tonnage to Mineral Reserves prior to investing capital. The second largest risk is gold price devaluation. The gold price sensitivity has been tested to \$1,450/ oz and the project remains viable. Gold price and production are monitored by Eldorado in conjunction with capital spending; systems are in place to allow for quick response to fluctuating metal prices to preserve capital in low price environments or generate growth in high price environments.

## 1.26 Recommendations

It is recommended to continue with the exploration programs ongoing and budgeted in 2025 and beyond. It is also recommended to expediently continue with ongoing studies and initiate studies identified in the report in preparation for the execution projects starting in 2025.

Table 1-15 is a description of the recommended steps in the continued advancement of the Lamaque Project and summarizes the estimated cost including advancement of engineering for the paste plant, Ormaque infrastructure, tailings storage studies, and environmental studies..

**Table 1-15: Proposed Work Program and Budget**

Item	Cost (\$M)
Geology and exploration programs (Growth)	28.0
Mine planning and operational improvement studies	1.4
Metallurgical and processing improvement studies.	1.9
Permitting support and closure studies	0.7
<b>Total</b>	<b>32.0</b>

## 2 Introduction

Eldorado Gold Corporation (Eldorado), an international gold and base metal mining company based in Vancouver, British Columbia, owns and operates the Lamaque Complex.

As a preliminary comment, this report uses the terms "Lamaque Property", "Lamaque Complex" and the "Project" or the "Lamaque Project" throughout. These descriptive terms are more specifically described and distinguished as follows:

- The Lamaque Property consists of 76 map designated claims (Exploration Claims (CDC), 1,452 ha), 10 mining concessions (Mining Concessions (CM), 2,325 ha) and one mining lease (Mining Lease (BM), 76 ha), all of which are in good standing at the time of this report. References to the Lamaque Property are used when describing mining claim boundaries.
- The Project or the Lamaque Project is also known and referred to as the Lamaque Complex. The Lamaque Complex is fully within the larger Lamaque Property boundaries. The Lamaque Complex includes the following:
  - Triangle mine (upper and lower zones), within the Triangle deposit
  - Sigma-Triangle decline (between the Sigma mill and level 0400 of the Triangle mine)
  - Future Ormaque mine within the Ormaque deposit
  - Parallel deposit (future mining operations)
  - Plug No. 4 deposit
  - Sigma mill
  - Sigma tailings storage facilities (Sigma TSF)
  - Infrastructure of the historic Sigma mine (surface pit and underground)
  - Mining infrastructure of the historic Lamaque mine (underground)
  - Historic Lamaque tailings storage facilities (Lamaque TSF)
  - Regional office
  - Exploration office and core yard

The Lamaque Complex is owned by Eldorado through its wholly owned subsidiary Eldorado Gold Québec Inc. (EGQ). The Lamaque Complex is located east of Val d'Or in Northern Québec.

Eldorado prepared this Technical Report to provide an overall update on the Lamaque Complex. This includes a prefeasibility-level update to the current operation based on commercial production from Mineral Reserves as well as a Preliminary Economic Assessment of Inferred Resources from the Triangle and Ormaque deposits. This report has been prepared in accordance with Canadian Securities Administrators' National Instrument 43-101 *Standards of Disclosure for Mineral Projects* (NI 43 101) and its related Form 43 101F1.

When estimating mineralized material for any of its projects, Eldorado uses a consistent prevailing gold price methodology that is in line with the 2015 CIM Guidance on Commodity Pricing used in Resource and Reserve Estimation and Reporting. These are the lesser of the three-year moving average and the current spot price. For Eldorado's current Mineral Reserve estimations, a gold price of US\$1,450/oz Au was used. All cut-off grade determinations, mine designs, and economic tests of economic extraction used this pricing for the Lamaque Complex Mineral Reserves.

To demonstrate the potential economics of a project, Eldorado may elect to use metal pricing closer to the current prevailing spot price and then provide some sensitivity around this price (for the Lamaque Complex metal prices used for this evaluation were US\$2,000/oz Au). Eldorado stresses that only material that satisfies the mineralized material criteria is subjected to further economic assessments at varied metal pricing.

The Lamaque Property consists of 10 mining concessions totalling 2,325 ha is the amalgamation of the Sigma-Lamaque, Lamaque South, and Aumaque properties. The Lamaque Complex consists of the Triangle mine, future Ormaque mine and Sigma mill; the Project includes the following facilities and infrastructure:

- Triangle mine (upper and lower), within the Triangle deposit
- Sigma-Triangle decline
- Future Ormaque mine within the Ormaque deposit
- Parallel deposit (future mining operations)
- Plug No. 4 deposit
- Sigma mill
- Sigma tailings storage facilities (Sigma TSF)
- Infrastructure of the historic Sigma mine (surface pit and underground)
- Mining infrastructure of the historic Lamaque mine (underground only)
- Historic Lamaque tailings storage facilities (Lamaque TSF)
- Regional office
- Exploration office and core yard

Eldorado purchased QMX Gold Corporation in 2020 and acquired the Bourlamaque Property adjacent to the Lamaque Property. There are no Mineral Resources reported from the Bourlamaque Property.

This report is solely for the Lamaque Property and does not consider the Bourlamaque Property nor use of any existing any infrastructure on the Bourlamaque Property to support this Technical Report.

## 2.1 Principal Sources of Information

Eldorado and the authors believe the information used to prepare the Technical Report and to formulate its conclusions and recommendations is valid and appropriate considering the status of the Project and the purpose for which the report is prepared. The authors, by virtue of their technical review of the Project, affirm that the work program and recommendations presented in the report are in accordance with NI 43-101 and CIM Definition Standards for Mineral Resources and Mineral Reserves.

The external experts and QPs do not have, nor have they previously had, any material interest in Eldorado or its related entities.

The quality of information, conclusions, and estimates contained herein is based on i) information available at the time of preparation, ii) data supplied by outside sources, and iii) the assumptions, conditions, and qualifications set forth in this Technical Report. This Technical Report is intended for use by Eldorado subject to the relevant securities legislation. Eldorado is permitted to file this Technical Report as a “technical report” with Canadian securities regulatory authorities pursuant to NI 43-101 and with the U.S. securities regulatory authorities pursuant to the multijurisdictional disclosure system of the United States Securities Exchange Act of 1934, as amended. Except for the purposes legislated under Canadian securities law and U.S. securities law, any other uses of this report by any third party are at that party’s sole risk. The user of this document should ensure that this is the most recent Technical Report for the property as it is not valid if a new Technical Report has been issued.

Principal sources of information include operating data, budgets, internal designs, and information by third-party experts listed in Section 3, external references are listed in Section 26.

## 2.2 Qualified Persons and Inspection on the Project

The Technical Report was assembled by Eldorado. The QPs for the Technical Report are as follows.

- Mr. David Sutherland, P.Eng., Eldorado, author of items 1, 2, 3, 5, 12.2.1, 19, 20, 24.1, 24.2, 24.3, 24.5, 24.12, 24.19, 24.20, 24.24 through 24.26, 25, and 26
- Mr. Jacques Simoneau, P.Geo., Eldorado, author of items 4, 6, 7, 8, 9, 10, 11, 12.2.2, 23, 24.4, 24.6 through 24.11, and 24.23
- Mr. Peter Lind, Eng., P.Eng., Eldorado, author of items 12.2.3, 13, 17, 24.13, and 24.17
- Mr. Jessy Thelland, P.Geo., Eldorado, author of items 12.1, 12.2.4, 14, 15, 16, 21, 22, 24.14, 24.15, 24.16, 24.21, 24.22
- Mr. Philippe Groleau, Eng., Eldorado author of items 12.2.5, 15.3, 16, 18.6, 21, 24.15, and 24.16 specific to the Ormaque deposit.
- Mr. Mehdi Bouanani, Eng., Eldorado author of items 12.2.6, and 18.1 through 18.5, 18.7 through 18.9, 18.13, and 24.18
- Mr. Vu Tran, Eng., Eldorado, author of items 12.2.7, 18.10, 18.11, 18.12, and 24.18.1

## 2.3 Site Visits

Numerous site visits listed below and inspections were conducted in preparation of the Technical Report. Sessions were held on site with a majority of the QPs in attendance to align with the site staff including the resident QPs and to familiarize themselves with the Lamaque Project.

- Mr. David Sutherland works full time for Eldorado, since June 2008, and starting in 2021 has had numerous visits to the Lamaque Project with the most recent visit occurring May 28 to 30, 2024 for discussions regarding the Technical Report and infrastructure designs.
- Mr. Jacques Simoneau, works full time for EGQ, since February 2015, and is on site on regular intervals.
- Mr. Peter Lind works full time for Eldorado since May 2021, visited the Lamaque Project on numerous occasions with the most recent visit occurring September 16, 2024 to review budgets and metallurgical testwork results.
- Mr. Jessy Thelland works full time on site for EGQ, since September 2016.
- Mr. Philippe Groleau works full time on site for EGQ, since July 2023.
- Mr. Mehdi Bouanani works full time for EGQ, since November 2017 and is on site on regular intervals.
- Mr. Vu Tran works full time for EGQ, since May 2021 and is on site on regular intervals.

## 2.4 Effective Date

The effective date of this Technical Report is December 31, 2024.

## 2.5 Abbreviations, Units, and Currencies

All currency amounts are stated in US dollars (US\$) unless noted otherwise. Quantities are stated in metric units, as per standard Canadian and international practice, including metric tonnes (tonnes, t) and kilograms (kg) for weight, kilometres (km) or metres (m) for distance, hectares (ha) for area, and gram per metric ton (g/t) for gold grades. Gold sales and price are in troy ounces. Short tons are used in Section 6.1 regarding historical productions (pre-1996) converted to metric tonnes in summation tables.

### **3 Reliance on Other Experts**

Eldorado prepared this document with input from the Lamaque Complex staff, other well qualified individuals, and experts.

The qualified persons are not experts concerning legal, political, environmental or tax matters relevant to the Technical Report, they have assumed and relied on a report, opinion or statements by information provided by Eldorado report as follows:

#### **3.1 Property Agreements, Mineral Tenure, Surface Rights, and Royalties**

The qualified persons have not independently reviewed ownership of the Lamaque Complex, the Project area and any underlying property agreements, mineral tenure, surface rights, or royalties. The QPs have fully relied upon, and disclaim responsibility for, information derived from Eldorado.

#### **3.2 Political**

The qualified persons have not reviewed political risks or issues in relation to the Project.

#### **3.3 Environmental, Permitting, Closure, Social, and Community**

The qualified persons have fully relied upon, and disclaim responsibility for, information supplied by Eldorado for information related to environmental permitting, permitting, filed closure plans, and social and community impacts.

#### **3.4 Taxation**

The qualified persons have fully relied upon, and disclaim responsibility for, information supplied by Eldorado for information related to taxation as applied to the financial model.

#### **3.5 Markets**

The qualified persons have not independently reviewed the marketing information. The QPs have fully relied upon, and disclaim responsibility for, information derived from Eldorado.

## 4 Property Description and Location

### 4.1 Location

The Lamaque Complex is situated immediately east of the city of Val-d'Or in the province of Québec, Canada, approximately 550 km northwest of Montréal. The coordinates for the approximate centre of the Triangle deposit are latitude 48°4'38" N and longitude 77°44'4" W, and for the approximate centre of the Ormaque deposit are latitude 48°5'35" N and longitude 77°44'45" W. According to the Canadian National Topographical System (NTS), the complex is situated on map sheets 32C/04 and 32C/03, between UTM coordinates 295,700 mE and 296,900 mE, and between 5,328,200 mN and 5,329,350 mN (NAD83 projection, Zone 18N). Figure 4-1 shows the location of the Lamaque Complex.



Figure 4-1: Location of the Lamaque Complex in the Province of Québec (Eldorado, 2024)

### 4.2 Property Description

#### 4.2.1 Land Tenure

The Government of Québec recognizes 13 types of land registration for mining and exploration. The Lamaque Property consists of 76 map designated claims (Exploration Claims (CDC), 1,452 ha), 10 mining concessions (Mining Concessions (CM), 2,325 ha) and one mining lease (Mining Lease (BM), 76 ha), all of which are in good standing at the time of this report. To be kept in good standing, exploration claims must be renewed every 2 years and have a defined amount of exploration work performed during that period. Exploration expenditures on a specific claim that exceeds the required amount can be applied to other claims located within a maximum radius of 4.5 km. Mining leases are good for 20 years but can be renewed for three additional 10-year periods. Five-year extensions can then be obtained thereafter. To keep the mining lease in good standing, the lease holder needs to pay a yearly rent based on the size of the lease. Mining concessions are grandfathered and never expire.

Pursuant to a number of amalgamations and changes of name, as of July 2020, all the claims, mining concessions, and the mining leases forming the Lamaque Property (presented in Figure 4-2), have been

registered in the name of EGQ. A complete list of the mining concessions, mining leases, and mineral claims is shown in Table 4-1.

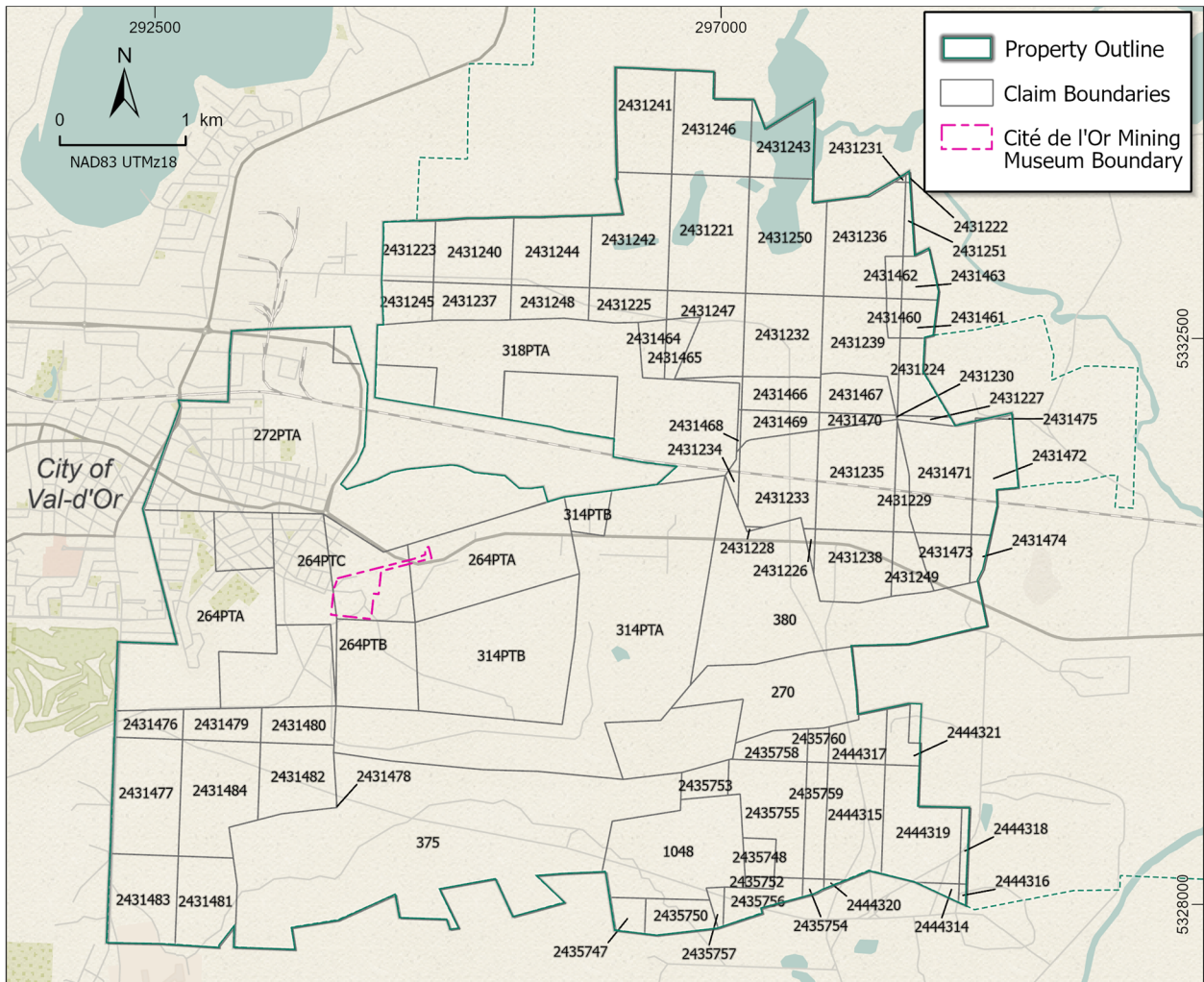

Source GESTIM (MERN), Government of Québec (as of December 31, 2024)

**Figure 4-2: Claim Map of the Lamaque Complex Near Val-d'Or, Québec, Canada (Eldorado, 2024)**

Table 4-1 Lamaque Project Mining Lease, Mining Concessions and Exploration Claims

Project	Type	Title No.	Hectares	Status	Expiry	Company
Lamaque	BM	1048	75.78	Active	2038-03-13	EQC
<b>TOTAL</b>		<b>1 Mining Lease</b>	<b>75.78</b>			
Lamaque	CM	264PTA	275.54	Active	No expiry	EGQ
Lamaque	CM	264PTA	81.65	Active	No expiry	EGQ
Lamaque	CM	264PTB	279.38	Active	No expiry	EGQ
Lamaque	CM	264PTC	82.69	Active	No expiry	EGQ
Lamaque	CM	270	66.67	Active	No expiry	EGQ
Lamaque	CM	272PTA	311.92	Active	No expiry	EGQ
Lamaque	CM	314PTA	401.11	Active	No expiry	EGQ
Lamaque	CM	314PTB	116.89	Active	No expiry	EGQ
Lamaque	CM	314PTB	10.08	Active	No expiry	EGQ
Lamaque	CM	318PTA	178.11	Active	No expiry	EGQ
Lamaque	CM	375	325.30	Active	No expiry	EGQ
Lamaque	CM	380	195.70	Active	No expiry	EGQ
		<b>10 Mining Concessions</b>	<b>2,325.04</b>			
Lamaque	CDC	2431221	57.50	Active	2026-05-15	EGQ
Lamaque	CDC	2431222	0.28	Active	2026-05-15	EGQ
Lamaque	CDC	2431223	19.50	Active	2026-05-15	EGQ
Lamaque	CDC	2431224	16.33	Active	2026-05-15	EGQ
Lamaque	CDC	2431225	16.08	Active	2026-05-15	EGQ
Lamaque	CDC	2431226	1.70	Active	2026-05-15	EGQ
Lamaque	CDC	2431227	2.31	Active	2026-05-15	EGQ
Lamaque	CDC	2431228	0.31	Active	2026-05-15	EGQ
Lamaque	CDC	2431229	8.07	Active	2026-05-15	EGQ
Lamaque	CDC	2431230	0.02	Active	2026-05-15	EGQ
Lamaque	CDC	2431231	0.25	Active	2026-05-15	EGQ
Lamaque	CDC	2431232	40.61	Active	2026-05-15	EGQ
Lamaque	CDC	2431233	43.45	Active	2026-05-15	EGQ
Lamaque	CDC	2431234	2.52	Active	2026-05-15	EGQ
Lamaque	CDC	2431235	52.12	Active	2026-05-15	EGQ
Lamaque	CDC	2431236	46.82	Active	2026-05-15	EGQ
Lamaque	CDC	2431237	18.07	Active	2026-05-15	EGQ
Lamaque	CDC	2431238	34.27	Active	2026-05-15	EGQ
Lamaque	CDC	2431239	36.18	Active	2026-05-15	EGQ
Lamaque	CDC	2431240	31.73	Active	2026-05-15	EGQ
Lamaque	CDC	2431241	37.16	Active	2026-05-15	EGQ
Lamaque	CDC	2431242	49.99	Active	2026-05-15	EGQ
Lamaque	CDC	2431243	25.69	Active	2026-05-15	EGQ

Project	Type	Title No.	Hectares	Status	Expiry	Company
Lamaque	CDC	2431244	34.11	Active	2026-05-15	EGQ
Lamaque	CDC	2431245	13.18	Active	2026-05-15	EGQ
Lamaque	CDC	2431246	44.42	Active	2026-05-15	EGQ
Lamaque	CDC	2431247	33.91	Active	2026-05-15	EGQ
Lamaque	CDC	2431248	16.18	Active	2026-05-15	EGQ
Lamaque	CDC	2431249	12.39	Active	2026-05-15	EGQ
Lamaque	CDC	2431250	55.49	Active	2026-05-15	EGQ
Lamaque	CDC	2431251	4.27	Active	2026-05-15	EGQ
Lamaque	CDC	2431460	3.49	Active	2026-11-21	EGQ
Lamaque	CDC	2431461	8.64	Active	2026-11-21	EGQ
Lamaque	CDC	2431462	4.40	Active	2026-11-21	EGQ
Lamaque	CDC	2431463	9.60	Active	2026-11-21	EGQ
Lamaque	CDC	2431464	9.08	Active	2026-11-21	EGQ
Lamaque	CDC	2431465	10.60	Active	2026-11-21	EGQ
Lamaque	CDC	2431466	16.90	Active	2026-11-21	EGQ
Lamaque	CDC	2431467	17.84	Active	2026-11-21	EGQ
Lamaque	CDC	2431468	0.81	Active	2026-11-21	EGQ
Lamaque	CDC	2431469	12.27	Active	2026-11-21	EGQ
Lamaque	CDC	2431470	5.38	Active	2026-11-21	EGQ
Lamaque	CDC	2431471	46.18	Active	2026-11-21	EGQ
Lamaque	CDC	2431472	25.24	Active	2026-11-21	EGQ
Lamaque	CDC	2431473	16.02	Active	2026-11-21	EGQ
Lamaque	CDC	2431474	4.73	Active	2026-11-21	EGQ
Lamaque	CDC	2431475	0.31	Active	2026-11-21	EGQ
Lamaque	CDC	2431476	12.00	Active	2026-04-30	EGQ
Lamaque	CDC	2431477	49.26	Active	2026-04-30	EGQ
Lamaque	CDC	2431478	0.01	Active	2026-04-30	EGQ
Lamaque	CDC	2431479	16.07	Active	2026-04-30	EGQ
Lamaque	CDC	2431480	17.20	Active	2026-04-30	EGQ
Lamaque	CDC	2431481	32.62	Active	2026-04-30	EGQ
Lamaque	CDC	2431482	32.98	Active	2026-04-30	EGQ
Lamaque	CDC	2431483	37.93	Active	2026-04-30	EGQ
Lamaque	CDC	2431484	51.80	Active	2026-04-30	EGQ
Lamaque	CDC	2435747	6.99	Active	2026-01-24	EGQ
Lamaque	CDC	2435748	7.56	Active	2026-01-24	EGQ
Lamaque	CDC	2435750	14.85	Active	2026-01-24	EGQ
Lamaque	CDC	2435752	2.07	Active	2026-01-24	EGQ
Lamaque	CDC	2435753	9.28	Active	2026-09-15	EGQ
Lamaque	CDC	2435754	2.19	Active	2026-09-15	EGQ

Project	Type	Title No.	Hectares	Status	Expiry	Company
Lamaque	CDC	2435755	41.59	Active	2026-09-15	EGQ
Lamaque	CDC	2435756	13.91	Active	2026-09-15	EGQ
Lamaque	CDC	2435757	3.01	Active	2026-09-15	EGQ
Lamaque	CDC	2435758	12.58	Active	2026-09-15	EGQ
Lamaque	CDC	2435759	15.43	Active	2026-09-15	EGQ
Lamaque	CDC	2435760	4.55	Active	2026-09-15	EGQ
Lamaque	CDC	2444314	2.61	Active	2025-06-30	EGQ
Lamaque	CDC	2444315	40.95	Active	2025-06-30	EGQ
Lamaque	CDC	2444316	1.10	Active	2025-06-30	EGQ
Lamaque	CDC	2444317	16.57	Active	2025-06-30	EGQ
Lamaque	CDC	2444318	4.17	Active	2025-06-30	EGQ
Lamaque	CDC	2444319	45.68	Active	2025-06-30	EGQ
Lamaque	CDC	2444320	0.92	Active	2025-06-30	EGQ
Lamaque	CDC	2444321	10.17	Active	2025-06-30	EGQ
		<b>76 Claims</b>	<b>1,452.25</b>			

One of the previous operators, Teck Cominco Limited (now Teck Resources Limited), granted rights to part of the surface area of the historical Lamaque Mine to the city of Val-d'Or for use as a mining museum, which opened in 1996 (see Figure 4-4). The museum is managed by the non-profit organization Corporation du Village Minier de Bourlamaque (La Cité de l'Or). The area includes the headframes, the surviving mine buildings, and 100 m of decline into the Lamaque No.2 mine.

The Lamaque Property represent the amalgamation of three separate but contiguous property blocks of designated mining and exploration claims: Lamaque South, Sigma-Lamaque, and Aumaque (refer to Figure 4-3), previously registered to Integra Gold and Or Integra. In 2017, Eldorado acquired all the issued and outstanding shares of Integra Gold and became the sole owner of the Lamaque Complex.

Subsequent to this, in 2021 EGQ acquired QMX Gold and through this a large block of claims located east of the Lamaque Property termed the Bourlamaque Block. Activities on the Bourlamaque Block are extremely preliminary and in early stages of planning. Eldorado has no Mineral Resources to report on the Bourlamaque Block. Because it is considered an early-stage exploration which is being evaluated for prospectivity separately from activities on the Lamaque Property, the Bourlamaque Block is excluded in scope for the purposes of this Technical Report (that is, the Technical Report is focused on the Lamaque Property).

Eldorado is currently exploiting the upper zones of the Triangle deposit on the Lamaque South property via surface ramp access. The Triangle deposit is almost exclusively situated within mining lease 1048 and a small portion within the mining concession No. 375. The ramp portal is also located within the same mining concession. The ore is transported to the Sigma mill, located on mining concession 272PTA, where it is processed.

The Lamaque Complex also includes the historical Sigma open pit, underground mine, all associated infrastructure, and the historical Lamaque open pit and underground mine. The underground workings of the historic Lamaque mine comprise levels 1 to 36 (1,100 m) at a vertical spacing of 30 m, whereas those of the historic Sigma mine comprise levels 1 to 40 (1,850 m) at variable vertical spacings.

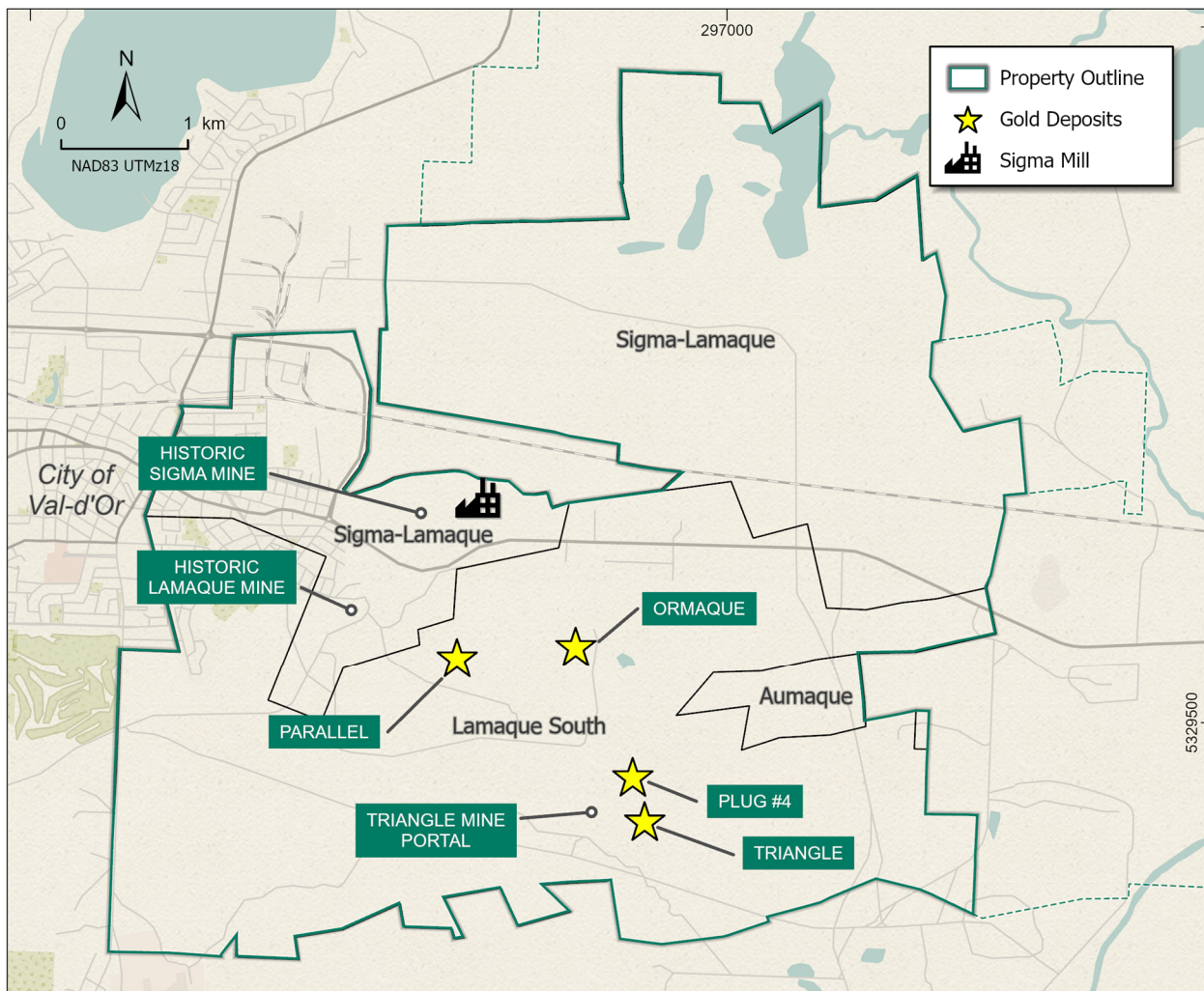

**Figure 4-3: Location of the Lamaque Complex with Respect to the City of Val-d'Or (Eldorado, 2024)**

EGQ holds all surface rights, mining concessions and legal access to operate the Lamaque Complex.

## 4.2.2 Royalties

The Lamaque Complex has been the subject of several agreements in the past involving multiple companies. Although all the claims, mining concessions and mining leases of the project are 100% owned by EGQ, several of these past agreements included royalties to various companies. The following text is a summary of these agreements. Table 4-2 summarizes the current royalties on the project and Figure 4-4 is a map showing the locations of where these royalties apply.

The group of claims and mining concessions from the Lamaque, Roc d'Or West and Roc D'Or East historical properties are currently subject to a 1% Net Smelter Return (NSR) royalty to Osisko Royalties of which 0.15% (15% of 1%) is owned by its financial partners. This royalty was purchased by Osisko from Teck in 2015 and was originally granted to Teck from a series of joint venture agreements with Golden Pond Resources Ltd and Tundra Gold Mines Inc. and Kalahari Resources Inc. (the predecessor company to Integra Gold) following the closure of the Lamaque mine in 1985. This royalty was originally 2% but Eldorado exercised the buyback clause in 2019 to purchase 1%. A 2% NSR royalty exists on the small triangle shape claim known as the Roc d'Or East Extension property. This royalty came from a joint venture agreement between Kalahari Resources

Inc. and Alexandria. On September 22, 2009, Kalahari fulfilled this agreement to earn 100% of the property over a three-year period leaving the 2% NSR royalty to Alexandria which was purchased by Sandstorm in 2015. In 2020, Eldorado exercised the buyback for 1% of the royalty on the Roc d'Or East Extension (CL 3691171) royalty owned by Sandstorm.

**Table 4-2: Royalties Summary Table**

Property	Owner	Royalty Type	%	NSR Company	Buyback Clause	Amount CAD\$	Comment
Sigma-Lamaque	Eldorado Gold Québec Inc.	None					
Aumaque	Eldorado Gold Québec Inc.	None					
Lamaque	Eldorado Gold Québec Inc.	NSR	1%	Osisko Royalties (0.85%), Osisko financial partners (0.15%)			Osisko acquired NSR royalty from Teck in 2015. Eldorado purchased 1% from Osisko in 2019, as per its agreement
Roc d'Or West							
Roc d'Or East							
Roc d'Or East Extension (CL 3691171)	Eldorado Gold Québec Inc.	NSR	2%	Sandstorm	1%	1M	Triangle Claim. Sandstorm acquired NSR royalty from Alexandria in 2015. Buyback was exercised in 2020
Bourlamaque	Eldorado Gold Québec Inc.	None					
Donald	Eldorado Gold Québec Inc.	GMR	3%	Globex	1%	750K	
McGregor	Eldorado Gold Québec Inc.	NSR	2%	Jean Robert (0.6%)	1%	500K	
				Les Explorations Carat (0.6%)			
				Albert Audet (0.8%)			

In December 2010, Integra acquired an option to earn a 100% interest in the historic Bourlamaque Property (2 claims; 16 hectares) in Bourlamaque Township, adjacent to the Lamaque Project. In addition to fulfilling the terms of the agreement, Integra also purchased the entire NSR royalty for CAD\$5,000 on April 30, 2013. Therefore, there is no outstanding royalty on the Bourlamaque Property. Please note the Bourlamaque Property shown in Figure 4-4 is separate from the Bourlamaque Block purchased from acquired QMX Gold.

There are no other royalties, back-in rights, payments, agreements, or encumbrances to which the Lamaque Complex is subject.

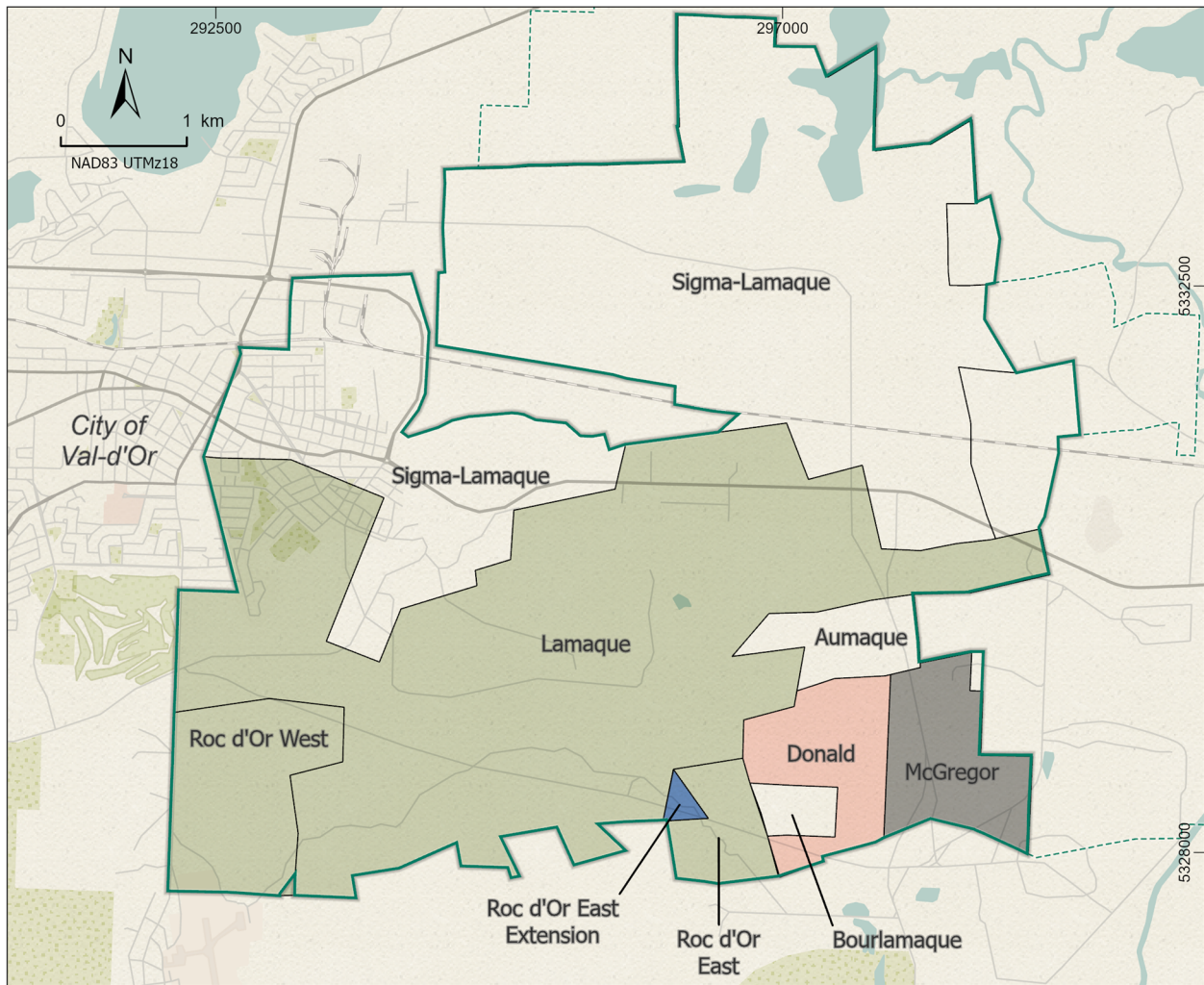

**Figure 4-4: Location of Historical Properties in Relation to Royalties (Eldorado, 2024)**

In June 2011, Integra entered into an option agreement to acquire a 100% interest in the McGregor Property, which is subject to a 2% NSR royalty, 0.6% of which is payable to Jean Robert, 0.6% to Les Explorations Carat and the remaining 0.8% to Albert Audet. One-half (1%) of this NSR royalty may be purchased for CAD\$500,000.

In January 2012, Integra entered into an option agreement to acquire a 100% interest in the Donald Property which is subject to a 3% gross metal royalty payable to Les Entreprises Minière Globex Inc., one-third (1%) of which may be purchased for CAD\$750,000.

### 4.2.3 Exploration Permit

In January 2021, a new permitting process was put into place by Ministère de l'Environnement et Lutte Contre le Changement Climatiques (MELCC) for all activities conducted within the environment that are perceived as a risk to the environment. These areas are mainly defined as wetland areas, which make up a significant portion of the ground in the Abitibi region. This new permitting process (REAFIE) involves an online application and payment of relevant fees. The government has 30 days to reply with any questions or concerns about the program. If there are no concerns, the application is accepted.

For exploration activities outside of wetland areas, only regular “Permis d’Intervention en Forêt” must be obtained from the Ministère de Forêts, Faune et Parcs (MFFP) to conduct drilling, trenching, stripping or any other surface disturbance on the property. These permits need to be obtained each time a surface disturbance is contemplated. To obtain these permits, the claim holder must indicate the location, the type of work that will be conducted and the volume of wood (m<sup>3</sup>) cut from the forest validated by an independent forestry engineer, on the application. The permits can usually be obtained within a month from MFFP.

At the Lamaque Project, a portion of the exploration activity is carried out on a historic Tailing Storage Facility (TSF) in very close proximity to the Triangle mine and the Ormaque deposit, which is still under the reclamation and restoration responsibility of the previous operator. For the exploration work on the TSF EGQ filed a specific Reclamation and Remediation Plan (RRP) with the Ministry of Energy and Natural Resources (MERN) each time EGQ conducted exploration programs from the TSF. The update of the registered RRP 8341-0199 associated with the TSF footprint was accepted by MERN on February 8, 2022 and is in good standing. No permit is needed if mapping, sampling, and geophysical surveys are to be conducted on the mineral claims, provided there is no disturbance of the natural environment.

#### 4.2.4 Operating Permits

All permits, both Federal and Provincial, required to operate the Lamaque Project have been acquired and are in good standing for the operation of the Lamaque Complex. The Lamaque Complex currently holds several Certificate of Authorizations (CoA), CofA 7610-08-01-70182-29, covers the Triangle deposit and CofA 7610-08-01-70095-28 covers the Sigma mill and Sigma TSF.

Surface claim and concession boundaries are vertical and extend to depth. A portion of the Triangle, lower in the deposit in zone C10, is outside the mining concession in CofA 7610-08-01-70182-29 and will require an extension of mining lease BM-1048 before extraction. Mineral Reserves must be declared prior to application for an operating permit. With the Bill Omnibus No 103 adopted on October 6, 2021, an Act to amend various legislative provisions primarily for the purpose of reducing the administrative burden, art. 104.1 will be added to the Québec Mining Law to allow the extension of a mining lease requiring five conditions to be met, precisely the scenario of EGQ with the future extension of BM-1048.

The Parallel deposit and Ormaque deposit are included in CoA 7610-08-01-70095-31. An amendment to the CoA will be required to mine below a depth of 453 m. Ore must be classified as Mineral Reserves prior to application for the amendment.

Federal and Provincial regulations and permitting regarding mining operations are fully described in Section 1.

#### 4.2.5 Approved Closure Plans

To the extent known, there are no significant factors or risks besides those discussed in this report that may affect access, title, or the issuer’s right or ability to perform work on the Lamaque Project.

EGQ is managing three distinct Remediation and Reclamation Plans (RRP) as listed in Table 4-3.

**Table 4-3: Remediation and Reclamation Plans**

RRP N°	RRP Name	Acceptance	Renewal	Surety Bonds CAD\$
8341-0184	Sigma (mill + TSF site)	Jan 14, 2022	Jan 14, 2027	7,514,829
8341-0199	Exploration	Feb 7, 2022	Feb 7, 2027	567,664
8341-0247	Lamaque South (Triangle mine site)	Aug 01, 2024	Aug 01, 2029	5,060,600

As shown, the RRP Plans for the Lamaque Complex are current and all within the 5-year legal renewal period.

The posted surety bonds total CAD\$13,143,093. Based on a recent evaluation performed in December 2024 by an independent firm, the cost for the RRP is estimated at CAD\$13,143,093.

These three RRP follow the strict guidelines for preparing mine closure plans in Québec last published by the Provincial MERN in November 2017 (ISBN 978-2-550-79804-0 PDF) including the post-closure monitoring (physical stability, environmental, agronomical), maintenance program, and the Emergency Response Plan prior to any approval.

Environment liabilities for project closure are stated in the approved RRP filings, the RRP's are amended and approved prior to initiation of any new construction or operational activities not described in the applicable RRP. There are no other known environment liabilities regarding the Lamaque Complex.

#### **4.2.6 Location of Mineralization**

All mineralized zones or areas that the issuer plans to explore for potential exploit of gold deposits that are the subject of this report are located within the boundaries of the Lamaque Property.

## 5 Accessibility, Climate, Local Resources, Infrastructure and Physiography

### 5.1 Accessibility

The Lamaque Complex is located on the eastern edge of the City Val-d'Or in the Province of Québec 430 km north-west of Montréal. Val-d'Or is approximately 600 km by road northwest of Montréal and is connected to the Provincial highway system in multiple directions. There is daily bus service between Montréal and other cities in the Abitibi region.

The region is serviced by the Val-d'Or Regional Airport, IATA code YVO, located 3 km south of Val d'Or which has regularly scheduled flights to and from Montréal. The airport is a national hub for Northern Québec (Cree Nation and Nunavik) and the Canadian arctic territory of Nunavut for several mining companies and can accommodate long-haul aircraft on its 3,000 m long paved airstrip. It is also Western Québec's hub for forest firefighting with CL-215 water bombers stationed at the airport. The proximity of this strategic airport allows for a portion of the staff to commute from the Montréal region and provides quick access to spare parts and equipment.

Canadian National Railroad (CN) operates a feeder line that runs through Senneterre and Amos, connecting to the North American rail system eastward through Montréal and westward through the Ontario Northland Railway. A CN branch line runs through Val-d'Or and crosses the Lamaque Project, rail and water routes are shown in Figure 5-1.

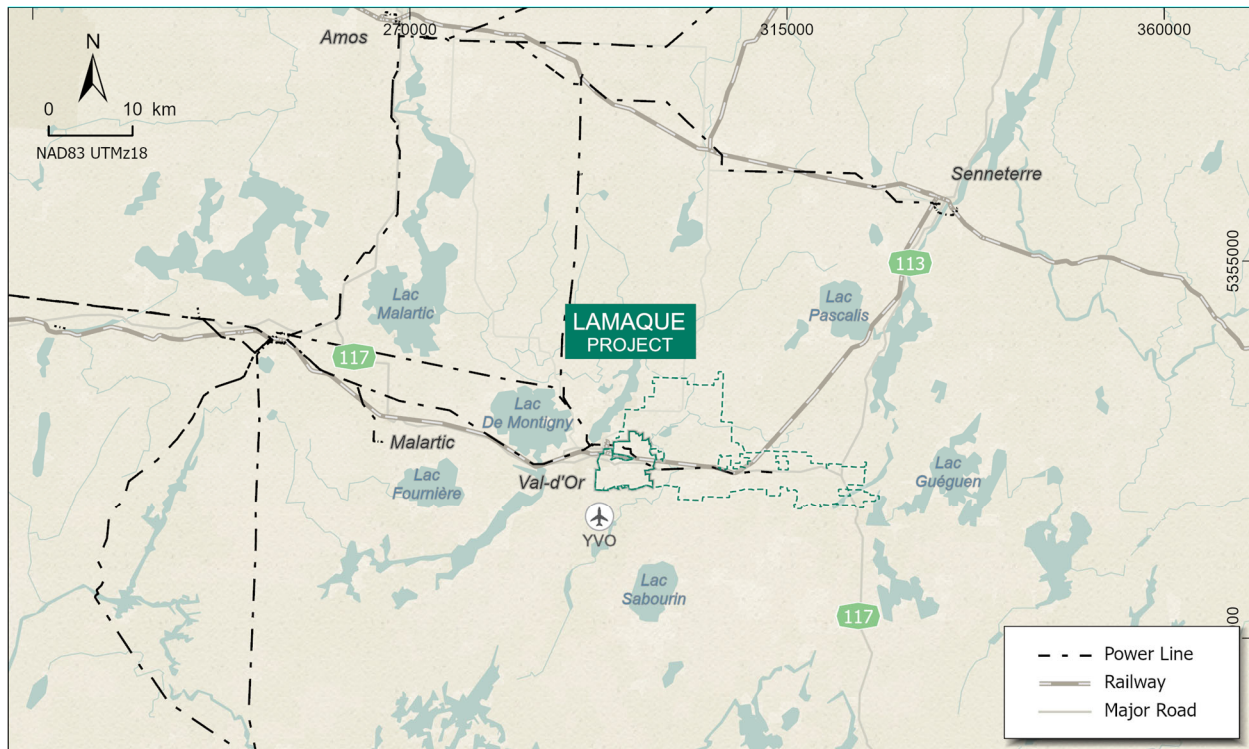

**Figure 5-1: Access and Waterways of the Lamaque Complex and Region (Eldorado 2024)**

The Triangle mine site is accessed off Voie de Service Goldex Manitou, a private gravel road 3.7 km east of the intersection of boulevard Barrette and 7<sup>e</sup> rue. Ore processing occurs at the Sigma mill that is accessible

via Provincial Highway 117, the Trans-Canada Highway, and is 1.3 km east of the first intersection entering Val-d'Or at Saint-Jacques Street and 3rd Avenue, Figure 5-2. Work is conducted year around at the Lamaque Complex without limitations to access.

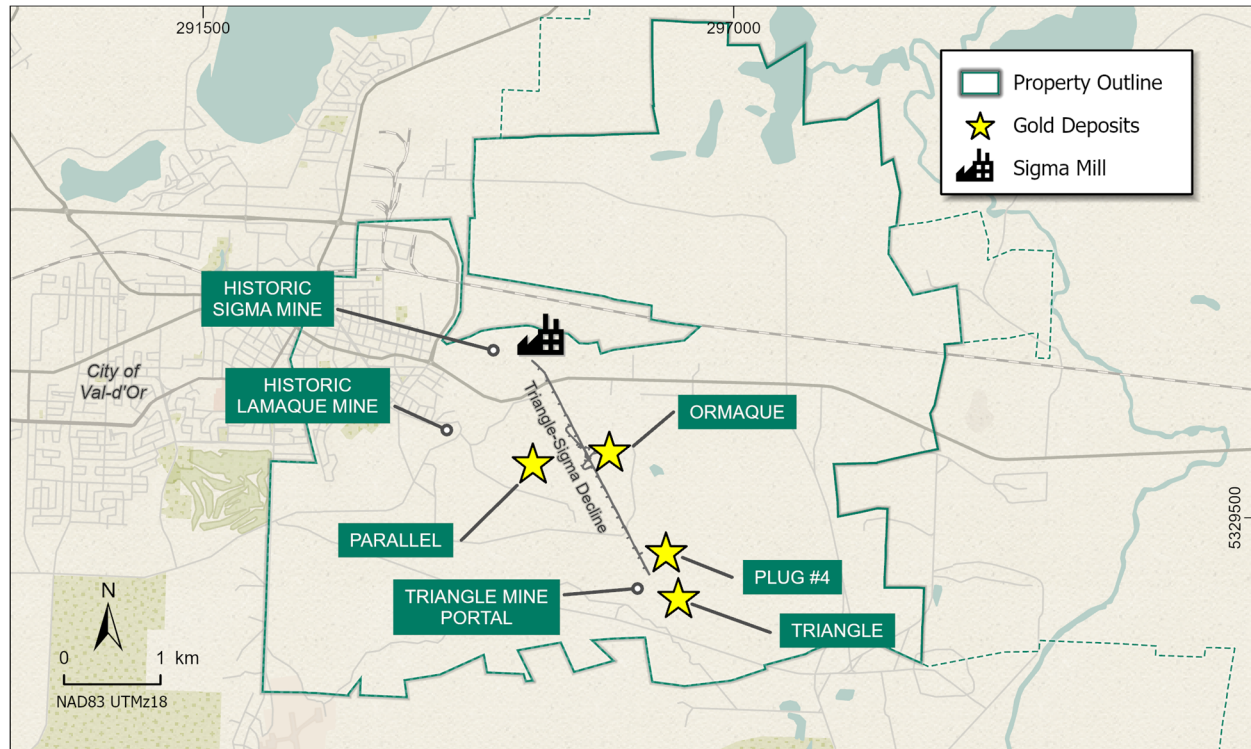

Figure 5-2: Location and Access of the Lamaque Complex (Eldorado 2024)

## 5.2 Climate

The city of Val-d'Or has a humid continental climate that closely borders on a subarctic climate. Winters are cold and snowy, and summers are warm and damp. Key climatic variables that describe this type of climate are summarized in the following sections for temperatures, precipitations, evaporation – evapotranspiration, and winds.

### 5.2.1 Temperature

Based on climatic norms for Val-d'Or Airport weather stations (Environment Canada) for the period 1995 to 2024, the region is characterized by a mean daily temperature of 1.9 °C (Table 5-1). The mean lowest daily value is -16.9 °C while the mean highest value is 17.6 °C.

Over the same period, the extreme minimum recorded daily temperature was -40.6 °C and the extreme maximum recorded daily temperature was 36.1 °C. The high average temperature occurs in July with a maximum of 23.7 °C, and the low temperature occurs in January with a minimum of -23.0 °C. In the winter, extreme daily minimum temperatures, observed in January and February, can be as low as -39.7 °C and -40.6 °C, respectively.

### 5.2.2 Precipitation

The mean annual precipitation over the same 30-year period (1995 through 2024) was approximately 902 mm, broken down as 722 mm of rain and 263 cm of snow (Table 5-1). The rainiest months are July through

October, averaging approximately 110 mm/mo. Snow generally falls from October to May, with reliable snow cover from November to April. The snowiest months are December and January, with means of 57.3 cm and 49.3 cm, respectively.

**Table 5-1: Distribution of Annual Climate Data for the Period 1981 to 2010**

	Average Temperatures			Average Precipitation		
	Low °C	Mean °C	High °C	Rain mm	Snow cm	Total mm
January	-23.0	-16.9	-10.8	0	49.3	56.3
February	-21.2	-14.1	-7.0	0	39.1	42.9
March	-14.5	-8.0	-1.4	5	35.8	53.5
April	-5.4	0.8	6.8	64	26.1	60.2
May	2.9	9.7	16.5	84	1.5	73.3
June	9.0	15.7	22.4	87	1.0	84.8
July	11.5	17.6	23.7	116	0	96.8
August	9.9	16.1	22.3	109	0	85.3
September	6.2	12.0	17.7	108	0	93.1
October	0.5	4.9	9.4	110	9.9	90.3
November	-7.6	-3.7	0.3	39	47.5	84.3
December	-16.0	-11.1	-6.1	0	57.4	65.0
<b>Total</b>				<b>722</b>	<b>263.4</b>	<b>901.9</b>

Canadian Climate Normals 1981-2010 weather station Val d'Or A, source Environment Canada

### 5.2.3 Evapotranspiration

Evapotranspiration is highest during the summer months and virtually nil during the winter. The annual mean evaporation and evapotranspiration rates are 541 mm and 489 mm, respectively, source Government of Canada.

### 5.2.4 Winds

Winds are generally light. During storm events, sustained winds have been recorded at speeds ranging from 48 km/h to 63 km/h, with gusts up to 124 km/h. Winter storms with snow accumulation of up to 45 cm have been recorded in recent years, although they are rare. Between August and January, a southerly wind is dominant, whereas a north-westerly wind is more common between February and July.

### 5.2.5 Rainfall Intensity-Duration-Frequency

The Rainfall Depth-Duration-Frequency data (IDF) for Val-d'Or airport prepared by Environment Canada are provided in Table 5-2 and Table 5-3. These IDF were developed for the historical period of 1961 through 2017 for duration less than 24 h and 1951 through 2016 for duration between 1 day and 30 days (Table 5-2).

In terms of event occurrence, statistics of rainfall depth indicate a maximum probable rainfall of 332.7 mm in 1 day (Table 5-3). The estimated 2-year return period daily rainfall is 43.6 mm. The 100-year recurrence daily rainfall is 85 mm.

**Table 5-2: Rainfall (mm) Depth-Duration-Frequency at Val-d'Or Airport  
(Period 1961 through 2017)**

Return period (Years)	Duration								
	5 min	10 min	15 min	30 min	1 h	2 h	6 h	12 h	24 h
2	6.9	9.9	11.9	15.2	18.5	22.1	31.1	36.6	41.6
5	8.8	12.2	14.7	19.5	23.7	27.7	38.8	44.3	50.3
10	10.1	13.8	16.6	22.2	27.1	31.4	44	49.4	56.1
25	11.7	15.7	18.9	25.8	31.4	36.1	50.5	55.9	63.4
50	12.9	17.2	20.7	28.4	34.6	39.6	55.3	60.7	68.9
100	14.1	18.6	22.4	31.0	37.7	43.1	60	65.5	74.3

Source: Environment Canada for station of Val-d'Or Airport (ID. 7098600)

**Table 5-3: Rainfall (mm) Depth-Duration-Frequency at Val-d'Or Airport  
(Period 1951 through 2016)**

Return period (Years)	Duration (days)													
	1	2	3	4	5	6	7	8	9	10	15	20	25	30
2	43.6	49.7	55.0	59.6	65.2	69.0	74.0	77.7	81.9	85.3	103.7	123.1	140.7	158.5
5	54.7	60.9	74.5	79.6	86.2	82.0	90.1	93.9	99.7	103.4	124.5	147.2	166.2	183.3
10	-	-	-	-	-	90.6	100.7	104.5	111.4	115.3	138.2	163.2	183.0	199.6
25	71.3	77.6	84.3	89.7	96.8	101.4	114.1	118.0	126.3	130.4	155.5	183.3	204.3	220.3
50	78.2	84.5	91.6	97.1	104.7	109.4	124.1	128.1	137.3	141.6	168.4	198.3	220.1	235.7
100	85.0	91.4	98.8	104.6	112.5	117.4	134.0	138.0	148.2	152.7	181.2	213.1	235.8	250.9
Maximum Probable Rainfall	261.3	272.6	291.6	303.8	322	332.7	400.5	406.5	443.4	453.1	526.0	613.4	657.7	660.5

Source: Environment Canada for station of Val-d'Or Airport (ID. 7098600)

## 5.2.6 Climate Change

Climate change is a risk that needs to be considered in climate assessment for adequate water management. This risk has been evaluated based on available scientific works mainly being the recommendations by the OURANOS consortium for the province of Québec. According to their projection studies, in a scenario of high level of emissions, annual mean temperature and annual mean precipitation are expected to increase by 3.2 °C and 85 mm, respectively in the horizon of 2041 through 2070 (Table 5-4).

**Table 5-4: Projections of Temperature and Precipitation in the Horizon of  
2041 through 2070**

Mean Temperature	Projected variation (°C)	Relative variation in Temperature (%)	Mean Precipitation	Mean Temperature (°C)	Projected variation (%)
Annual	+3.2 (2.0)	260	Annual	+85 (900)	+09.4
Winter	+3.8 (-14.0)	73	Winter	+30 (161)	+18.6

Mean Temperature	Projected variation (°C)	Relative variation in Temperature (%)	Mean Precipitation	Mean Temperature (°C)	Projected variation (%)
Spring	+2.6 (1.4)	285	Spring	+32 (188)	+17.1
Summer	+3.1 (16.3)	119	Summer	-5 (295)	-15.3
Autumn	+2.9 (4.2)	169	Autumn	+25 (261)	+9.6

Variation is relative to the reference period 1981-2010, Source: OURANOS

### 5.3 Local Resources and Infrastructures

Val-d'Or was founded in the 1930s and has a long and rich mining heritage. Val-d'Or, with a current population of approximately 32,752 persons in 2021 (Statistics Canada), is a modern city and one of the largest communities in the Abitibi region of Québec. Both the historic Lamaque and Sigma mines are located within the municipality of Val-d'Or. Historically, these two mines were the largest producers in the area. Val-d'Or has been a mining service center since its inception.

All requirements, including a quality supply of hydro-electric power to support a mining operation are available in Val-d'Or. All infrastructure of the Lamaque Complex is connected to the municipal water system with ample supply for the mining operation. The site is also connected to the municipal sewage system. The operation is connected to high-speed communications through a private provider. Services are further detailed in Section 1.

The operation has a skilled labor force in place. As an active mining region, there is access to experienced mining and technical personnel. Several mining and mineral exploration companies have offices located in the area. Local resources include the following.

- Assayers – Commercial Laboratories
- Civil Construction Contracts
- Diamond Drilling Contractors
- Engineering Consultants
- Freight Forwarding Agencies
- Geology Consultants
- Geophysics Contractors
- Land Surveyors
- Mining Contractors
- Industrial Suppliers – including heavy equipment mechanics, explosives suppliers, machine shops, mechanics, electrical, and instrumentation specialists, electronics, tire service
- Centre National des Mines, is a regional training center with programs in mining vocations; candidates attain certification or technical diplomas providing a quality workforce.

### 5.4 Physiography

The Abitibi region has a typical Canadian Shield-type terrain characterized by low local relief with occasional hills and abundant lakes. The average topographic elevation is approximately 300 meters above sea level (masl) and generally varies less than 100 m. Large areas are dominated by swamps and ponds. Local flora in the area is predominantly spruce, pine, fir, and larch, with a much smaller percentage of deciduous trees, such as birch and poplar.

The mine site is bordered to the north by a large unpopulated wooded area, a portion of which is currently used for tailings and waste rock disposal. A large swamp partially covers parts of the property, while spruce

forest and mixed deciduous and coniferous forest cover the eastern, western, and southern extremities. The elevation difference at the Project rarely exceeds 50 m, except where eskers and glacial deposits are found. The property is at an elevation of about 320 masl.

The historic Lamaque TSF, associated with the past operation of the historic Lamaque mine, covers a large part of the central part of the property. This tailings area is generally populated with herbaceous growth, grasses and areas of small trees planted by previous operators. Spruce forest and mixed deciduous and coniferous forest cover much of the rest of the property. The historic Lamaque TSF is regularly accessed to allow exploration drilling in the northern sector of the Triangle mine as well as the Ormaque and Parallel deposits.

EGQ holds all the surface rights for the Lamaque Complex and has sufficient area to allow for all planned mining and processing operations; storage of future tailings, waste rock, and soil stockpiles to be used in closure activities. Future development will maximize the use of disturbed (brownfield) areas minimizing the need for expansion into undisturbed zones.

## 6 History

The city of Val-d'Or, the "Valley of Gold", has been the center of a highly active mining region for over a century, with significant mineral deposits found throughout the area. Gold has been produced from the historic Sigma and Lamaque Mines since the early 1930s.

Information in the following sections is in large part extracted from the technical report by Poirier et al. (2015a). The history of the Sigma and Lamaque Mines in that report was based largely on the technical report of Lewis et al. (2011). The history has been updated where applicable.

Note historical data pre-1990 may be reported in short tons (2,000 lb), post-1990 all units are in metric tonnes.

### 6.1 History of the Sigma and Lamaque Mines

#### 6.1.1 Lamaque Mines

Gold was first discovered in the Val-d'Or area in 1923 by R.C. Clark on what later became the (historic) Lamaque Property. The coarse gold, hosted in a small quartz vein within a narrow shear zone, was removed in a single blast from the otherwise barren vein. Intensive prospecting by trenching under George Kruse resulted in the discovery of the No.3 vein in 1924. The No.1 vein was also stripped and trenched, but samples collected did not contain significant gold.

In 1924, William Read took an option on R.C. Clark's claims. In November 1928, in partnership with Hector Authier, the company Read-Authier Mines Ltd. (Read-Authier) was formed to acquire property in Bourlamaque Township. In 1929, Read-Authier drilled 19 core holes for a total of 2,143 m to test the veins along strike and at depth. Results were encouraging but inconclusive.

During the late summer of 1932, Major MacMillan optioned Read-Authier's southern claim group for Teck-Hughes Gold Mines Ltd. (Teck-Hughes) and drilled five holes totaling 520 m to validate the previous results. Teck-Hughes subsequently exercised its option and formed Lamaque Gold Mines Ltd. (Lamaque Gold) in December 1932. Lamaque Gold took over the original discovery and several adjoining claims, with Read-Authier retaining a 30% interest in the original claims.

Shaft sinking started in January 1933, followed by lateral development and mill construction. The Lamaque Mine officially opened in March 1933 with an "ore reserve" of 67,580 metric tonnes at 10.62 g/t Au. Development was accelerated in 1933, when U.S. President Franklin D. Roosevelt devalued the US dollar, and the official gold price jumped from US\$20.67 to US\$35.00 an ounce. Sufficient ore was subsequently developed to justify a mill, with construction starting in the summer of 1934. Later, shafts were sunk adjacent to the Main (or No.1) mine, including the No.2, 3, 4, 5, 6, and 7 shafts, and the East and West mine areas were developed.

Processing and gold production commenced at the Lamaque Mine in April 1935, with an initial mill capacity of 250 short tonnes per day. Mill capacity was increased to 500 tons per day by November 1935 and to 1,000 tons per day by December 1937. During World War II, the mill operated at reduced tonnage due to the war effort. The mill capacity was raised to 1,300 tonnes per day in 1951, and in 1953 the capacity increased again to 1,900 tonnes per day. Production was cut back to 1,600 tonnes per day in 1972. Operations ceased in June 1985 and the mill was demolished in 1992.

The No.2 mine was developed in 1950 through 1951, approximately 1,200 m northeast of the main mine area (not to be confused with the No. 2 Shaft located on the Lamaque South Property) and adjacent to the then-active Sigma Mine. Nine levels were developed to a depth of 410.6 m. Production from the No.2 mine

ceased on November 30, 1955, but restarted in 1993 for a short period (production details during the latter period are included in Section 6.1.2).

The Lamaque No.3 mine was developed in 1961 to a depth of 223.7 m and included the No.3, No.4, and No.5 plugs. Production ceased at the No.3 mine in 1967.

From 1952 through 1985, the Lamaque Mine was the largest gold producer in Québec. In 1985, the Lamaque Mine closed.

The principal mining area of the historic Lamaque property was acquired by Placer Dome in November 1993. In 1997, Placer Dome sold the Sigma and Lamaque properties to McWatters Mining Ltd (McWatters). In 1998, a small open pit was developed behind the Lamaque shaft. In 1999 and 2000, limited open pit operations extracted roughly 377,000 tonnes of ore with an average grade of 2.73 g/t Au, which was processed in the Sigma concentrator. No underground development or mining was conducted at Lamaque between 1999 and 2010.

In September 2004, Century Mining Corporation Inc. (Century Mining) purchased the Sigma and Lamaque Mines, and Century Mining re-opened the Mine No. 3 portion of the Lamaque Mine in 2010, which was accessed from a portal from the eastern part of the Sigma open pit. Production was sourced mainly from the narrow sub-horizontal veins (flat veins).

Mining and development used trackless methods, and a low-profile fleet was acquired for mining in the flats. Due to the undulating and thin nature of the flat veins, significant dilution was encountered during stoping. At its production peak, the Lamaque Mine employed 215 persons underground from a total workforce of 385. Total production figures in metric tonnes for the principal mining areas at the Lamaque Mine are shown in Table 6-1.

**Table 6-1: Total 1935-1985 Production Figures for the Lamaque Mine Principal Mining Areas**

Mining Area	Tonnes Milled	Gold Grade (g/t)	Ounces Produced
Main Plug	18,166,848	6.34	3,695,194
East Plug	2,721,397	3.94	343,827
West Plug	1,491,952	4.56	219,014
No. 2 Mine	1,482,775	4.97	237,596
No. 3 Mine	318,560	6.30	58,536
<b>Total Production</b>	<b>24,151,963</b>	<b>5.86</b>	<b>4,554,167</b>

Source Integra Gold Corp.

## 6.1.2 Sigma Mine

In the summer of 1933, Read-Authier sent consulting engineer Herber Bambick to inspect its north claim group. At the time, the area was accessible by water from Amos (93 km) or by sleigh in winter from the CN railway at Barraute (61 km). In October 1933, Bambick discovered a vein while conducting a trenching program from which encouraging results were obtained. This was followed by a diamond drilling program.

Dome Mines Ltd. was invited to examine the property that same year. A recent mining engineering graduate from McGill University, James B. Redpath, checked the sampling results, and a purchase agreement with Read-Authier retaining a 40% interest was negotiated in February 1934. Sigma Mines Ltd. was incorporated in April 1934 and reincorporated in 1937 as Sigma Mines (Québec) Ltd. (Sigma Mine).

By the end of 1934, a mining camp was erected with accommodation for 50 men. A diamond drilling program totaling 3,350 m was completed, revealing a mineralized zone 365 m long and 75 m deep. A second parallel

zone of mineralization was discovered 60 m to the north. An inclined shaft (No.1 shaft) was sunk at 65° on the southern zone to a depth of 80 m. During the first year, 1,632 m of underground development partially opened the two zones, revealing excellent grades and widths.

In 1935, the No.2 vertical shaft was sunk to a depth of 300 m. Exploration identified irregularly distributed gold in seven zones. In 1936, further diamond drilling confirmed the continuity of the mineralization down to 300 m. In June 1936, construction started on a 300 ton per day cyanide plant that could be expanded to 500 tons per day.

The mill was expanded to full capacity the following year, and by 1938 the mill was operating at 650 tons per day. In 1938, the No.2 shaft was deepened to 610 m. The mill capacity continued to expand, reaching 750 tons per day by the late 1939. In 1940, the capacity was increased to 1,000 tons per day, and the plant was operating at 1,100 tons per day by 1942.

During World War II, supply and labour shortages reduced production to 800 tons per day for the duration of the war. During this period, mining of the more labour-intensive high-grade flat veins was suspended in favour of the higher volume, but lower grade, steep veins and dykes. Mining operations returned to pre-war levels by 1948.

In 1952, the sinking of the No.2 shaft reached its final depth of 1,018 m at the 25th level. In 1958, sinking began on the No. 3 shaft from the 22nd level and, by 1960, drifting on the new 30th level indicated that mineralized shoots contained grades comparable to the upper part of the mine. In 1972, the No.3 shaft reached its final depth of 1,817 m below surface, 53 m below the 40th level.

Between August 1972 and May 1974, mill capacity was expanded to 1,460 tons per day, and further expanded to 2,200 tons per day in 1995.

In 1996, Placer Dome Inc. (formerly Dome Mines) began development of the open pit mine at Sigma. In September 1997, Placer Dome sold the Sigma Mine to McWatters. In 1998 and again in 1999, McWatters reduced underground production. In July 1999, McWatters closed the underground mine just 22 months after taking over operations. Although McWatters' underground production records appear to be incomplete, it is estimated that 350,000 metric tonnes were mined from the underground operations under McWatters tenure.

The mill was expanded to 3,000 tpd in 2000 and to 5,000 tpd in 2002. The development of a larger open pit started in November 2002, with ore processing beginning in early 2003. The McWatters open pit operation never reached commercial production (defined as 60% of design capacity for a period of 90 consecutive days). All the McWatters mining operations were shut down in October 2003, and McWatters was placed into bankruptcy.

Century Mining purchased the Sigma and Lamaque Mines in September 2004 and re-started production from the Sigma Mine open pit. The open pit was closed in the fall of 2007 and production commenced from underground. In July 2008, underground production was suspended, and the mine was put on care and maintenance due to economic and financial considerations.

Starting in 2010, while mining around the Mine No. 2 of Lamaque, development and some limited production took place in the Bédard Dyke area. In the North Wall area, a contractor developed access and infrastructure for future vertical stoping areas. These stoping areas were designed to encompass most of the near and medium-term production sources. Access for all three areas was gained via portals and declines developed from within the old Sigma open pit. The mine was shut down in May 2012 and is currently on care and maintenance.

Table 6-2 summarizes the total historical production from the Lamaque and Sigma Mines to the end of May 2012 (Lewis et al., 2011) in metric tonnes.

**Table 6-2: Total Production from the Sigma and Lamaque Mines to End of May 2012**

Mine Operator	Operating Period	Production Figures		
		Tonnes	Grade (g/t)	Au oz.
Lamaque Gold	1935 to 1985	24,151,963	5.9	4,554,167
Sigma Mines*	1937 to 1997	23,898,243	5.8	4,456,420
McWatters	1997 to 2003	3,724,000	2.2	263,405
Century Mining	2004 to 2012	4,138,981	1.7	224,888
<b>Total</b>		<b>55,913,187</b>	<b>5.3</b>	<b>9,498,880</b>

Includes limited production from the Lamaque No. 2 mine area after Placer Dome purchased a portion of the Lamaque Property in 1993. Source Integra Gold Corp.

## 6.2 Lamaque Project Exploration History

Exploration of the Lamaque Project outside of the Sigma and Lamaque Mines prior to Eldorado's acquisition in 2017 was conducted by numerous operators focussing on different portions of the project area. The most significant exploration campaigns during the 1988 to 2017 period are summarized in the following subsections.

### 6.2.1 1988 through 1990: Teck / Tundra

To explore a portion of the historical Lamaque Property, Teck entered into joint venture agreements with Golden Pond Resources Ltd. (Golden Pond) and Tundra Gold Mines Inc. (Tundra) in 1985. The Golden Pond JV, and some of the Tundra JV, covered most of the historical Teck property but excluded the Lamaque Mine area. In addition, the venture included two small claims at the southern limit of the Villemaque Block (claims previously identified as 422883 2 and 421475 2). The Tundra JV also included two non-contiguous parcels. The first parcel of land centred on the No. 5 Plug, and the second parcel centered on the No.4 Plug. Teck was the operator for both the Golden Pond and Tundra JV programs.

In December 1988, Tundra signed an agreement with Teck to acquire a 100% interest in all of Teck's assets at Lamaque. The assets to be acquired included the Lamaque main mine property; all surface structures, including the mill; surface and underground equipment; and Teck's interest in the Tundra, Golden Pond and Roc d'Or Mines agreements. The purchase price for the assets was CAD\$8.0M. Tundra was also required to complete an exploration program and sink an exploration shaft to 304.8 m (1,000 ft) on the No.4 Plug. Preliminary work was initiated to meet the obligations of the agreement, but a downturn in the industry made funding difficult and the 1988 option was never exercised. Teck was left with a 100% interest in the main mine and mill area and eventually optioned and sold those interests to Placer Dome Inc. Subsequently, Tundra's and Golden Pond's interest in the Tundra and Golden Pond JV properties was diluted to 50% due to non-payment of their respective portions of lease rentals, assessment filings, and taxes.

### 6.2.2 2003 through 2017: Integra Gold Corp. - Kalahari

No exploration was conducted on the Tundra and Golden Pond JV properties between 1990 and 2003, when Kalahari Resources Ltd. (Kalahari) and Teck signed an agreement providing Kalahari the option to earn Teck's interest in the JV properties. In 2009, Kalahari purchased the remaining Tundra and Golden Pond interests in the properties through a share swap. Kalahari changed its name to Integra Gold Corp. (Integra) in December 2010 and became the owner of 100% of the then known Lamaque South property.

During the period between January 2003 and December 2014, exploration work was completed on the Lamaque South property, mainly via drilling campaigns. Over 156,248 m of drilling was completed, mainly on various geophysical targets and the following zones: Fortune, Parallel, Triangle, South Triangle, No.6 Vein, No.4 Plug, No.5 Plug, Sigma Vein Extension, Mylamaque and Sixteen Zone. The various drilling programs, and their results, have been discussed in detail in previous NI 43-101 technical reports, all of which were filed by Integra on their SEDAR profile (Risto et al., 2004; Beaugard et al., 2011; 2013; 2014, Poirier et al., 2014; Poirier et al., 2015a; Poirier et al., 2015b).

Drilling during that time was completed by Orbit-Garant Drilling from Val-d'Or, Québec. Analyses were completed by Bourlamaque Assay Laboratory and ALS Canada in Val-d'Or. Exploration work from 2003 to 2008 was supervised by Don Cross and Terrence Coyle, and exploration work from 2009 to the end of 2014 was supervised by Geologica Groupe-Conseil Inc. (Geologica).

Geologica was responsible for exploration guidance, geoscientific compilation, drill hole planning, supervision, logging, and data validation, as well as the geological interpretation of mineralized zones on cross-sections and longitudinal sections. In 2009, Geologica began a re-sampling program of diamond drill core from the 2003–2008 campaigns. Geologica was responsible for establishing QA/QC sampling protocols, including duplicates, blanks and standards, and these protocols were followed for all drilling campaigns. The total number of samples collected in 2009 was 1,654 from 121 holes, and 319 QA/QC samples.

In September 2014, Integra completed the acquisition of the neighbouring Sigma-Lamaque mill and mine complex from Century Mining (Sigma-Lamaque property) and amalgamated it with their Lamaque South property to form the Lamaque project. From January 2015 to December 2016, Integra drilled 490 diamond drill holes, totaling 218,582 m on the Lamaque project (Sigma-Lamaque, Aumaque, Donald, McGregor, and Lamaque South projects). Between January 1 and April 10, 2017, Integra completed an additional 120 holes for 27,015 m on the Lamaque project (Triangle, No.4 Plug, and Lamaque Deep).

In March 2017, Integra released a technical report for the Lamaque project that included a Mineral Resource Estimate (MRE) that incorporated the newly drilled holes (Girard et al., 2017). Details of the Indicated and Inferred Mineral Resources estimated by zone using a 5.00 g/t Au cut-off from the Integra Gold technical report are presented in Table 6-3 and Table 6-4 respectively. The resource estimation and geostatistical study was performed using Isatis (v.15.00) software and involved a 3D block model of 5 m × 5 m × 5 m estimated by co-kriging of top capped grades and indicators as described in Rivoirard et al. (2012).

**Table 6-3: Indicated Mineral Resources, Integra Gold 2017 Technical Report**

Gold Deposit Name	Metric Tonnes	Grade (g/t Au)	Au Ounces
No. 4 Plug (shear veins only)	300,400	8.56	82,630
Fortune	155,000	6.3	31,620
Parallel	426,800	10.29	141,210
Upper Triangle	4,004,700	9.24	1,189,550
No. 6 Vein	201,300	7.90	51,280
Sixteen	41,800	6.90	9,250
<b>Total Indicated</b>	<b>5,130,000</b>	<b>9.13</b>	<b>1,505,540</b>

**Table 6-4: Inferred Mineral Resources Estimate, Integra Gold 2017 Technical Report**

Gold Deposit Name	Metric Tonnes	Grade (g/t Au)	Au Ounces
No. 4 Plug (shear veins only)	579,400	8.59	160,030
Fortune	9,400	6.6	1,990
Parallel	184,100	7.70	45,560
Upper Triangle	2,501,100	7.85	631,200
No. 6 Vein	239,800	7.50	58,080
Sixteen	400	6.40	90
<b>Total Inferred</b>	<b>3,514,200</b>	<b>7.94</b>	<b>896,950</b>

## 6.3 Eldorado

Please note that Eldorado does not consider the following historic Mineral Resource and Mineral Reserve Estimates as the current Mineral Resource and Mineral Reserve Estimate. Current Mineral Resource Estimates are the subject of the economic study detailed in other sections of this report.

### 6.3.1 Eldorado 2018 Technical Report

In July 2017, Eldorado completed the acquisition of Integra, and in March 2018 the company released a technical report for the Lamaque Project that included a new MRE (Triangle, No.4 Plug and Parallel zones; Keogh et al., 2018). The MRE was reported using a 2.5 g/t gold cut-off grade, reflected in the MRE as of December 31, 2017, as presented in Table 6-5.

**Table 6-5: Lamaque Mineral Resource Estimate, as of December 31, 2017**

Deposit Name	Categories	Tonnes (× 1,000)	Grade (g/t Au)	Contained Au (oz × 1,000)
<b>Triangle</b>	Measured	132	10.37	44
	Indicated	3,582	8.84	1,018
	Measured + Indicated	3,714	8.90	1,062
	Inferred	4,648	7.42	1,109
<b>Parallel</b>	Measured	0	0.00	0
	Indicated	221	9.92	70
	Measured + Indicated	221	9.92	70
	Inferred	206	8.70	57
<b>No.4 Plug</b>	Measured	0	0.00	0
	Indicated	762	5.84	143
	Measured + Indicated	762	5.84	143
	Inferred	514	5.56	92
<b>Total Resources</b>	Measured	132	10.40	44
	Indicated	4,565	8.39	1,231
	<b>Measured + Indicated</b>	<b>4,697</b>	<b>8.44</b>	<b>1,275</b>
	<b>Inferred</b>	<b>5,368</b>	<b>7.29</b>	<b>1,258</b>

The 2018 technical report by Eldorado included a MRE for the Triangle deposit, upon which a mining plan and an economic study were made. The MRE was reported using a gold price of US\$1200/oz and an exchange

rate of 1.30 CAD\$:US\$, as well as a cut-off grade of 3.5 g/t gold. Details of the Lamaque Project Mineral Reserves as of December 31, 2017 are included in the 2018 Lamaque Project technical report by Eldorado and are presented in Table 6-6.

**Table 6-6: Lamaque Project Mineral Reserve Estimates, as of December 31, 2017**

Categories	Tonnes (× 1,000)	Grade (g/t Au)	Contained Au (oz × 1,000)
Proven	111	8.78	31
Probable	3,698	7.25	862
<b>Proven + Probable</b>	<b>3,809</b>	<b>7.29</b>	<b>893</b>

The pre-production capital cost from the 2018 study was estimated at CAD\$158M, net of production revenue received from Q2 year 2018 to Q2 year 2019 of the preproduction period (CAD\$104M). The operating costs were estimated in Q1 2018 Canadian dollars with no allowance for escalation, and the overall unit operating cost was CAD\$152.52/t of milled ore. The economic analysis for the Lamaque Project, based on US\$1,300/oz Au, indicated an after-tax net present value (NPV) of US\$211 M, using a discount rate of 5%, and an internal rate of return (IRR) of 35% on an after-tax basis was achieved. Payback of the initial capital was achieved in 3.3 years from the start of production. At the Mineral Reserve metals price of US\$1,200/oz Au, the Lamaque Project showed positive economics. The after-tax IRR was 25.9 % and the NPV is estimated to be US\$150.3 M using a 5% discount rate, with a calculated payback period of 3.9 years.

### 6.3.2 2020 Merger and 2021 Acquisition

On July 1, 2020, Eldorado Gold Québec (EGQ) was created, as the product of the merger of the two related companies, Integra Gold Corporation and Or Intégra (Québec) Inc., bringing together the legacies of the historic Lamaque and Sigma properties into EGQ.

In 2021, EGQ acquired QMX Gold Corporation (QMX). The acquisition of QMX's land position in the Val-d'Or camp provided Eldorado with a significantly increased and consolidated land position in favorable stratigraphy and with excellent exploration potential close to the Lamaque Project.

### 6.3.3 Eldorado 2022 Technical Report

In March 2022, Eldorado released a Technical Report for the Lamaque Project that included a new MRE (Triangle, Parallel, and Ormaque zones; Simoneau et al., 2022). The Mineral Resources were reported using a 3.00 g/t gold cut-off grade for Triangle and Parallel and 3.50 g/t cut-off grade for Ormaque. Details of the Lamaque Mineral Resources estimate as of September 30, 2021, included in the 2022 Lamaque Project technical report by Eldorado are presented in Table 6-7.

**Table 6-7: Lamaque Project Mineral Resource Estimates, as of September 30, 2021**

Deposit Name	Categories	Tonnes (× 1,000)	Grade Au (g/t)	Contained Au (oz × 1,000)
<b>Upper Triangle</b>	Measured	853	9.60	263
	Indicated	5,316	8.51	1,454
	Measured and Indicated	6,169	8.66	1,717
	Inferred	1,792	6.63	382
<b>Lower Triangle</b>	Inferred	6,408	6.89	1420
<b>Parallel</b>	Indicated	221	9.87	70.2
	Inferred	200	8.83	56.7
<b>Ormaque</b>	Inferred	2,223	11.74	839

The 2021 technical report by Eldorado included a MRE for the Lamaque Project (Triangle and Parallel deposits), upon which a mining plan and an economic study were made. The Mineral Reserves were reported using a gold price of US\$1,300/oz and an exchange rate of 1.25 CAD\$:US\$, as well as a cut-off grade of 4.38 g/t gold. Details of the Lamaque Project Mineral Reserves, as of September 30, 2021, included in the 2021 Lamaque Project technical report by Eldorado are presented in Table 6-8.

**Table 6-8: Lamaque Project Mineral Reserve Estimates as of September 30, 2021**

Reserve Zone	Proven			Probable			Total P&P			
	Tonnes	Grade	Ounces	Tonnes	Grade	Ounces	Tonnes	Grade	Ounces	%
C1	40,867	4.96	6,516	120,884	6.38	24,810	161,751	6.02	31,326	2.9%
C2	169,993	6.01	32,831	151,579	6.32	30,782	321,572	6.15	63,613	5.8%
C3	1,006	8.88	287	187,668	6.34	38,242	188,674	6.35	38,529	3.5%
C4	266,554	9.97	85,484	2,666,048	6.92	593,496	2,932,602	7.20	678,980	62.2%
C5	0	0.00	0	758,984	9.10	222,083	758,984	9.10	222,083	20.4%
Parallel	0	0.00	0	269,005	6.08	52,588	269,005	6.08	52,588	4.8%
Surface Inventory	23,227	5.60	4,182	0	0.00	0	23,227	5.60	4,182	0.4%
<b>Total</b>	<b>501,647</b>	<b>8.02</b>	<b>129,300</b>	<b>4,154,167</b>	<b>7.20</b>	<b>962,002</b>	<b>4,655,814</b>	<b>7.29</b>	<b>1,091,302</b>	<b>100%</b>
<b>Total Recovered (96%)</b>			<b>124,128</b>			<b>923,522</b>			<b>1,047,649</b>	

Development of the Lamaque Complex started in 2017 with commercial production beginning April 1, 2019. Table 6-9 shows the total production from pre-production through to the end of 2023.

Table 6-9: Lamaque Complex Production, 2017 to 2023 (Eldorado, 2024)

	Operating Period	Production Figures		
		Tonnes	Grade (g/t)	Oz
Triangle Pre-Production	2017 to March 31, 2019	338 906	5.04	55 006
Triangle Commercial Production	April 1, 2019 to Dec 31, 2023	3 516 324	6.56	742 016
<b>Total</b>		<b>3 852 230</b>	<b>6.43</b>	<b>797 022</b>

## 7 Geological Setting and Mineralization

### 7.1 Regional Geological Setting of the Abitibi Greenstone Belt

The Lamaque Complex is located in the southeastern Abitibi Greenstone Belt of the Archean Superior Province in the Canadian Shield. The regional geological setting described below is summarized from reviews of the geology and ore deposits of the Abitibi Greenstone Belt including Monecke et al. (2017), Poulsen (2017) and Dube and Mercier-Langevin (2020), and references therein. The Abitibi Greenstone Belt has been historically subdivided into northern and southern volcanic zones defined using stratigraphic and structural criteria (Dimroth et al., 1982; Ludden et al., 1986; Chown et al., 1992), based mainly on an allochthonous greenstone belt model (i.e., interpreting the belt as a collage of unrelated fragments). However, more recent U-Pb zircon dating and geological mapping demonstrate that supracrustal rocks in the northern and southern parts of the Abitibi greenstone belt formed during similar times, and ages of plutonic rocks are comparable between both parts of the belt (Davis et al., 2000; Ayer et al., 2002a,b, 2005; Thurston et al., 2008; Goutier et al., 2010). The differences in metamorphic grade and the volume of intrusive rocks between northern and southern regions are best explained by exposure of supracrustal rocks at different crustal levels (Benn and Moyen, 2008).

The Abitibi Greenstone Belt comprises dominantly east-trending folded volcanic and metasedimentary rocks and intervening domes cored by plutonic rocks (Ayer et al., 2002a; Daigneault et al., 2004; Goutier and Melançon, 2007; Figure 71). Folded and faulted volcanic successions typically have a steep dip and commonly young away from major plutonic domes (Thurston et al., 2008). An important feature of the Abitibi Greenstone Belt is the occurrence of regional-scale east-trending ductile-brittle fault zones. These major first-order structures cut across the entire belt dividing the supracrustal rocks and domes into distinct lozenge-shaped domains. The two most important fault zones in the southern Abitibi Greenstone Belt are the Porcupine-Destor fault zone in the north and the Larder Lake-Cadillac fault zone (LLCFZ, also known as the Larder Lake-Cadillac Break or the Cadillac Tectonic Zone) in the south. These fault zones are subvertical (70° to 90°) and dip locally to the north and south. They have highly variable widths, ranging from tens to hundreds of meters and are generally marked by intense ductile-brittle deformation and penetrative fabric development (Poulsen, 2017).

Submarine mafic volcanic rocks dominate underlying approximately 90% of the volcanic rocks in the area. Felsic volcanic rocks account for most of the remainder, with komatiites forming a small but important part of many of the volcanic successions (Monecke et al., 2017). Two unconformable successor basins are recognized and include the widely distributed fine-grained clastic rocks of the early Porcupine-style stratigraphy, followed by Timiskaming-style basins composed of coarser clastic sediments and minor volcanic rocks. The latter are largely proximal to the major faults such as the Porcupine-Destor and Larder Lake-Cadillac fault zones (Ayer et al., 2002a; Goutier and Melançon, 2007).

The Abitibi Greenstone Belt is intruded by numerous syn to late tectonic plutons composed mainly of syenite, gabbro, diorite and granite with lesser lamprophyre and carbonatite dykes. Regional metamorphism varies from greenschist to subgreenschist facies (Jolly, 1978; Powell et al., 1993; Dimroth et al., 1983b; Benn et al., 1994), except adjacent to plutons where the metamorphic grade commonly reaches amphibolite facies (Jolly, 1978).

Regional stratigraphic correlation between the volcanic and sedimentary rocks is hampered by the fact that boundaries between lithostratigraphic units are commonly structural in nature and glacial cover is extensive in many areas. Nonetheless, subdivisions have been defined using mapping and geochronology data from the Ontario Geological Survey and Géologie Québec (Thurston et al., 2008). Six volcanic assemblages are distinguished that formed by submarine volcanic activity between approximately 2750 and 2695 Ma. These

assemblages are referred to, from oldest to youngest, as the Pacaud (2,750 Ma to 2,735 Ma), Deloro (2,734 to 2,724 Ma), Stoughton-Roquemaure (2,723 Ma to 2,720 Ma), Kidd-Munro (2,719 Ma to 2,711 Ma), Tisdale (2,710 Ma to 2,704 Ma), and Blake River (2,704 Ma to 2,695 Ma) assemblages (Figure 7-1). Volcanic rocks older than 2,750 Ma are locally found in the Abitibi Greenstone Belt such as those southwest of Chibougamau (2,795 Ma to 2,759 Ma). The Val-d'Or region is dominated by stratigraphic groups and formations that occur mostly within the Tisdale and Blake River assemblages.

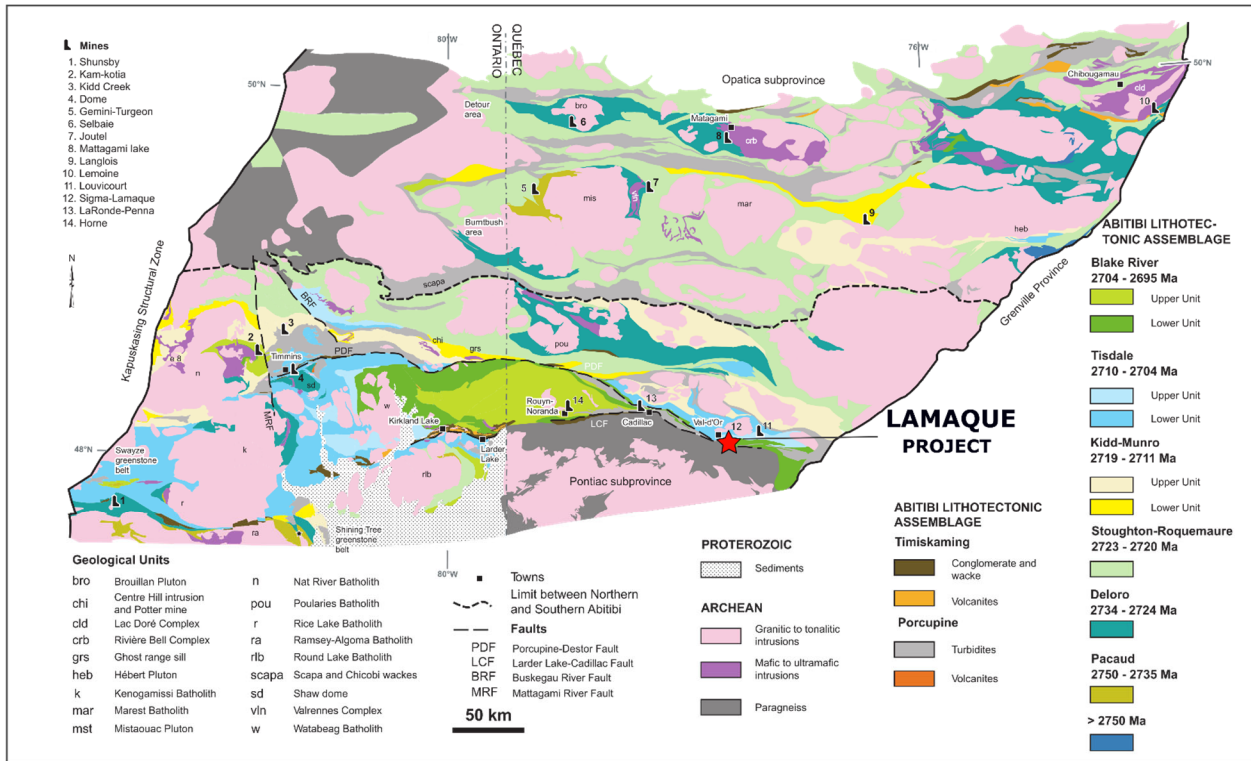

(modified from Ayer et al., 2005; Goutier and Melançon, 2007; Thurston et al., 2008)

Figure 7-1: Geology of the Abitibi Greenstone Belt

## 7.2 District Geology

The Lamaque Complex is in the Val-d'Or mining district in the southeastern part of the Abitibi Greenstone Belt. District-scale geology is described below using information compiled from Gunning and Ambrose (1940), Norman (1947), Latulippe (1976), Dimroth et al. (1982, 1983a, 1983b), Imreh (1976, 1984), Robert (1989), Desrochers et al. (1993), Desrochers and Hubert (1996), Pilote et al. (1997, 1998a, 1998b, 1999, 2000, 2015a, 2015b, 2015c), Scott et al. (2002), Scott (2005) and Poulsen (2017). The LLCFZ is the major fault in the region and defines the contact between the southward-facing volcanic successions of the Malartic Group and the younger folded, but dominantly northward-facing, graywacke-mudstone successions of the Pontiac Group (or Pontiac Subprovince) to the south (Figure 7-2; Poulsen, 2017). The fault is confined to a 200 m-wide high-strain zone containing thin, strongly deformed units including greywacke and mudstone with lenses of conglomerate of the Cadillac Group and felsic to ultramafic rocks of the Piché Group (Robert, 1989). The northern part of the district is dominated by the syn-volcanic Bourlamaque Batholith that intruded the Dubuisson Formation and the base of the Jacola Formation. Several other major intrusive suites include the East Sullivan Pluton, the Bevcon Batholith and the Dunrain and Vicour sills.

## 7.2.1 Stratigraphy

The major volcanic successions in the Val-d'Or mining district belong to the Malartic Group and include, from oldest to youngest, the Jacola, Val-d'Or and Héva Formations. These sequences are southward facing. The Jacola Formation, in the north, is intruded by the Bourlamaque Batholith whilst the Val-d'Or Formation, to the south, is cut by mafic to intermediate plugs and intrusions that host the majority of gold-bearing quartz-tourmaline veins in the district. The Héva Formation occurs between the Val-d'Or Formation and the LLCFZ to the south.

### 7.2.1.1 Jacola Formation

The Jacola Formation ( $2,706 \pm 2$  Ma) comprises, from bottom to top, komatiitic flows, basalts and andesitic volcanoclastic rocks. The sequence may be complete or truncated. Komatiitic lavas are observed in the form of massive flows with local spinifex textures. Basaltic flows are massive, pillowed and sometimes in the form of flow breccias. Magnesian basalts are also present in small amounts and are easily identified by their characteristic pale grey color.

### 7.2.1.2 Val-d'Or Formation

The Val-d'Or Formation ( $2,704 \pm 2$  Ma) is 1 to 3 km thick and comprises submarine volcanoclastic deposits formed by autoclastic and/or pyroclastic flows. These deposits include 1 m to 20 m thick layers of brecciated and pillowed andesite flows with feldspar and hornblende porphyries, intercalated with volcanoclastic beds 5 m to 40 m thick. The pillows exhibit a variety of forms, from strongly amoeboid to lobed, with the latter being 1 m to 10 m long and 0.5 m to 1.5 m high with a vesicularity index of 5% to 40%. The volcanoclastic beds are composed of lapilli and block tuff, and to a lesser extent, fine tuff. The sequence also contains syn-volcanic diorite intrusions, the main example being the C-porphyry that is an important host to gold-bearing quartz-tourmaline veins at Sigma and Ormaque. The C-Porphyry is a local mine term that dates back to the early days of the Sigma Mine and has stuck over the years to describe this important intrusion.

### 7.2.1.3 Héva Formation

The Héva Formation ( $2,702 \pm 2$  Ma) is 2 km to 5 km thick and represents a separate volcanic cycle from that underlying Val-d'Or Formation. It consists of volcanoclastic rocks, pyroclastic rocks, and dykes and sills of gabbroic to dacitic composition. Volcanoclastic rocks are characterized by coarse or fine tuff horizons with millimetre-scale laminations, intruded by gabbro and dacite. Disruptions in the volcanoclastic beds and peperite textures indicate that the dykes and sills were injected into unconsolidated sediments.

### 7.2.1.4 Intrusive Rocks

The stratified rock sequence in the Val-d'Or region is cut and disrupted by several intrusive events (Pilote et al., 2000) including the syn-volcanic Bourlamaque Batholith ( $2,700 \pm 1$ Ma), pre to early tectonic dykes and stocks as the Snowshoe and the East Sullivan suites (dated at  $2,694 \pm 3$  Ma and  $2,684 \pm 1$  Ma, respectively). The late mafic to intermediate plugs ( $2,694$  Ma to  $2,680$  Ma) that intrude the Val-d'Or Formation and host gold-rich quartz-tourmaline veins are described in more detail in Section 7.3.

## 7.2.2 Structural Geology

The LLCFZ is the major first-order structure in the Val-d'Or district. Regionally it has an interpreted strike length of over 500 km and seismic surveys indicate it has a depth extent of between 12 km and 15 km, and locally potentially > 20 km (Dube and Mercier-Langevin, 2020). Gold endowment along the fault exceeds 75 M oz (Monecke et al., 2017). In addition to its strong spatial association with gold deposits, it is also characterized by the presence of ultramafic rocks (e.g., Piché Group) and conglomerates (Timiskaming

assemblage), and is a locus for alkalic-shoshonitic intrusive rocks and carbonate alteration (Poulsen, 2017). Additional major faults in the district include the Manitou shear zone which occupies a central corridor of highly strained metamorphic rocks in the Lamaque Complex area. To the east a similar style fault called the Dunraine shear zone broadly straddles the contact between the Heva Formation and the Val-d'Or Formation (Figure 7-3).

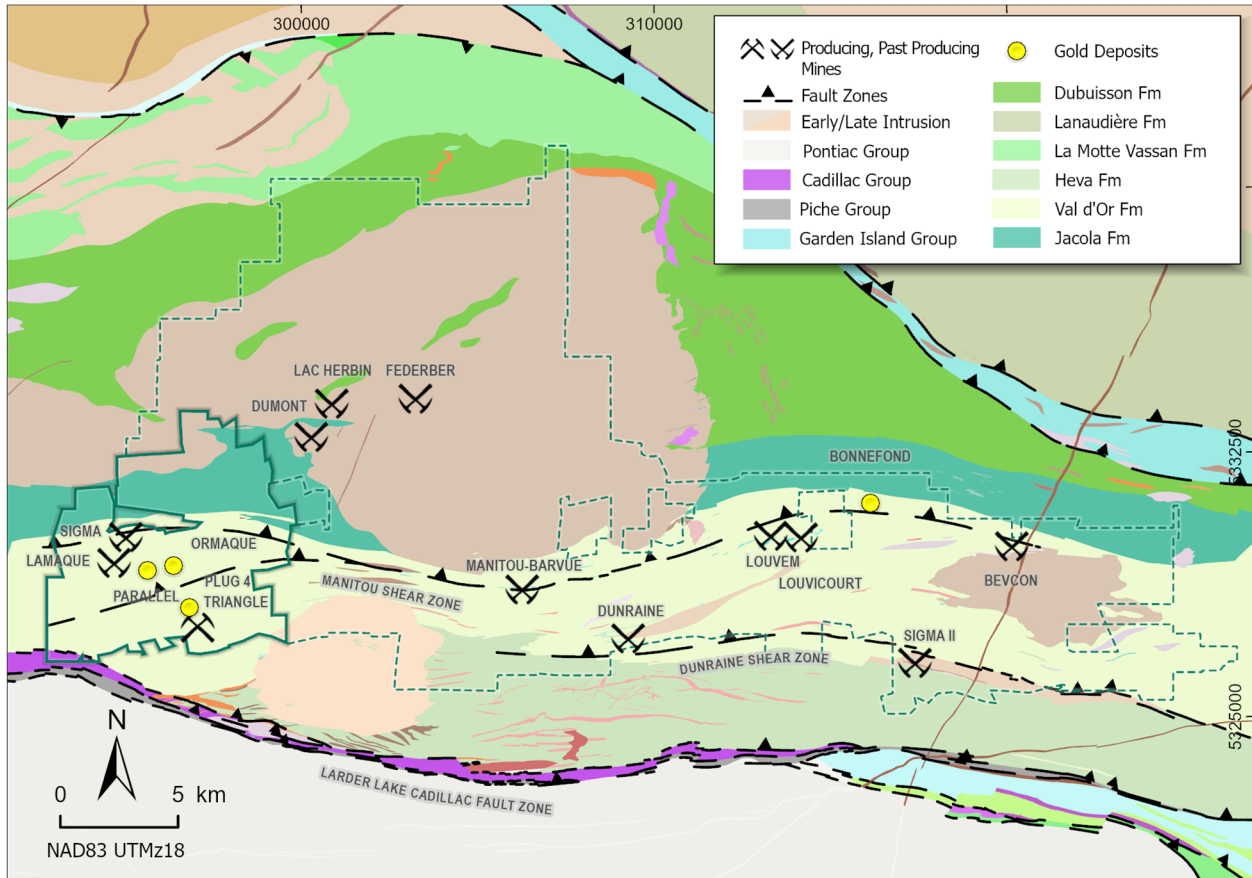

**Figure 7-2: Simplified Geology of Lamaque and Bourlamaque Areas** (based on Sauvé et al., 1993)

Volcanic and volcanoclastic units broadly strike east to west and dip steeply to the north and are locally overturned with a younging direction toward the south (Robert and Brown, 1986a). Regional tilting of the volcanic and volcanoclastic package is the earliest deformation recorded in the district. An early-formed schistosity (S1) is locally preserved and occurs subparallel to bedding (S0) and contains a primary elongation lineation (L1). Near the LLCFZ southwest of the main Val-d'Or mining district, the volcanoclastic stratigraphy is tightly folded with a locally developed axial planar schistosity oriented roughly east to west and subvertical. The axes of these folds are parallel to the L1 lineation. The main penetrative fabric is a regionally extensive S2 foliation that strikes broadly east to west with a moderate to steep dip to the north, representing a major broad-scale north to south shortening event. Peak greenschist-facies metamorphism corresponds to D3 deformation (~ 2,665 - 2,640 Ma; Dube and Mercier-Langevin, 2020).

## 7.3 Local Geological Setting and Mineralization

### 7.3.1 Geology

The Lamaque Complex area is underlain by volcanic rocks of the Malartic Group and mafic to intermediate intrusions that range in age from syn-volcanic (2,702 to 2,705 Ma) to syn to late tectonic (2,695 to 2,680 Ma; Figure 7-3) and rare diabase dikes of Proterozoic age. The stratified units young to the south with the Jacola Formation in the northern portion of the Project area overlain successively by the Val-d'Or Formation and the Héva Formation. The Val-d'Or Formation covers most of the Lamaque Complex area and is characterized by interstratified massive to pillowed lavas and volcanoclastic rocks of andesitic-basalt to rhyolitic composition. According to Scott et al. (2002) and based on yttrium-zirconium ratios, the volcanic rocks of the lower Val-d'Or Formation are tholeiitic to transitional, while the upper levels are tholeiitic to calc-alkalic.

Because of their intimate spatial association with the known gold deposits the intermediate to mafic intrusive rocks that intrude the Val-d'Or Formation are particularly important. The oldest intrusion on the property is the C-Porphyry (2,703.7 ± 2.5 Ma; Wong et al., 1991). Field relationships and age data support a syn-volcanic timing. New geological mapping, drilling and 3D modelling suggests the C-Porphyry forms a series of sill-like bodies elongated in an east-west direction (Figure 7-3). Commonly contacts with the volcanic host rocks are diffuse and gradational, however, they are important competency contrast sites for gold mineralization. The intrusion is dioritic in composition and is a light to medium grey, but with textures ranging from a finely crystalline homogeneous rock with a micro-porphyritic texture containing lath or tabular shaped feldspar crystals up to 4 mm long to a medium crystalline crowded porphyritic texture.

Several syn to late tectonic intrusions are recognized in the Lamaque Complex area and were emplaced between ~ 2,695 and 2,680 Ma. The oldest intrusions in this suite are feldspar porphyry dikes and the mafic Plug No. 4 intrusion (2694 ± 2.2 Ma and 2693.2 ± 4.7 Ma respectively; Wong et al., 1991; Dube, 2018). Plug No. 4 hosts gold-bearing quartz stockwork veins immediately north of the Triangle mine. It measures about 100 m in diameter and has been intercepted in drillholes to a depth of 1,300 m. It consists of fine to medium-grained gabbro with a strong magnetic signature. The host to gold mineralization at the historic Lamaque mine is the Main Plug and has an age of 2,685 ± 3 Ma (Jemielita et al., 1989). The Main Plug is a steep north-northeast plunging chimney-like intrusive body, which measures roughly 245 m by 115 m in diameter. It displays concentric compositional zonation, with an outer rim dominantly of dioritic composition grading inwards into a porphyritic quartz-diorite phase and a granodiorite core. Satellite intrusions of similar composition, namely the West and East Plugs, also host gold mineralization at the historic Lamaque Mine.

The Triangle Plug is host to the gold-bearing quartz-tourmaline veins in the Triangle Deposit and is a cylindrical-shaped, steeply north-plunging porphyritic diorite. It consists of an early melanocratic diorite and a younger leucocratic phase containing less than 20% mafic minerals. Several intrusive phases have been dated at the Triangle deposit (Dube, 2018). U-Pb dating of magmatic zircons constrain the age of the leucocratic phase to 2684 ± 1.2 Ma and the melanocratic phase to 2680.1 ± 4.0 Ma (Dube, 2018). In addition, the intermediate North Dyke was dated at 2685 ± 0.9 Ma. Timing of these phases overlap; however, field relationships indicate the North Dyke was the earliest intrusion and was cut by the Triangle Plug. Numerous other porphyritic dykes and sills are common in the project area, and they vary from concordant or subparallel to stratigraphy to cross cutting and are felsic to intermediate composition.

First, second and third order structures are recognized throughout the Lamaque Complex area (Figure 7-3). As previously described, the LLCFZ is the major regional crustal-scale structure that juxtaposes different lithotectonic units to the south of the property and exhibits a protracted deformation history active from D1 (Poulsen, 2017). Second order structures are large-scale (2 km to > 5 km) shear zones such as the Manitou Shear Zone and are characterized by an intense shear fabric that developed during D2. Third order

structures are discrete, smaller scale faults that typically have strike lengths of <1 km to 2 km and control the development of gold-bearing quartz-tourmaline veins. Most of these faults have a steep southerly dip with a reverse sense of movement that reflect north-south compression during the mineralizing event (D3; see discussion below). The mineralogy of the shear zones, related veins and alteration consist dominantly of chlorite, muscovite, carbonate, albite, quartz, tourmaline and pyrite (Robert and Brown, 1986 a, b; Dube, 2018). The youngest faulting event manifests as dextral strike-slip faults and is post-mineral.

The absolute timing of metamorphism, magmatism and mineralization is subject to extensive debate (Jemielita et al., 1990; Robert, 1990; Wong et al., 1991; Cowan, 2020; Dube and Mercier-Langevin, 2020). The volcanic sequence including the syn-volcanic C-porphyry contain a S2 penetrative cleavage which is particularly well-developed within the various strands of the Manitou Shear Zone. The younger mafic to intermediate intrusions do not display this penetrative foliation but locally develop shear fabrics proximal to third order fault zones. Wong et al. (1991) and Robert et al. (1983) also document the late intrusions as cutting the main regional folding and deformation event. Wong et al. (1991) directly dated the peak metamorphic event at  $2684 \pm 7$  Ma through U-Pb dating of rutile in the Colombière rhyolite which is located 13 km east of the Sigma mine. Peak metamorphism therefore coincides broadly with the emplacement of the younger plugs and dikes. This is supported by the fact that the assemblages in the late intrusions are greenschist facies minerals (chlorite, muscovite, albite, carbonate, epidote and actinolite; Robert and Brown, 1986 a,b; Dube, 2018). Robert and Brown (1986 a,b) further identified a horizontal isograd between epidote-chlorite-white mica and epidote-chlorite-biotite at a depth of ~ 800 m which they interpreted as the transition between lower and upper greenschist facies metamorphism. Spectral data interpretation supports the widespread occurrence of these minerals with biotite and amphibole more localized in their distribution.

Dube and Mercier-Langevin (2020) discuss in detail the controversy surrounding the absolute age of mineralization in Val-d'Or and the wider Abitibi. The third-order structures that host gold-rich quartz-tourmaline veins clearly post-date the younger intrusions (~ 2,680 Ma), peak metamorphism ( $2684 \pm 7$  Ma) and the earlier D2 deformation. The geometry and kinematics of the auriferous vein networks in the Val-d'Or district is compatible with the regional D3 strain (Robert, 1990; Dube and Gosselin, 2007). Dube and Mercier-Langevin (2020) suggest the minimum age of D3 is ~ 2,640 Ma based on the age of the Preissac-La Corne two-mica monzogranite that post-dates D3. Molybdenite associated with gold mineralization at the nearby Canadian Malartic mine yields Re-Os age of  $2,670 \pm 10$  Ma (De Souza et al., 2017) which is compatible with D3 timing in the Val-d'Or district. However, hydrothermal rutile from an alteration halo around the veins in andesite at Sigma has a much younger U-Pb age of  $2599 \pm 9$  Ma (Wong et al., 1991). Similarly U-Pb ages of  $2625 \pm 7$  Ma have been obtained from hydrothermal titanite and rutile at the nearby Camflo mine (Jemielita et al., 1990). Dube and Mercier-Langevin (2020) argue that these younger ages are incompatible with field relationships and likely reflect thermal resetting.

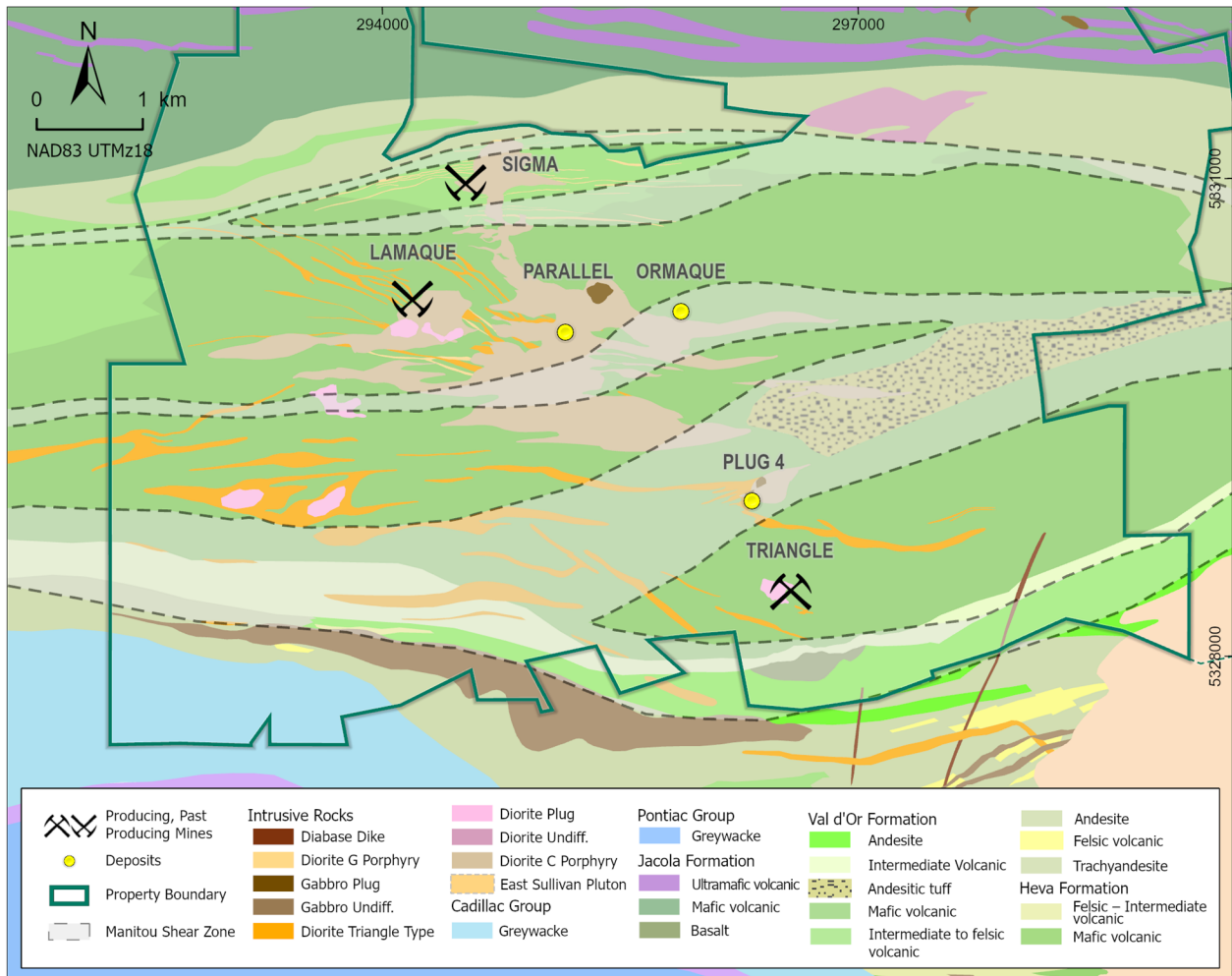
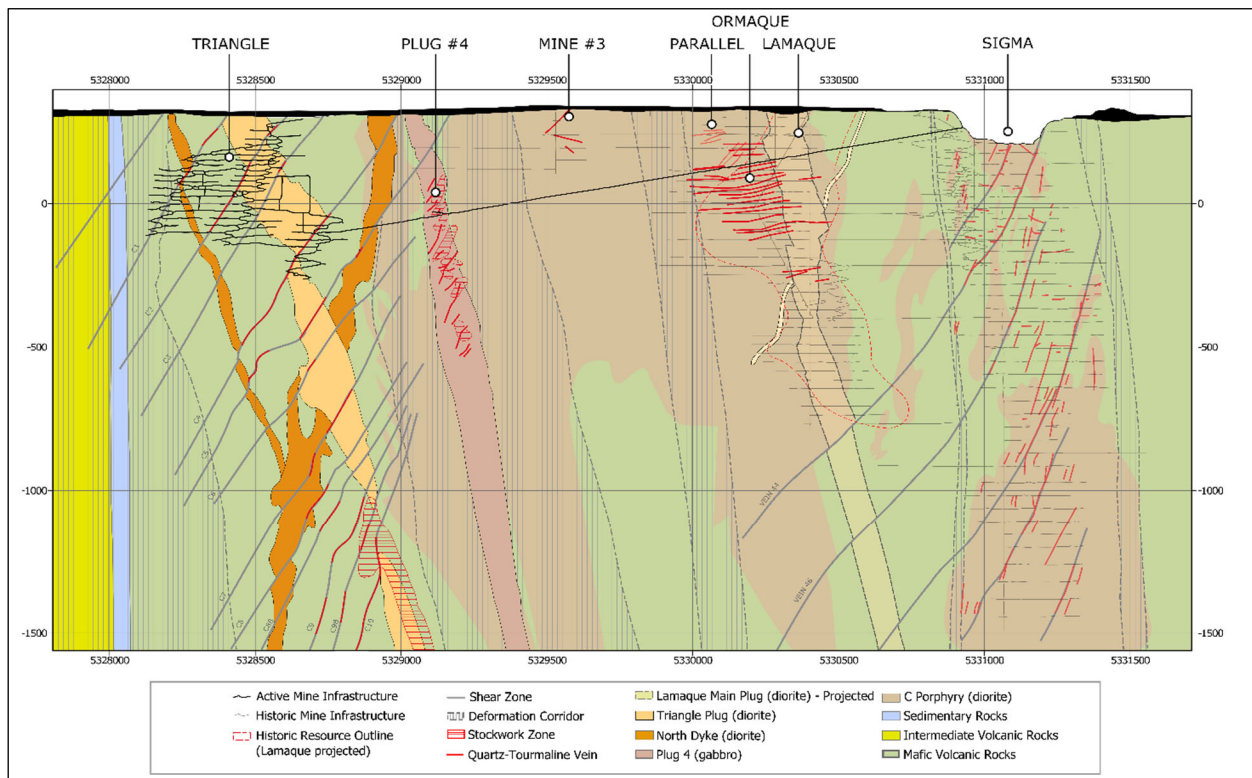

Figure 7-3: Geology of the Lamaque Complex Area (Eldorado 2024)

### 7.3.2 Gold Mineralization

The majority of gold in the Lamaque Complex area is hosted by quartz-tourmaline-carbonate veins, which vary from shear hosted and/or extensional vein systems to complex stockworks zones. The historical mines at Sigma and Lamaque together produced over 9.5 Moz of gold. The geology of these mines is summarized below due to their proximity, economic importance, and geological similarity to the more recently discovered gold deposits on the property. The section then focuses on the geology of Triangle, Plug No. 4, Parallel, and Ormaque deposits. The descriptions of the deposit geology are drawn from widely published papers and reports including Beauregard et al. (2011), Dubé (2018), Robert (1983), Robert and Brown (1986a, 1986b), Robert et al. (1995), Garofalo (2000), Gaboury et al. (2001), Olivo et al. (2006), Perrault et al. (1984), Karvinen (1985) and McKinley et al. (2021).



**Figure 7-4: Composite Section Looking West through the Triangle, Plug No. 4, Ormaque, Parallel, Lamaque and Sigma Deposits (Eldorado 2022)**

### 7.3.2.1 Sigma Mine (historic)

Three main lithologic units are identified in the Sigma mine including volcanic rocks of the Val d'Or formation, C-porphyry diorite and feldspar porphyry dykes (Figure 7-3 and Figure 7-4). The volcanic rocks include various tuffaceous rocks and associated pillowed and massive andesite lava flows. These rocks strike east-west and dip steeply to the north. The C-porphyry is a plagioclase-phyric diorite of subvolcanic origin that intrudes the lavas. The diorite forms a sill-like body and is cut by younger feldspar porphyry dykes ("G dykes" according to the mine nomenclature). These dykes strike approximately east-west and dip steeply to the south, with thicknesses of individual dykes ranges from a few centimeters to about 10 m, and averages 3 m. Numerous third-order shear zones are the dominant structural features of the deposit. The shear zones are up to 6 m wide, strike east-west, and dip moderately to steeply to the south ( $50^{\circ}$  to  $90^{\circ}$ ). They mostly have a reverse sense of movement and overprint the S2 regional schistosity. The east-west striking and subvertical S2 fabric overprints the C-porphyry and volcanic rocks and is particularly well developed in strands of the Northern Manitou Shear Zone that occurs on the north and south flanks of the mine (Figure 7-3).

Auriferous veins at the Sigma Mine consist of quartz and tourmaline with lesser carbonates, muscovite, pyrite, scheelite, chlorite and chalcopyrite (Robert and Brown, 1986a,b). There are four types of veins that can be distinguished based on their host rock associations and geometries: (1) steeply to moderately dipping fault-fill veins within shear zones; (2) subhorizontal extensional veins; (3) arrays of subhorizontal extensional veins hosted within the feldspar porphyry dykes, referred to as dyke stringers; and (4) moderately north-dipping extensional-shear veins, referred to as the North Dipper veins.

### 7.3.2.2 Lamaque Mine (historic)

The volcanic sequence within the Lamaque Mine strikes east-west and dips steeply south. It consists of andesitic basalt lapilli tuffs mixed with lesser andesite flows, flow breccia and mafic lavas. The oldest intrusive rocks at Lamaque are porphyritic diorite dykes and stocks considered equivalent to the C-Porphyry at the Sigma Mine. Numerous chimney or plug-shaped intrusions varying from mafic to felsic compositions occur at Lamaque, with the Main Plug being the most productive host rock. The Main Plug is roughly elliptical (250 m east-west by 100 m north-south), plunges northeast at 70° and has been traced to a depth of 1,800 m. The core of the Main Plug is a medium to fine grained, dark grey, homogeneous tonalite-diorite, which grades outward to quartz diorite and finally diorite. The West and East Plugs have the same composition as the Main Plug, but the West Plug is coarser grained. Many types of porphyry dykes have been identified based on characteristics such as mineral composition and grain size. Most are lithologically similar to the feldspar porphyry “G dykes” at the Sigma Mine, with the exception of quartz diorite porphyry that is unique to the Main Plug area. All of those dykes are older than the intermediate Main Plug intrusion.

Gold mineralization at Lamaque consists of quartz-tourmaline-carbonate-pyrite veins, stringers and stockworks. These gold-bearing veins occur within all rock types but are most abundant in late intrusions. Roughly 85% of the gold mined historically at Lamaque was from veins hosted by the Main Plug. The quartz-tourmaline-carbonate veins, as at Sigma, are associated with brittle-ductile reverse shear zones, and occur in multiple orientations and styles. The veins were classified into three main types namely shear veins, flat veins, and stringer veins (Karvinen, 1985). The shear veins are generally thick (up to 10 m) and have strike lengths of over 500 m. They are best developed in the volcanic rocks away from the plugs in the upper parts of the mine. Typical thicknesses of flat veins are less than 0.5 m but these also extend for hundreds of meters in strike. They dip gently (10 to 20°) to the west and intersect shear veins at 75 to 85°. Stringer veins are essentially stockwork veins and veinlets found predominantly in the two productive plugs and in several zones these veins were so numerous that bulk mining was possible. These stockwork zones were very prolific at the Lamaque Mine and produced most of the ore. They were developed usually near the intersection of sub-vertical south dipping shear zones with the intrusion. The resulting geometry created large zones of gold bearing veins and veinlets that could be as large as the intrusion itself and therefore were very economic to extract.

### 7.3.2.3 Triangle Mine

The Triangle deposit was discovered in 2011 by drilling an isolated circular magnetic high feature south of the Sigma mine and Lamaque mine. The magnetic feature is now interpreted to correspond to the contact aureole and/or altered zone within the mafic volcanoclastic rocks surrounding a non-magnetic porphyritic diorite intrusion (Triangle Plug) and extends over a subcircular area roughly 800 m in diameter.

The volcanoclastic rocks in the area of the Triangle deposit consist of feldspar phenocryst rich (fragments and matrix) lapilli-block tuffs of andesitic to basalt composition. The size of the blocks can reach 70 cm. The texture of the coarse-grained matrix is generally massive; however, grading is present locally. Fine grained beds are less common and turbidite facies have not been observed. Rare thin concordant lava flows, as well as complex and irregular subvolcanic intrusions, are intercalated within the volcanoclastic sequence. The tuffs lack penetrative schistosity but contain a stretching lineation and a weak flattening and alignment of fragments. The strong competency of the rocks surrounding the Triangle Plug coincides with a mineralogical change from Fe-Mg chlorite and paragonitic muscovite in the volcanic rocks to a Mg-dominant chlorite and muscovite with pervasive albite-quartz-epidote (magnetite-pyrite) in and around the intrusion.

The Triangle Plug is a chimney-shaped feldspar porphyritic diorite very similar in composition to the Main Plug at the Lamaque deposit. The Triangle Plug is composed of two different facies of the porphyritic diorite. A mafic facies composed of 25-40% hornblende pseudomorphs (now chlorite-altered) with minor chloritized

biotite in the matrix, and a more felsic facies comprises less than 25% mafic minerals in the matrix. For both facies, the rock contains 10-30% medium-grained zoned feldspar phenocrysts. The Triangle Plug plunges at roughly 70° towards the north-northeast. At a depth of around 700 m below surface, the Triangle Plug cuts a large dyke called the North Dyke, which extends east-west for a distance of over 4 km and dips vertically. The North Dyke is also a feldspar porphyritic diorite that shares similarities to both facies of the Triangle Plug. The dyke has been traced to a depth of over 1,800 m below surface.

Gold mineralization in the Triangle deposit occurs primarily within quartz-tourmaline-carbonate-pyrite veins in the Triangle Plug and adjacent massive mafic lapilli-blocks tuffs. The veins are localized in a series of shear zones and fractures that cut both units. The thickest and most continuous veins have an east-west strike and developed within ductile-brittle reverse shear zones that dip 50° to 70° to the south. They are classified as C-veins (shear veins) and at least thirteen discrete C-veins (C1 to C11 and C8b and C9b) have been identified to a depth of greater than 1,500 m. Smaller extensional shear veins form splays to the C-veins and dip 20° to 45° south and are commonly associated with sub-horizontal extension veins. The bulk of the gold occurs within the quartz veins, but lower concentrations of gold also occur in the strong muscovite-carbonate-pyrite alteration selvages. At the base of lower Triangle deposit, within the lower faulted portion of the Triangle Plug, an intense stockwork vein system is present between the main shear veins. These consist mainly of flat-lying extensional quartz-tourmaline-carbonate veins with associated silica-albite-sericite-tourmaline alteration. These veins are gold bearing, but usually lower grade.

#### 7.3.2.4 Plug No. 4 Deposit

The Plug No. 4 deposit is located 550 m north of the Triangle deposit and 1 km southwest of the historical No. 3 Mine shaft, to which it is connected by drifts on the 450 and 700 levels. Plug No. 4 is a fine- to medium-grained magnetic gabbro intrusion measuring roughly 100 to 150 m in diameter. It is enveloped by an older syn-volcanic diorite and diorite breccia similar to the C-porphyry. These intrusions are cut to the west by a fine-grained porphyritic felsic diorite dyke which extends northwest towards the No. 3 Mine area. Gold mineralization at Plug No. 4 is restricted to the gabbro intrusion.

A series of east-west striking reverse shear zones dipping between 45° and 75° to the south cut all units at Plug No. 4. The shear zones are spaced roughly 25 m to 50 m apart and have been identified to depths of more than 1000 m from surface in the gabbro. Gold mineralization at the Plug No. 4 deposit occurs in quartz-tourmaline-carbonate-pyrite veins. These veins have both laminated and breccia textures and are associated with, and controlled by, the major reverse shear zones. Low angle extensional shear veins (dipping 35° to 45° south) occur adjacent to these shear veins but have limited strike extent. Sub-horizontal extension veins are much more abundant in Plug No. 4 than at Triangle and occur in vein arrays or clusters in the gabbro intrusion with dimensions measuring up to tens of metres. The thickness of individual veins can vary from 1 mm to 1.25 m, but most are between 5 cm to 10 cm. These vein clusters can carry significant gold, but grades are generally erratic. Where vein intensities are greatest average gold grades are ~ 3-4 g/t Au over intervals of 20-30 m. The flat extension vein arrays at Plug No. 4 are spatially associated with the reverse shear zones, occurring most abundantly in zones that extend up to 15 m into the hanging wall and footwall of the shear zones. Commonly, the spacing between veins increases away from the shear zones, while vein thickness, wall rock alteration, tourmaline and pyrite abundance and gold content diminish.

#### 7.3.2.5 Parallel Deposit

The Parallel deposit is located 650 m northwest of the No. 3 Mine and 900 m east-southeast of Lamaque Mine main shaft. Gold mineralization at the Parallel deposit is hosted within fine- to medium-grained C-porphyry diorite. The diorite is medium greenish-gray and contains 1 to 5% disseminated pyrite commonly in a chlorite-silica pervasive alteration. The ore zones at the Parallel deposit occur as sub-horizontal extension

veins at shallow depths (70 m to 200 m) and as east-west striking shear veins dipping approximately 30° south at deeper levels. The mineralized veins consist of quartz and carbonate with lesser amounts of tourmaline, chlorite, and sericite. Fine pyrite within the vein commonly amounts to 1-3% and rarely up to 5%. Traces of chalcopyrite occur locally. In wider veins, pyrite and gold are typically confined to vein margins and/or vein contacts, especially in veins composed mainly of quartz and carbonate. The sub-horizontal veins are laterally extensive (up to 300 m) and occur in en-echelon arrays that exhibit pinch and swell geometries. Adjacent wall rocks contain carbonate-albite-muscovite-pyrite alteration. In general, the veins form stacked sets which are 10 m to 25 m thick and contain up to 8 individual veins. Shear veins also occur in clusters. Typically, up to four en-echelon south dipping veins occur within a 75 m wide vertical corridor that cuts across the porphyritic diorite. The shear veins most commonly range in width from 15 cm and 1.5 m but can be up to 2.6 m thick locally.

### 7.3.2.6 Ormaque Deposit

The Ormaque deposit is located immediately east of the Parallel deposit, approximately midway between the historic Sigma mine and the currently producing Triangle mine (Figure 7-4). The Ormaque vein system occurs within the C-porphyry at the contact with volcanoclastic rocks to the north. Gold mineralization occurs dominantly in gently south-dipping quartz-tourmaline-carbonate extension veins and localized breccia zones. A characteristic feature of the Ormaque deposit is the intense tourmaline-pyrite alteration selvages that surround the extension veins. The alteration halos are well mineralized and commonly contain visible gold. More broadly the vein system is surrounded by an Fe-chlorite alteration footprint (Mckinley et al., 2021). Individual extension veins have widths ranging from several cm up to 2 m and have east-west strike lengths of up to 650 m. The veins form vertically stacked clusters from a depth of about 150 m to at least 800 m below surface. Moderately south-dipping shear or hybrid shear-extension veins locally interconnect some extension vein segments. Ductile to semi-brittle, east-west striking and steeply north-dipping shear zones anastomose through the C-porphyry and may represent pre-existing and/or early syn-mineral structures that controlled vein formation and higher-grade domains.

## 8 Deposit Types

### 8.1 Orogenic Gold Deposits

Classic case studies of gold deposits in the Val d'Or district have contributed to the definition of the orogenic gold deposit type (Robert and Brown, 1986a,b; Robert and Kelly, 1987; Robert et al., 1983; Roberts, 1987; Sibson et al., 1988). The following features of the gold deposits in the Val D'Or region are consistent with the orogenic gold model (Goldfarb et al., 2005; Dubé and Gosselin, 2007; Dube and Mercier-Langevin, 2020).

**Structural Setting:** Orogenic gold deposits are typically distributed along first-order compressional to transpressional crustal-scale fault zones that mark the convergent margins between major lithological and/or tectonic boundaries (e.g., Larder Lake–Cadillac Fault Zone). These major regional structures display evidence for being long-lived faults with multiple episodes of movement and deformation. For example, the Larder Lake-Cadillac fault is closely associated with the Timiskaming conglomerate and likely controlled sedimentary deposition, as well as acting as a focus for later deformation, magmatic and hydrothermal activity (Poulsen, 2017).

Although these major or first-order faults are interpreted as primary hydrothermal pathways (Eisenlohr et al., 1989; Colvine, 1989; McCuaig and Kerrich, 1998; Kerrich et al., 2000; Neumayr and Hagemann, 2002; Kolb et al., 2004; Dubé and Gosselin, 2007), only a few significant gold deposits are hosted within the major faults. Examples in the Abitibi include the McWatters mine, Lapa mine and the Orenada deposit (Morin et al., 1993; Robert, 1989; Neumayr et al., 2000; 2007; Simard et al., 2013). The majority of orogenic gold deposits are hosted in second- and third-order shear zones, typically within a few kilometers of the principal shear zone, and display evidence of forming in ductile to brittle–ductile environments (Hodgson, 1993; Robert and Poulsen, 2001). In the Val-d'Or area, the gold deposits are associated with subsidiary shear zones north of the Larder Lake-Cadillac fault that formed syn- to late D2 (Robert, 1990; or regional D3 of Dube and Mercier-Langevin, 2020).

**Metamorphism:** Most major orogenic gold systems formed in and around the brittle-ductile transition which typically coincides with greenschist facies metamorphic conditions (2 to 3 kbar and 300 to 400°C). Robert and Brown (1986) document the orogenic veins at Sigma as having formed syn- to late peak greenschist facies metamorphism. They describe volcanic rocks and intrusions as having the same mineralogy including plagioclase, quartz, chlorite, epidote, clinozoisite, and white mica or biotite consistent with greenschist facies conditions. They further identified a horizontal isograd between epidote-chlorite-white mica and epidote-chlorite-biotite at a depth of ~ 800 m which they interpreted as the transition between lower and upper greenschist facies metamorphism. Orogenic gold deposits that are hosted in higher grade metamorphic rocks commonly show evidence for the metamorphism post-dating the gold event (Tomkins et al. 2004; Tomkins and Mavrogenes, 2001; Phillips and Powell, 2009).

**Host Rocks:** Although most orogenic gold deposits in Archean terranes are hosted in greenstone belts, in detail the immediate host rocks are variable and focus mineralization as a function of competency contrast and/or chemical trap (Goldfarb et al., 2005). The latter include banded iron formations, iron-rich basalts, and carbon-rich rocks, however, in the Lamaque Project area competency contrasts are the most important localizing host rock control (Robert and Brown, 1986a,b; Robert and Kelly, 1987; Sibson et al., 1988; McKinley et al., 2021). At Lamaque and Triangle the intersection of shear zones with late diorite to granodiorite plugs host the main gold-bearing veins, whereas at Sigma and Ormaque a syn-volcanic diorite (the C-porphyry) hosts mineralization at the sheared contact with the surrounding volcanoclastic rocks.

**Vein Mineralogy and Texture:** Orogenic gold deposits develop in response to shear failure, extensional failure and/or hybrid extensional shear failure (Cox, 2020). The former form shear veins that are commonly

vertical to steeply dipping, have laminated to foliated internal vein textures and irregular, deformed margins that are sub-parallel to parallel to the host shear zones. In extensional failure, extension veins develop which have shallow dips, parallel planar walls, and open-space infill textures. They commonly form stacked vein arrays or isolated tabular veins. They have a complex relationship with shear veins and shear zones. In some cases, they propagate off shear veins and/or nucleate on earlier formed shear zones. In other instances, they may cut shear veins and shear zones but commonly become deformed during progressive brittle-ductile deformation. Extension veins may also develop strong stockworks in more competent lithologies.

In the vicinity of the Lamaque Complex, both shear veins and extension veins are widely recognized, and their identification is important to constrain vein geometries and ore shoots. Robert and Brown (1984, 1986a,b) described in detail two main vein types from Sigma, assigning them as vertical (shear) and flat (extension) veins. In the Triangle deposits, the main C vein structures are steeply dipping shear veins and host the bulk of the resource, whereas in the Ormaque deposit gently dipping extension veins contain most of the ore.

**Alteration and Fluid Characteristics:** Orogenic gold deposits are typically characterized by carbonate, white mica, albite, chlorite, and pyrite alteration reflecting the pressure, temperature, and composition of the hydrothermal fluids from which they formed (Goldfarb et al., 2005). Fluid inclusion studies have demonstrated that gold was deposited from low salinity (< 5 wt. % NaCl equiv.), moderate temperature (300 °C to 400 °C) aqueous-carbonic fluids. Robert and Brown (1986) documented a zoned alteration at Sigma comprising a cryptic outer alteration halo of chlorite, white mica and carbonate, and an inner zone of moderate to strong carbonate-white mica alteration with an inner subzone of carbonate and albite. Disseminated tourmaline and pyrite commonly occurs in greater abundance near the vein margins. Similar alteration style and mineralogy are present at Triangle whereas in the Ormaque deposit alteration is characterized by a broad Fe-chlorite footprint and intense, texturally destructive, tourmaline and pyrite wall rock alteration immediately adjacent to the extension veins that also commonly contains visible gold (Mckinley et al., 2021). Fluid inclusion studies at Sigma by Robert and Kelly (1987) identified low salinity aqueous carbonic inclusions associated with gold-bearing quartz veins that formed at minimum temperatures of 285 °C to 395 °C. Precipitation of gold was likely due to fluid unmixing.

## 9 Exploration

### 9.1 Property Scale Exploration

Exploration in the Val-d'Or area dates to the original discovery of gold on the property in 1923. Documented historical production of 9.5 million ounces of gold, mainly from the Sigma and Lamaque Mines, has motivated numerous periods of exploration activity conducted by several companies. The most recent phase of exploration began in 2017, shortly after Eldorado purchased the Project through the acquisition of Integra. During this period, in addition to extensive drilling at Triangle, exploration drilling programs have been conducted at the Plug No 4 and Parallel deposits, as well as the Aumaque, South Gabbro, Lamaque Deep, Vein No.6, P5 Gap, Sigma East Extension, Ormaque, Sector Nord and other targets. Underground development at the Triangle mine has provided platforms for resource conversion and exploration drilling programs. In January 2020, Eldorado announced the discovery of the Ormaque deposit, followed just over a year later by the announcement of its inaugural Inferred Mineral Resource estimate.

The exploration discussed in this section was carried out by Integra and EGQ after the purchase of Integra. Exploration conducted on the site consists almost entirely of drilling programs discussed in Section 1. Geophysical mapping, resistivity / induced polarization surveying, surface sampling, and prospecting are discussed by zone in the following section.

Due to the limited bedrock exposure over most of the project area, exploration targeting relies heavily on geophysical surveying combined with analysis of historical mining and exploration data. Between February 18 and March 22, 2017, a high resolution AeroVision (UAV-MAG) survey was completed on the Lamaque Project by contractor Abitibi Geophysics, covering most of the claim blocks. Only the portion covered by the town was not surveyed. A total of 650 line-km was surveyed on 50 m spaced lines oriented north to south, with tie lines every 1,000 m and with a clearance height of roughly 50 m. The survey allowed identification of several magnetic anomalies of moderate to strong amplitudes. A series of nine exploration targets were recommended by the contractor based on the interpretation of the survey data.

In 2016, Integra contracted consultants SGS of Montreal and InnovExplo of Val-d'Or, Québec to conduct a property-scale targeting program. The targeting program used all the historical and recent exploration data on the property to generate a model for the property in order to help identify high-quality exploration targets. This compilation, along with the knowledge of the local geologists, identified and prioritized several additional targets, including the Sigma East Extension, the South-West target (located due south of the Lamaque West Plug), and the extension to the east of the Triangle deposit. Targeting studies since 2017 have built on this work through additional compilation and interpretation of historical and new exploration data, 3D modelling of the project area geology, integration of new geological data from development and production at the Triangle mine, and additional detailed geological mapping. A geomechanical modelling study completed in 2021, focusing on the Triangle deposit area, defined multiple new exploration targets proximal to the mine for future drill testing.

In December 2021, a HeliFalcon airborne gravity gradiometer survey was conducted by Xcalibur Multiphysics. The survey covered most of the Lamaque and Bourlamaque properties and was designed to help identify and mapped significant geological features and structures with the objective to refine the regional targeting efforts. The survey lines were oriented east-west and spaced at 100 m with a nominal terrain clearance of 35 m. Infill lines at 50 m were conducted over the Lamaque property for better resolution. Tie lines oriented north-south were surveyed at every 1,000 m through the survey. The survey totaled some 3,378.5 line-km. Results of the gradiometer survey are being used in a camp-wide re-interpretation of the geology and structural features that are responsible for concentrating orogenic gold deposits, similar to the Sigma, Lamaque and Triangle Deposits.

The following sections summarize the exploration work mainly focusing on the work completed during the most recent phase of exploration (2017 to present) on targets within the Lamaque Project area.

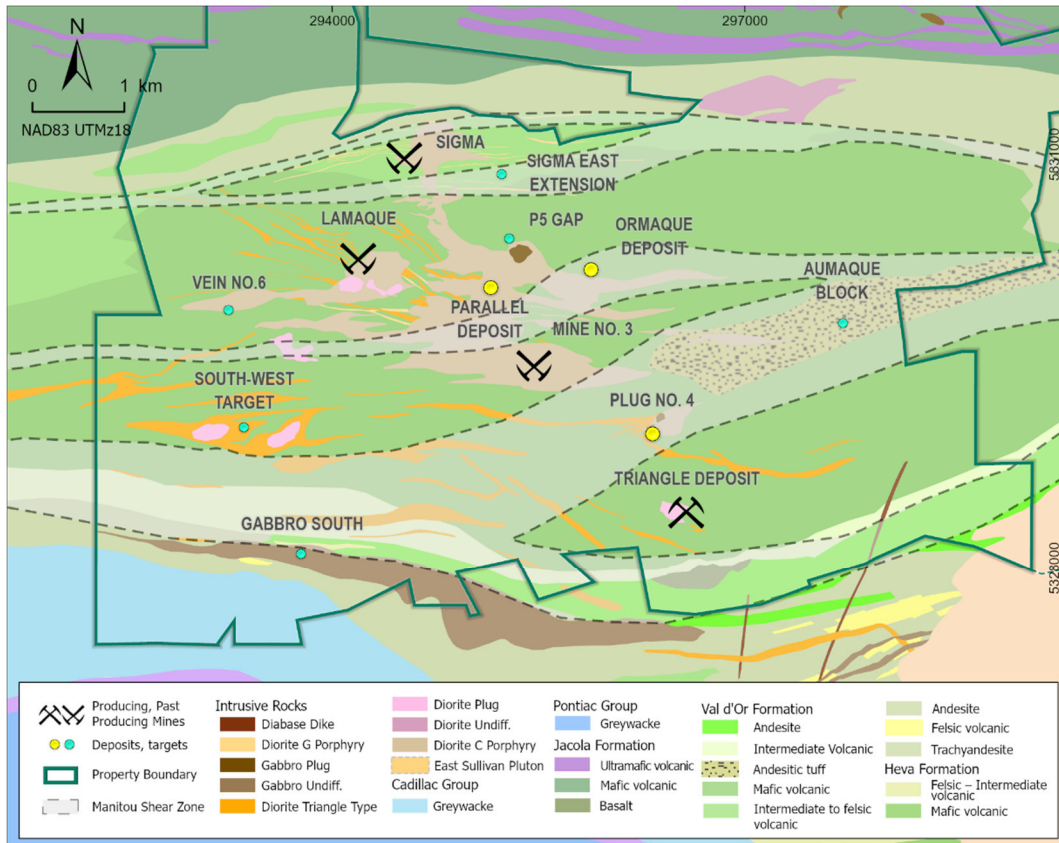

Figure 9-1: Geology of the Lamaque Project Area (Eldorado 2024)

## 9.2 South-West Target and Gabbro South

The South-West Target is located roughly 2 km south of the Lamaque Mine. It was identified mainly by the interpretation of a relatively small and isolated magnetic anomaly that shows similar characteristics to the Triangle deposit. An initial drill program was successful in intersecting mineralized shear zones hosting quartz-tourmaline veins, within an intrusion of similar composition as the Triangle Plug. Follow-up drilling conducted in the first part of 2019, intersected several mineralized structures/veins similar to the veins at Triangle, but failed to return economic gold results. No further work is planned at this stage on this target.

Located south of the South-West target, the Gabbro South target is interpreted as a large east-west trending gabbro sill, near the contact between the Val-d'Or Formation and the Cadillac Group. In May 2017, an Orevision time domain resistivity / induced polarization survey was conducted by contractor Abitibi Geophysics on the south-western area of the property. A total of 27.1 line-km were surveyed on 100 m spaced lines, and a total of 25 chargeable sources were identified. The anomalies are interpreted to be related to disseminated sulfide mineralization associated with potential east-west faults and shear zones.

### 9.3 Sigma East Extension

A small isolated magnetic anomaly was identified on the extension to the east of the Sigma Mine trend, roughly 1 km east of the open pit. Compilation of historical work showed that the limited drilling completed there had returned significant gold intercepts associated with quartz-tourmaline veins within large vertical shear zones.

In 2016, a small drill program consisting of six drill holes was completed to test this potential mineralization. The drilling intersected a series of sub-vertical shear zones striking east-west defining deformation corridors which are believed to be part of the northern Manitou Fault Zone. Additional drilling in 2018 failed to identify significant mineralization in the area, however recent interpretation is showing that several of the drill holes did not go deep enough to intersect the more favorable structure.

During the summer of 2022, a surface mapping program was conducted in the area east of the Sigma Mine. Outcrops were compiled from historical map and reference using Lidar data and used to plan traverses. The area hosts a series of outcrops that were stripped of their overburden in the mid-1990's by Placer Dome Inc. Geology and structural data from the mapped outcrops and stripped areas were validated in the context of the regional geology. All information were digitized into an ArcGIS Pro database. The data from the mapping program along with drill hole information was used to refine the geological map of the area and to update the 3D regional model. The program identified several potential targets based on this re-interpretation of the sector. Results were compiled into an internal report from Chris Siron dated June 17, 2022, and titled Structural Mapping and Target Generation, Sigma East.

### 9.4 Aumaque Block

During July to October 2015, prospecting and outcrop sampling were completed over the Aumaque Block. An outcrop stripping program revealed a sequence of blocky lapilli tuffs with trace to 1% pyrite-pyrrhotite and well-developed schistosity locally. Several quartz-calcite-chlorite and local tourmaline veins and veinlets with 1-5% pyrite, trace to 1% chalcopyrite and traces of pyrrhotite were identified.

A total of 285 channel samples of 1 m each were collected. Assay results vary from 0.005 to 51.1 g/t Au.

Late in 2015, a GPS-position Ground Magnetic Field survey was conducted over the area at a 50 m line spacing totaling 59 km. The survey was followed by an OreVision® survey on every other line (100 m line spacing). Both surveys were conducted by Abitibi Geophysics of Val-d'Or. The conductivity and chargeability results allowed mapping of several zones of potential mineralization along an east-west corridor and in part corresponding to zones that were discovered and developed underground but not mined by Aumaque Gold Mines in the 1940's.

Based on the results of these surveys and from the stripped outcrop sampling, a series of drill holes were planned and executed with the objective of identifying sulphide-rich zones with potential gold enrichment. A total of 11 drill holes totalling some 4,522 m were completed.

The Aumaque Block mainly consists of volcanoclastic units with lapilli and blocks of intermediate to felsic composition. These units often alternate with intermediate intrusive units varying from diorite, monzodiorite to gabbro-diorite. Usually, the units are chloritized with locally, in the most altered areas (subhorizontal and subvertical envelopes) of sericitization, silicification, ankeritization and albitization. The rock is fractured and at places schistose with highly sheared and deformed sections in the most strongly altered zones and forming subvertical corridors. Gold mineralization at Aumaque is highlighted by an abundance of semi-massive to massive sulphide (pyrite, chalcopyrite, and sphalerite) veinlets and veins with minor amounts of quartz-calcite veinlets and veins with trace to 2% pyrite. Best values vary from 0.5 g/t Au to 40.1 g/t Au over 1.0 m and 0.5 to 504 g/t Ag over 1.0 m with some anomalous values of Cu and Zn.

## 9.5 Secteur Nord

The Secteur Nord is defined as the area north of the Sigma mine. A large portion of the area is under the Sigma tailings pond. Historically the area has not been subjected to significant exploration efforts. Eldorado performed a short drill program in 2020 totaling 6 drillholes (3,280 m) testing an east-west striking deformation zone which is located underneath the Sigma tailings and had returned several high-grade gold results in historical drilling. The drilling intersected strongly foliated rocks consisting of an alternation of mafic and ultramafic volcanic rocks from the Jacola Formation. Quartz-tourmaline veins and veinlets were observed within or associated with the sheared sequence, but gold values were mostly low. In 2021, two additional drill holes were drilled to the north-east of the property, testing the area of the contact with the Bourlamaque Batholith.

The geology of the Secteur Nord consist mainly of the mafic and ultramafic rock sequences of the Jacola Formation. The only exposure of the Jacola is found on the eastern portion of the property and are present in five outcrops that were stripped of overburden in the mid-1990's by Placer Dome. In 2022, a compilation / interpretation of the area was completed along with a mapping program of the stripped outcrops by consultant Chris Siron, and results were discussed in an internal report by Chris R. Siron and Thomas Herbort dated December 01, 2022.

## 10 Drilling

The Lamaque Complex area has been drilled without interruption since 2009 using several drilling contractors. Surface drilling is completed by wireline method with NQ-size (47.6 mm core diameter) equipment using up to nine drill rigs. Underground drilling is completed using up to 13 rigs on BTW / BQTK (40.7 mm core diameter) caliber for infill campaigns and NQ caliber for delineation and exploration campaigns. Drillers place core into wooden core boxes with each box holding about 4.5 m of core. Core is processed by either Exploration or Mine Geology personnel for lithological and geotechnical logging, photography, and gold / geochemical sampling. Exploration and delineation core is split prior to sampling to keep records for future use or reference. Infill core is sampled whole and unsampled core is discarded. All data pertaining to drilling is captured using Geotic Log software and stored on a cloud-based SQL Server.

Drilling totals on the Triangle surface, Triangle underground, Plug No. 4, Parallel, and Ormaque deposits are shown in Table 10-1, Table 10-2, Table 10-3, and Table 10-4 respectively, and shown in Figure 10-1, Figure 10-2, Figure 10-3, Figure 10-4, and Figure 10-5. From July 2015 to the present, Integra / Eldorado was responsible for planning, core logging, interpretation and supervision, and data validation of the various diamond drill campaigns.

**Table 10-1: Summary of Triangle Deposit Drilling**

Period	No. Completed Holes	No. Surface Holes	No. Underground Holes	Meters
<2010	57	57		13,362
2011	9	9		3,149
2012	15	15		4,411
2013	28	28		13,757
2014	73	73		28,471
2015	101	101		66,549
2016	313	313		106,063
2017	425	234	191	81,714
2018	545	32	513	75,945
2019	825	28	797	119,701
2020	643	17	626	108,065
2021	627	11	616	117,679
2022	552	4	548	104,890
2023	565		565	115,751
2024	727		727	103,944
<b>TOTAL</b>	<b>5,505</b>	<b>922</b>	<b>4,583</b>	<b>1,063,451</b>

**Table 10-2: Summary of Plug No. 4 Deposit Drilling (Resource Eligible Holes Only)**

Period	No. Completed Holes	No. Surface Holes	No. Underground Holes	Meters
<2010	8	8		6,412
2012	15	15		15,806
2015	13	13		8,940

Period	No. Completed Holes	No. Surface Holes	No. Underground Holes	Meters
2016	4	4		3,117
2017	53	53		18,458
2019	1	1		830
2023	5		5	4,512
2024	13		13	4,128
<b>TOTAL</b>	<b>112</b>	<b>94</b>	<b>18</b>	<b>62,203</b>

Table 10-3: Summary of Parallel Deposit Drilling

Period	No. Completed Holes	No. Surface Holes	No. Underground Holes	Meters
<2010	135	119	16	33,028
2011	25	25		5,516
2012	5	5		1,208
2013	40	40		12,590
2014	6	6		1,020
2015	26	26		5,576
2018	6	6		2,311
2022	1	1		1,579
2023	9	9		7,084
<b>TOTAL</b>	<b>253</b>	<b>237</b>	<b>16</b>	<b>69,912</b>

Table 10-4: Summary of Ormaque Deposit Drilling

Period	No. Completed Holes	No. Surface Holes	No. Underground Holes	Meters
<2010	78	78		18,335
2011	6	6		1,234
2012	2	2		555
2014	25	25		6,029
2018	12	12		5,214
2019	22	22		10,990
2020	22	22		12,595
2021	52	52		27,632
2022	80	23	57	30,348
2023	165	17	148	52,015
2024	297	29	268	74,868
<b>TOTAL</b>	<b>761</b>	<b>288</b>	<b>473</b>	<b>239,815</b>

Since 2017, most of the drilling at the Triangle deposit has been from underground drill platforms. Most of the underground drill holes (1,984 drill holes totaling 223,701 m) were completed to define areas within the

various zones at an in-fill spacing of approximately 10 m by 10 m, ahead of development for planning purposes. There were 148 drill holes totaling 49,939 m that were completed to convert Inferred Mineral Resources to Measured and Indicated Mineral Resources and 123 drill holes totaling 23,520 m were completed to expand and test extensions of the mineralized zones.

The underground drilling programs were carried out by contractor Forage Orbit-Garant using hydraulic mobile drill rigs. The Triangle diamond-drill holes generally ranged in length from 200 m to 1,150 m, averaging 144 m. The longest hole drilled at Triangle totalled 2,198 m. Plug No. 4 drill holes ranged in length from 198 m to 1,275 m, averaging 761 m.

Surface drill holes were drilled at an inclination of between  $-50^{\circ}$  and  $-75^{\circ}$  and drilled mainly along  $350^{\circ}$  to  $10^{\circ}$  UTM N azimuths. Underground drill holes orientations vary depending on location of the drill platforms and have inclinations between  $-90^{\circ}$  and  $+45^{\circ}$ . During this period, the use of wedges and directional drilling became more important to help control deviations to intersect the targeted zones at Triangle and Plug No. 4. Down-hole surveys were taken every 3 m to 6 m intervals using a Reflex EZ-Trac multi-shot instrument. Drill collars from surface drill holes were surveyed by a local contractor Geoposition Arpenteurs Géomètres of Val-d'Or. Underground drill holes were surveyed by the mine survey team. Also, all underground diamond drill holes collars are obturated with 5 m cemented plugs in accordance with Québec mine safety regulations.

Eldorado reviewed the core logging procedures at site, and the drill core was found to be well handled and maintained. Core boxes were stored in metal racks in an organized "core farm" for easy access. Data collection was competently done. Core recovery in the mineralized units was excellent, averaging over 95%. Overall, the various drill programs at Triangle, Parallel, Plug No. 4 and Ormaque, and relevant data capture, were performed in a competent manner.

No drilling, sampling, or recovery factors could materially impact on the accuracy or reliability of the results.

In the opinion of the QP, diamond drilling for core is the most appropriate method for the Lamaque Project due to the depth and rock competency and has been employed on site for decades. The methodology and procedures followed by EGQ meet or exceed standards within the gold mining industry. The historical operators generally operated within standards known and expected at the time. The geological database is reliable based on the extensive drilling programs, with over 800,000 m of drilling conducted at the Lamaque Project. Drilling data is considered representative of the deposits and sufficient to support Mineral Resource and Mineral Reserve estimation in this Technical Report.

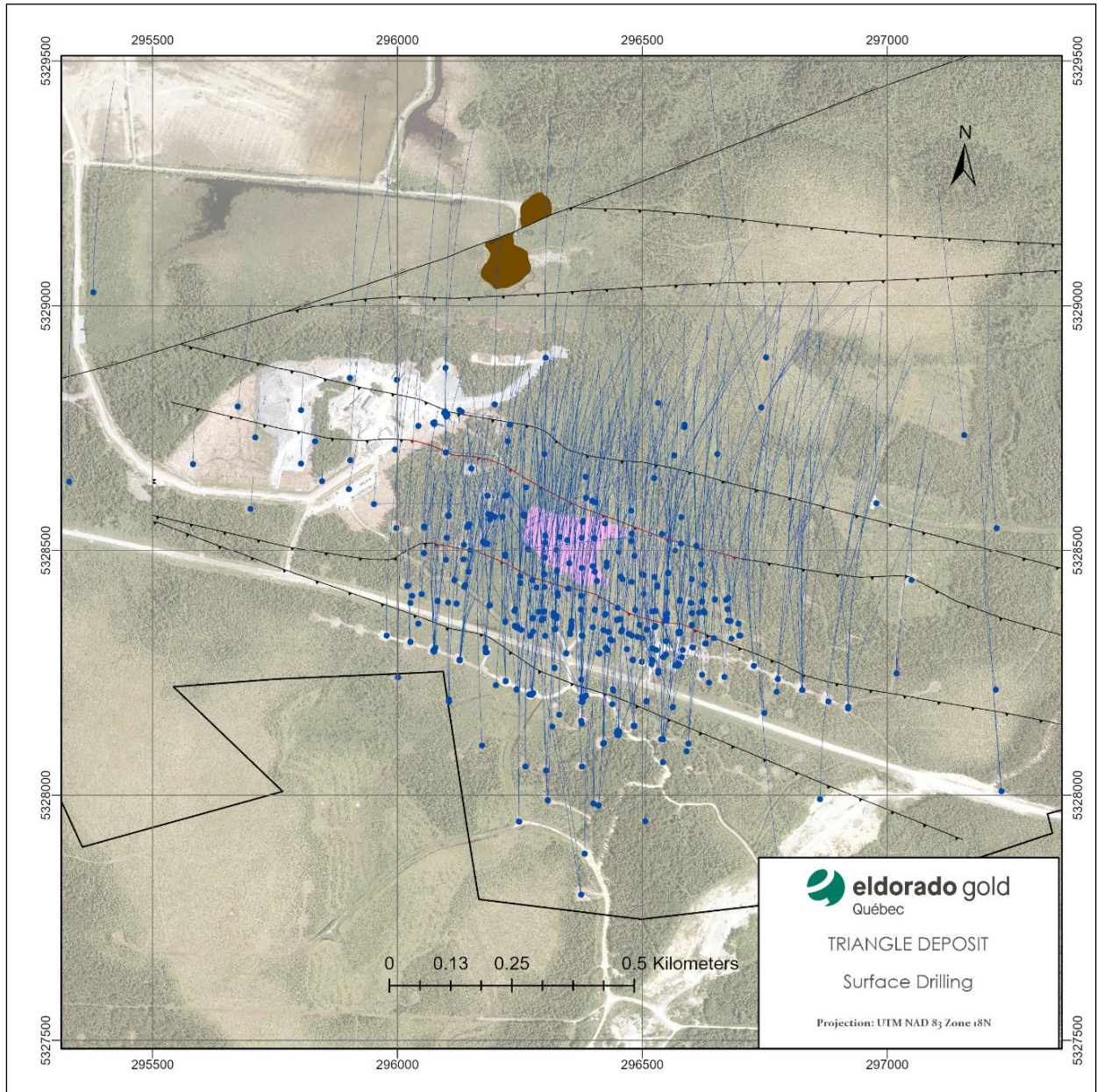

Figure 10-1: Triangle Deposit Drillhole Location Map (Eldorado 2024)

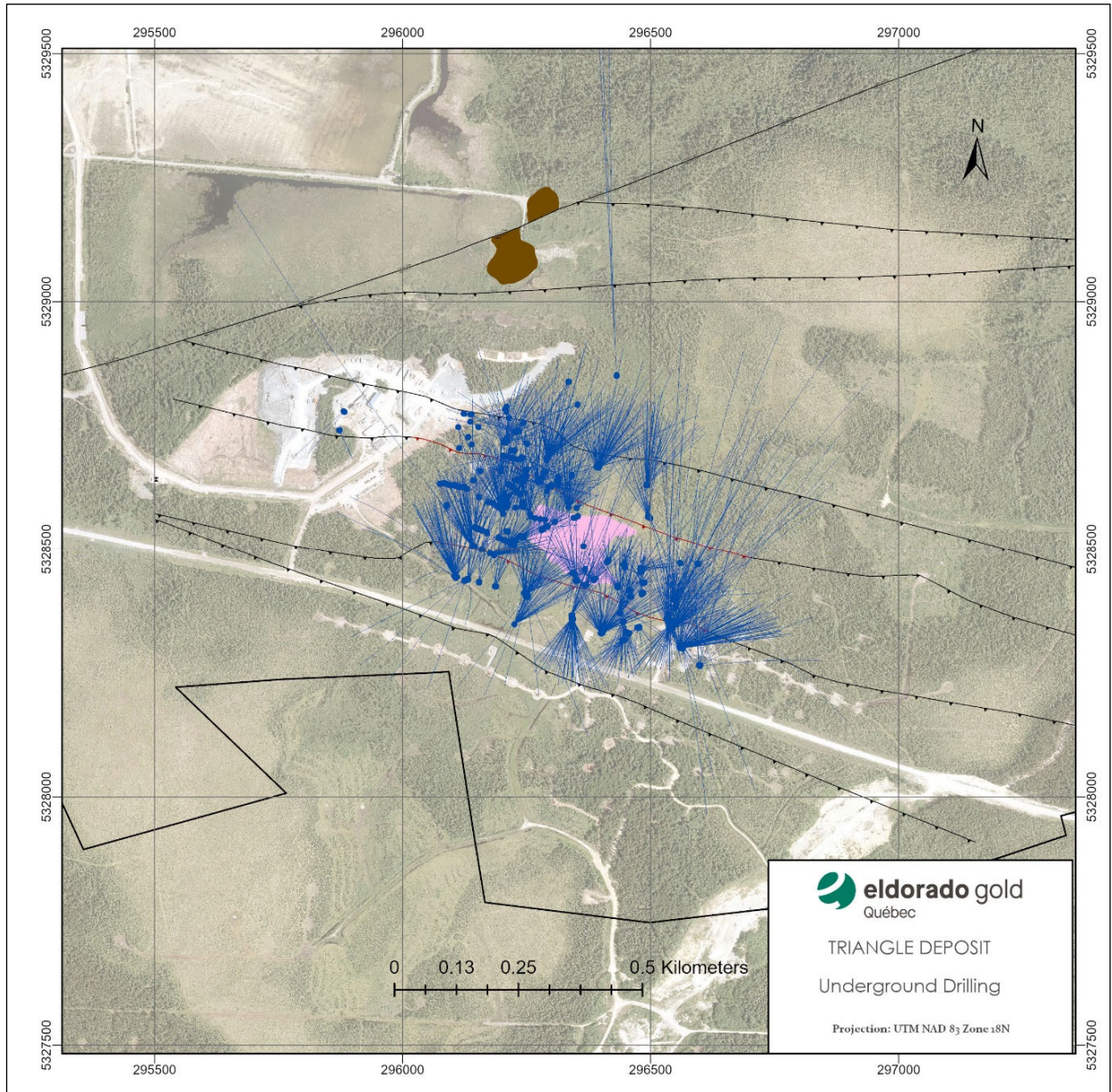

Figure 10-2: Triangle Deposit Underground Drillhole Location Map (Eldorado 2024)

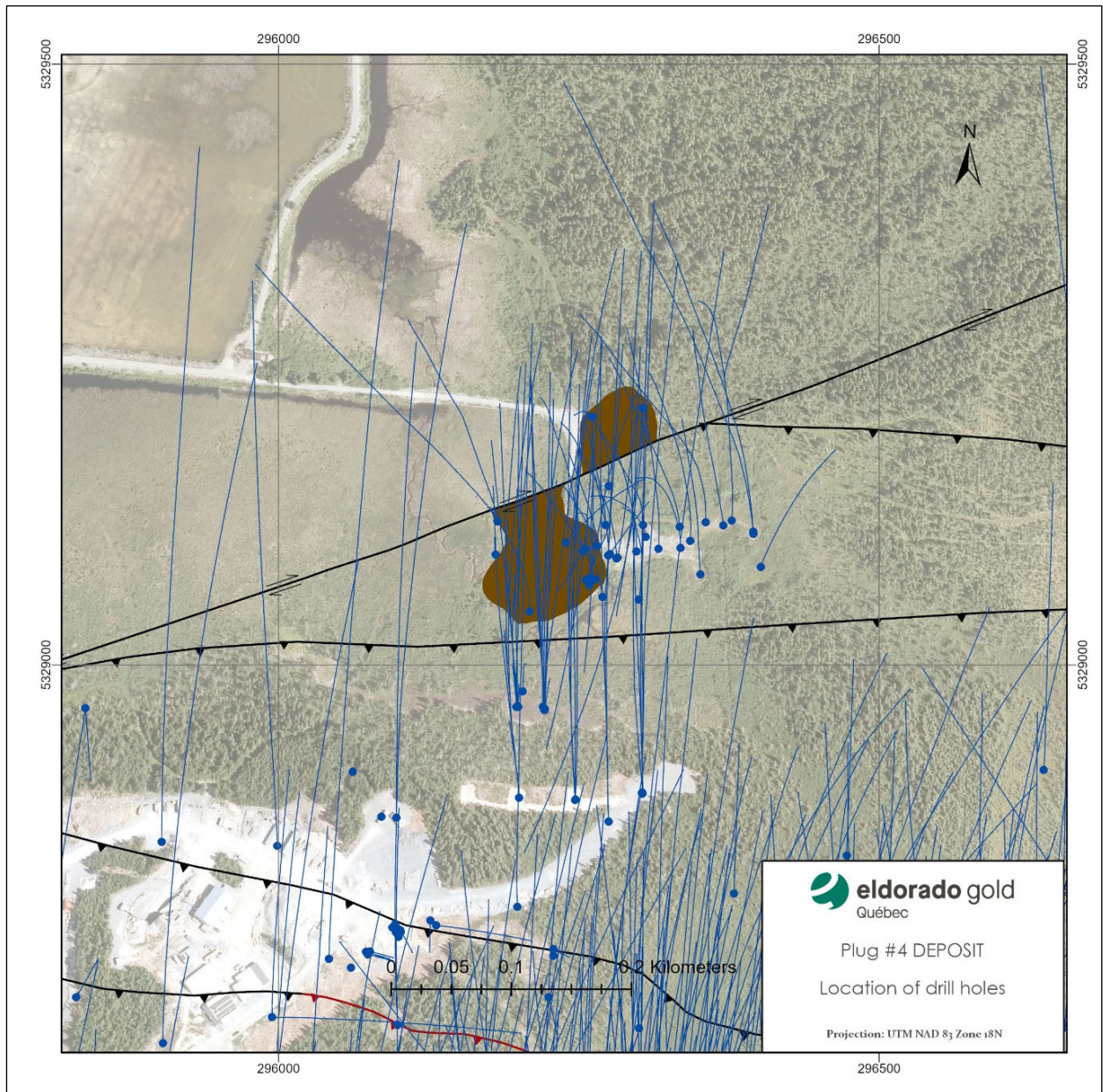
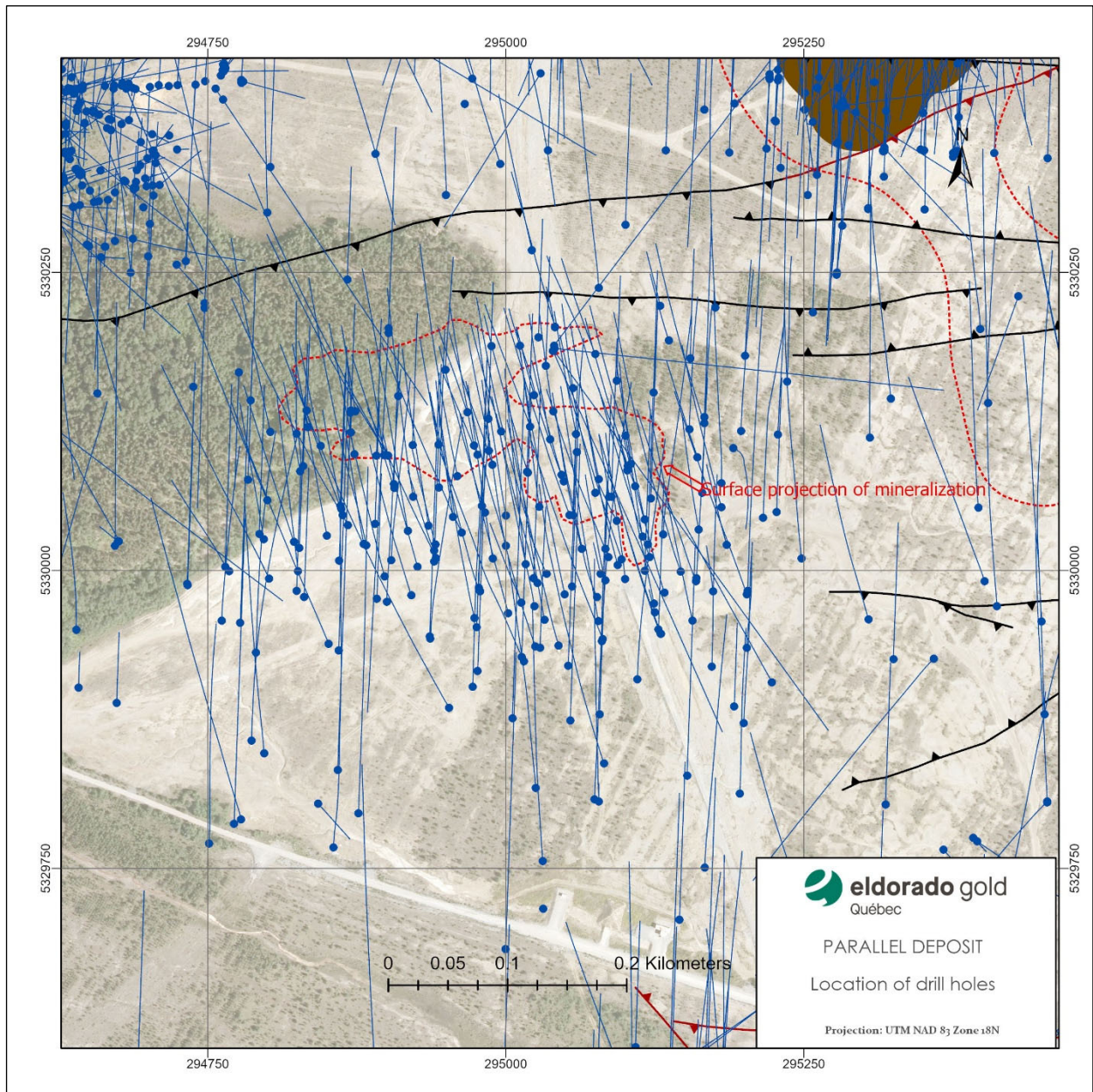

Figure 10-3: Plug No. 4 Deposit Drillhole Location Map (Eldorado 2024)



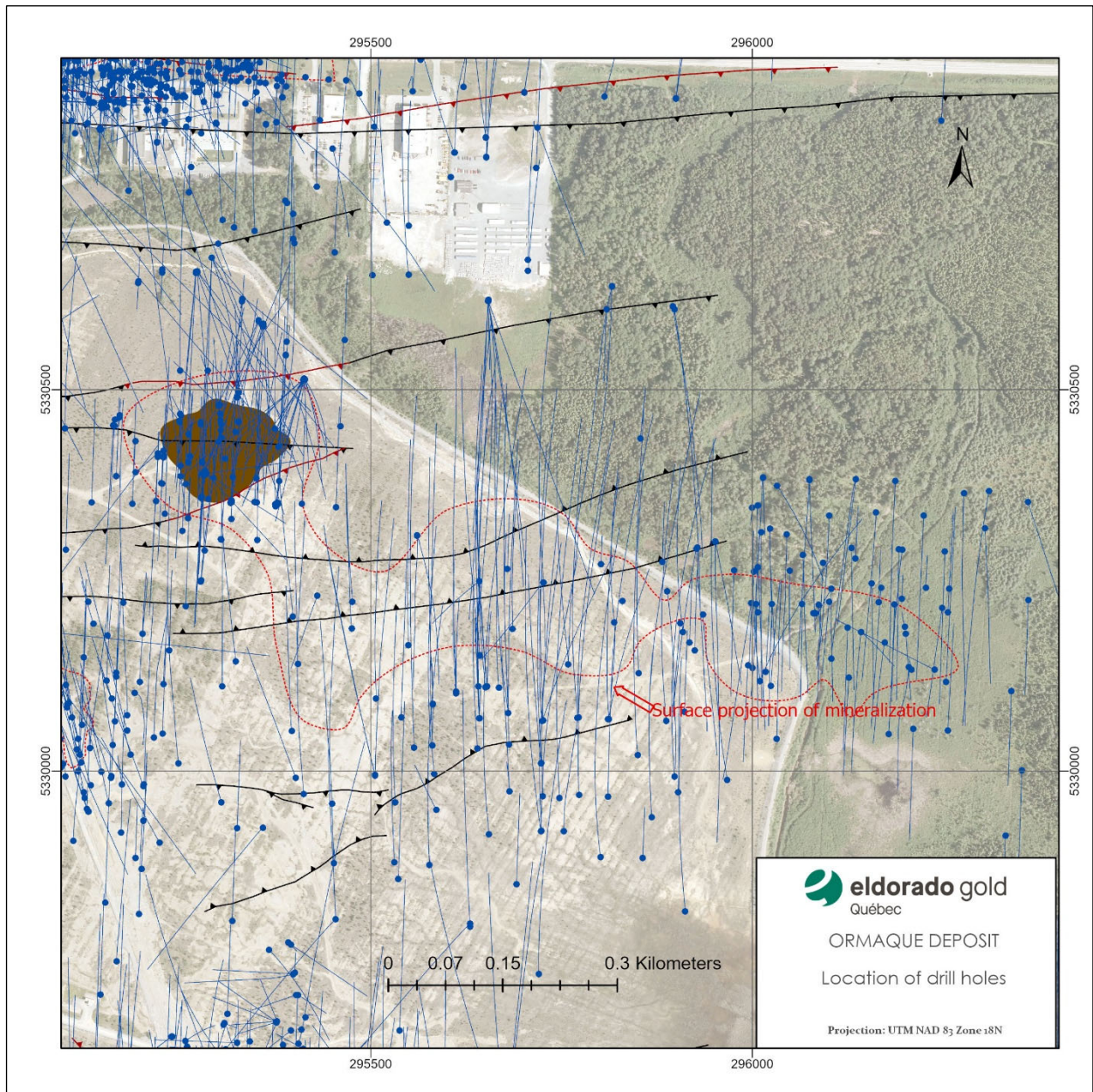

Figure 10-5: Ormaque Deposit Drillhole Location Map (Eldorado 2024)

## 11 Sample Preparation, Analyses, and Security

The sample preparation and quality assurance and control (QA/QC) protocols initially established in 2009 were followed for all subsequent drilling programs at Lamaque. As discussed in Section 1, this section will focus on the sampling and analyses, and QA/QC results from samples derived from drill campaigns.

Sample intervals are marked up on the drill core by the logging geologist. All vein and shear zone occurrences are sampled with additional “bracket sampling” into un-mineralized host rock on both sides of the veins or shear zones. Typically, about 40% of a hole is sampled. The core is cut at the Company’s core shack facilities in Val-d’Or, Québec. For security and quality control, diamond drill core samples are catalogued on sample shipment memos. Standards, duplicates, and blanks are inserted into the sample stream by Eldorado staff. Shipments of samples are made daily to the laboratory in large sample bags that are sealed. Upon delivery to the laboratory, the shipment memo is signed by the receiving personnel of the lab. Information is entered into the database to keep track of all shipments and samples.

The core samples are sent for preparation and analyses to Bourlamaque Assay Laboratories Ltd in Val-d’Or as the primary laboratory for surface drilling and at times a secondary laboratory, ALS Global laboratory in Val-d’Or, was used. Underground drilling core samples are sent to ALS Global laboratory in Val-d’Or. Both laboratories are commercial laboratories and are independent from Eldorado. ALS Global laboratory is accredited ISO 17025.

The remaining core is stored at the Company’s core handling and storage facilities in Val-d’Or, Québec. All drill core since the 2006 campaigns are stored in metal racks which permits easy access for any additional work. Some of the drill core from programs before 2006 are available, but most have been destroyed by previous owners.

### 11.1 Sample Preparation, Analyses

Sample preparation procedures for routine fire assaying start with crushing the entire sample to 10 mesh. A 250 g subsample is split by a riffle unit and pulverized to 85% minus 200 mesh. This subsample is sent for assay where a 30 g subsample is taken and fire-assayed with an AA spectrometry finish. During exploration phases, any values greater than 5 g/t Au are re-assayed with a gravimetric finish. For infill and conversion drilling, the threshold for gravimetric finish is increased to 10 g/t Au.

The sample batches contain QA/QC samples comprising SRMs, duplicates, and blanks. These are inserted at a general rate of 1 in 20, 1 in 50, and 1 in 20, respectively. The SRMs are purchased from commercial facilities specializing in their manufacture (Rock Labs and OREAS SRMs purchased from Analytical Solution Ltd.). All material used for blank samples consists of locally sourced barren limestone. Laboratories also inserted their own quality control samples.

### 11.2 Quality Assurance and Quality Control

The QA/QC procedures assured that the assay results from a sample batch meet certain rules in order to be considered “passed” and allowed to be included into the database. The pass-fail criteria are as follows.

- Automatic batch failure if a standard result is greater than the round-robin limit of three standard deviations.
- Automatic batch failure if the field blank result is over 0.02 g/t Au.

If the batch fails, it is re-assayed until it passes.

### 11.2.1 Blank Sample Performance

The field blank sample is taken from a gold-barren sample of crushed white marble and inserted at every 20<sup>th</sup> sample. The quality control protocol stipulates that if any result returns a value above 20 ppb Au, the batch of samples containing the blank should be re-assayed. Exception is given to results returned from unmineralized intervals. Assay performance of field blanks from surface is shown on Figure 11-1.

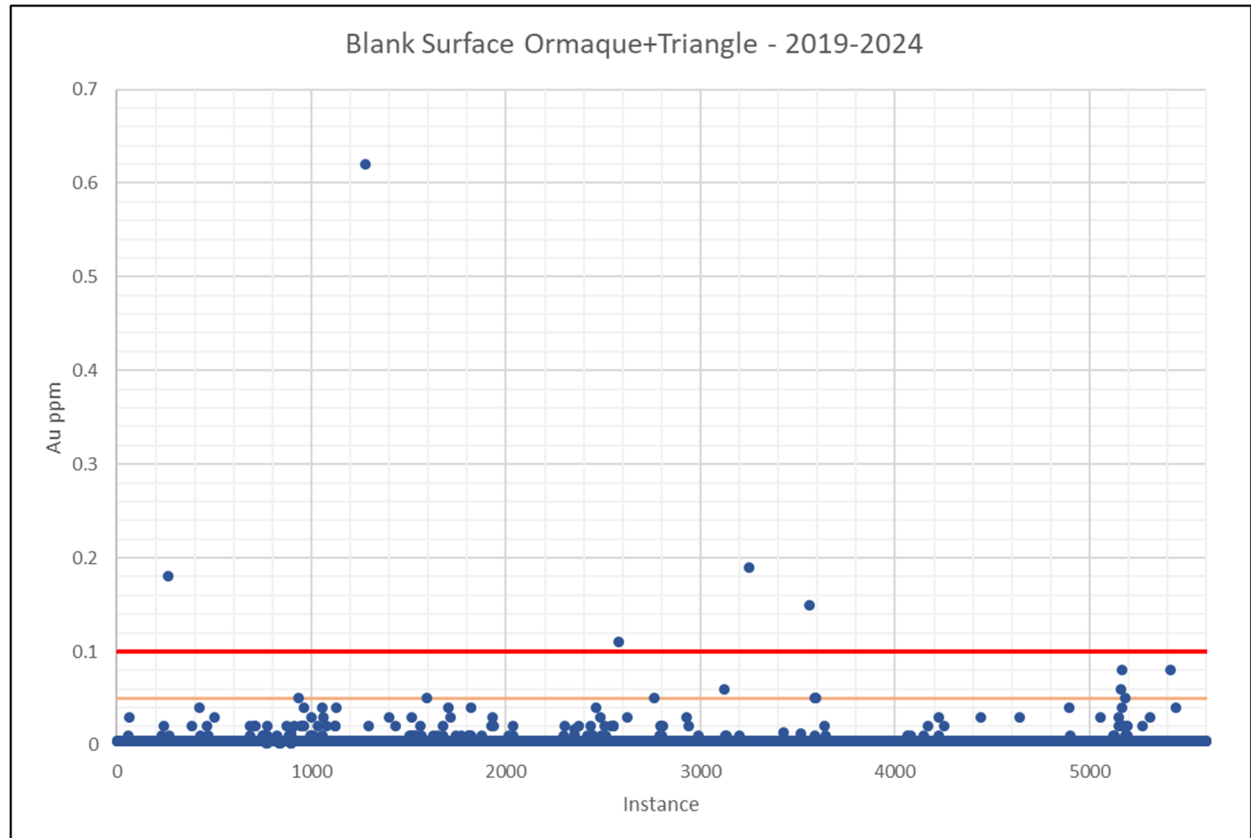

Figure 11-1: Lamaque Blank Data – 2019 to 2024 (Eldorado)

### 11.2.2 Standard Reference Material Performance

Eldorado strictly monitors the performance of the SRM samples as the assay results arrive on site. Assaying during 2015 through to the 2024 drill campaigns used 31 different SRMs that covered a grade range from 0.34 g/t Au to 18.17 g/t Au (Table 11-1). These were inserted into the sample stream at every 20<sup>th</sup> sample. Charts of the individual SRMs are shown on Figure 11-2 and Figure 11-3. At the data cut-off date, all samples had passed acceptance criteria. Some failures represent SRMs that upon investigation were found to have been inserted amongst unmineralized samples. These were ignored and not used in any trend analysis of that SRM sample.

**Table 11-1: Standard Reference Material Samples Used at Lamaque Project, 2015 to 2024**

Name	Source	CODE	Element	Au g/t	Standard	Period Used	
				Mean	Deviation	From	To
SN74	Rocklab	STD12	Au g/t	8.981	0.222	Mar-14	Sep-15
SL77	Rocklab	STD13	Au g/t	5.181	0.156	Feb-14	May-15
SE68	Rocklab	STD15	Au g/t	0.599	0.013	Mar-14	Mar-16
SK78	Rocklab	STD16	Au g/t	4.134	0.138	Apr-14	Apr-16
SF67	Rocklab	STD17	Au g/t	0.835	0.021	Jul-14	Aug-15
SJ80	Rocklab	STD18	Au g/t	2.656	0.057	Aug-14	Feb-16
SN75	Rocklab	STD19	Au g/t	8.671	0.199	Feb-15	Apr-16
SL76	Rocklab	STD20	Au g/t	5.960	0.192	Jan-15	May-16
SF85	Rocklab	STD21	Au g/t	0.848	0.018	Oct-15	Apr-16
SP73	Rocklab	STD22	Au g/t	18.170	0.420	Oct-15	Apr-16
OREAS 200	Oreas	STD23	Au g/t	0.340	0.012	Apr-16	Jan-23
OREAS 205	Oreas	STD24	Au g/t	1.244	0.053	Apr-16	Dec-16
OREAS 214	Oreas	STD29	Au g/t	3.030	0.082	Jan-19	Oct-22
OREAS 215	Oreas	STD25	Au g/t	3.540	0.097	Apr-16	Dec-22
OREAS 216	Oreas	STD26	Au g/t	6.660	0.155	Apr-16	Feb-23
OREAS 216b	Oreas	STD34	Au g/t	6.66	0.158	Dec-20	present
OREAS 209	Oreas	STD27	Au g/t	1.580	0.044	Feb-17	Nov-22
OREAS 217	Oreas	STD28	Au g/t	0.338	0.010	Oct-17	Aug-22
OREAS 221	Oreas	STD31	Au g/t	1.062	0.036	Sep-19	Jan-23
OREAS 229b	Oreas	STD30	Au g/t	11.95	0.288	Jan-19	present
OREAS 230	Oreas	STD37	Au g/t	0.337	0.013	Jul-21	present
OREAS 231	Oreas	STD43	Au g/t	0.542	0.015	Feb-23	present
OREAS 233	Oreas	STD38	Au g/t	1.05	0.029	Dec-21	present
OREAS 238	Oreas	STD32	Au g/t	3.03	0.08	Oct-19	Dec-23
OREAS 238b	Oreas	STD42	Au g/t	3.08	0.085	Feb-23	present
OREAS 239	Oreas	STD35	Au g/t	3.55	0.086	Mar-21	Apr-24
OREAS 239b	Oreas	STD44	Au g/t	3.61	0.11	Mar-24	present
OREAS 241	Oreas	STD39	Au g/t	6.91	0.309	Jul-22	present
OREAS 258	Oreas	STD36	Au g/t	11.15	0.259	Jun-21	present
OREAS 277	Oreas	STD40	Au g/t	3.39	0.12	Sep-21	present
OREAS 611	Oreas	STD33	Au g/t	15.7	0.601	Mar-20	present

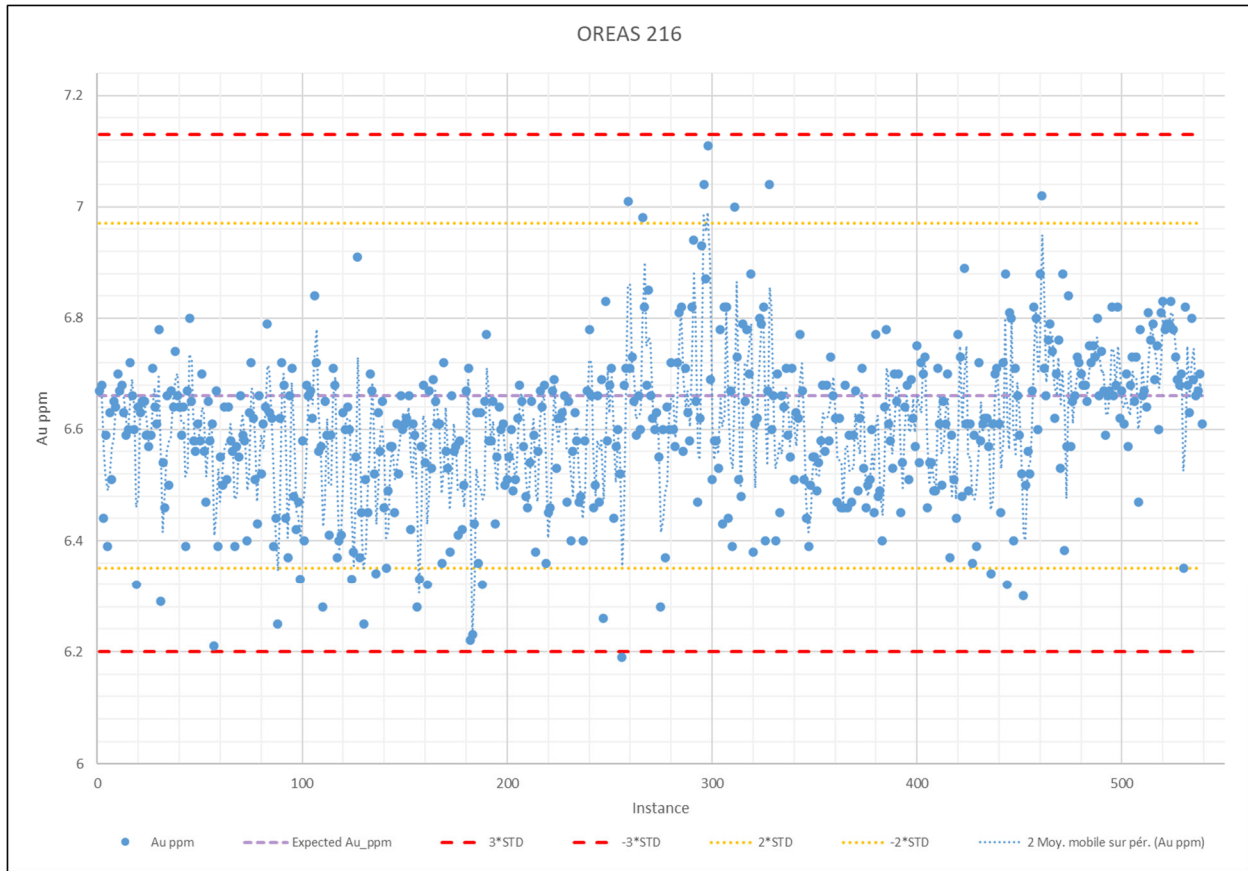
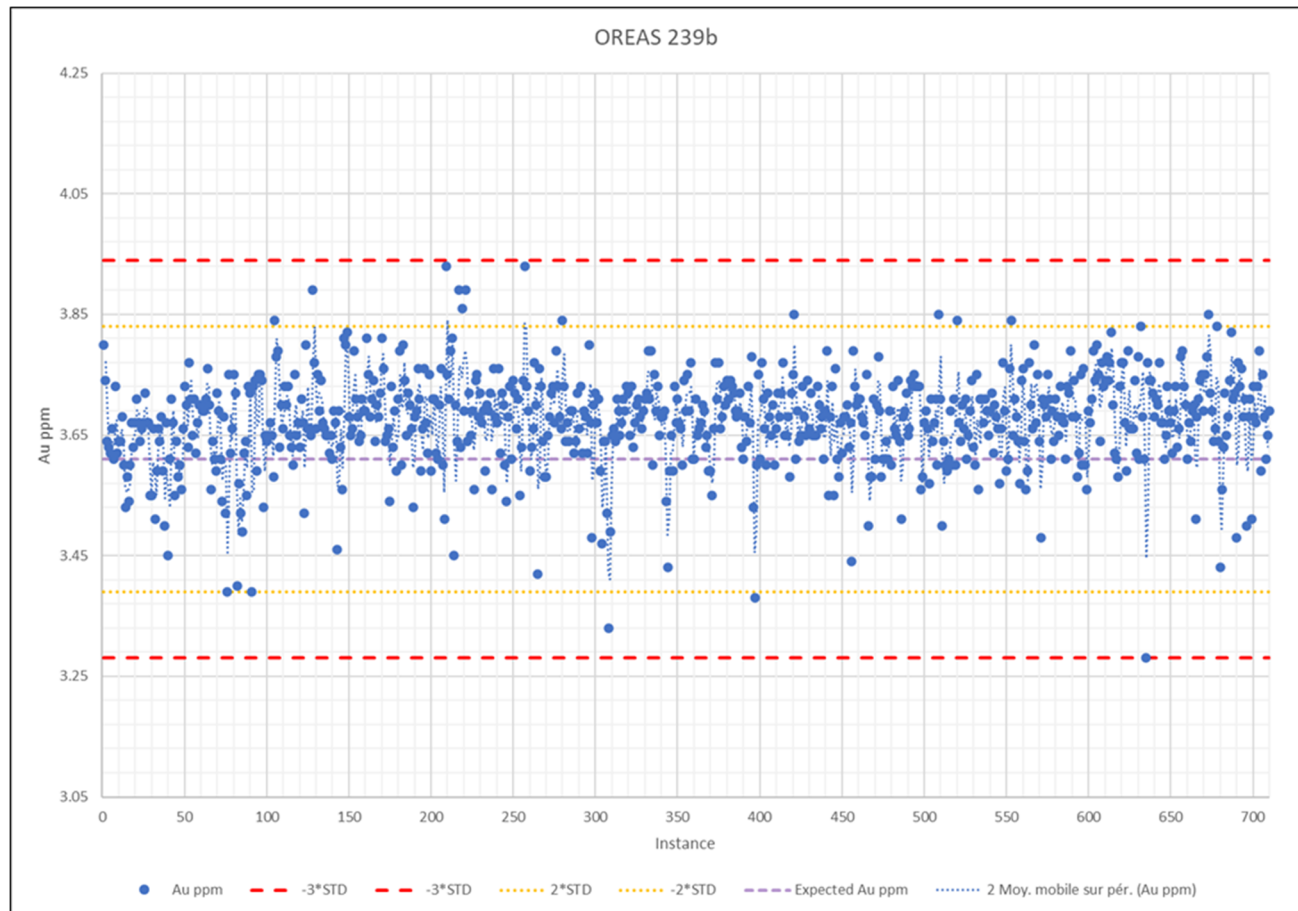

Figure 11-2: SRM Chart for Standard 26 (Oreas 216), 2017 to 2023 (Eldorado)



**Figure 11-3: SRM Chart for Standard 44 (Oreas 239b), 2023 to 2024 (Eldorado)**

### 11.2.3 Duplicate Performance

Eldorado implemented a program which monitored data from regularly submitted coarse reject duplicates. The duplicate is prepared by taking half of the crushed material derived from the original sample. These were inserted at every 50<sup>th</sup> sample. Additionally, every mineralized interval also contained at least one duplicate sample. The duplicate data are shown in a relative difference chart on Figure 11-4. In general, a maximum difference of 20% is recommended for the coarse reject duplicates. However, in gold mineralized systems that typically display effects due to extreme grades combined with the propensity for readily liberated gold during comminution (i.e., sample preparation), a higher scatter of between 30% to 40% may occur. This is what is observed at the Lamaque Project.

To confirm that the extreme grades and liberation issues associated with the gold mineralization at the Lamaque Project are random, effects due to potential bias were investigated in a recent re-submittal of duplicate samples for assay. The results are displayed on a Quantile – Quantile (Q-Q) plot in Figure 11-5. If the distribution lies on or oscillates tightly about the 1:1 line, then the sample population is unbiased. This is the pattern observed.

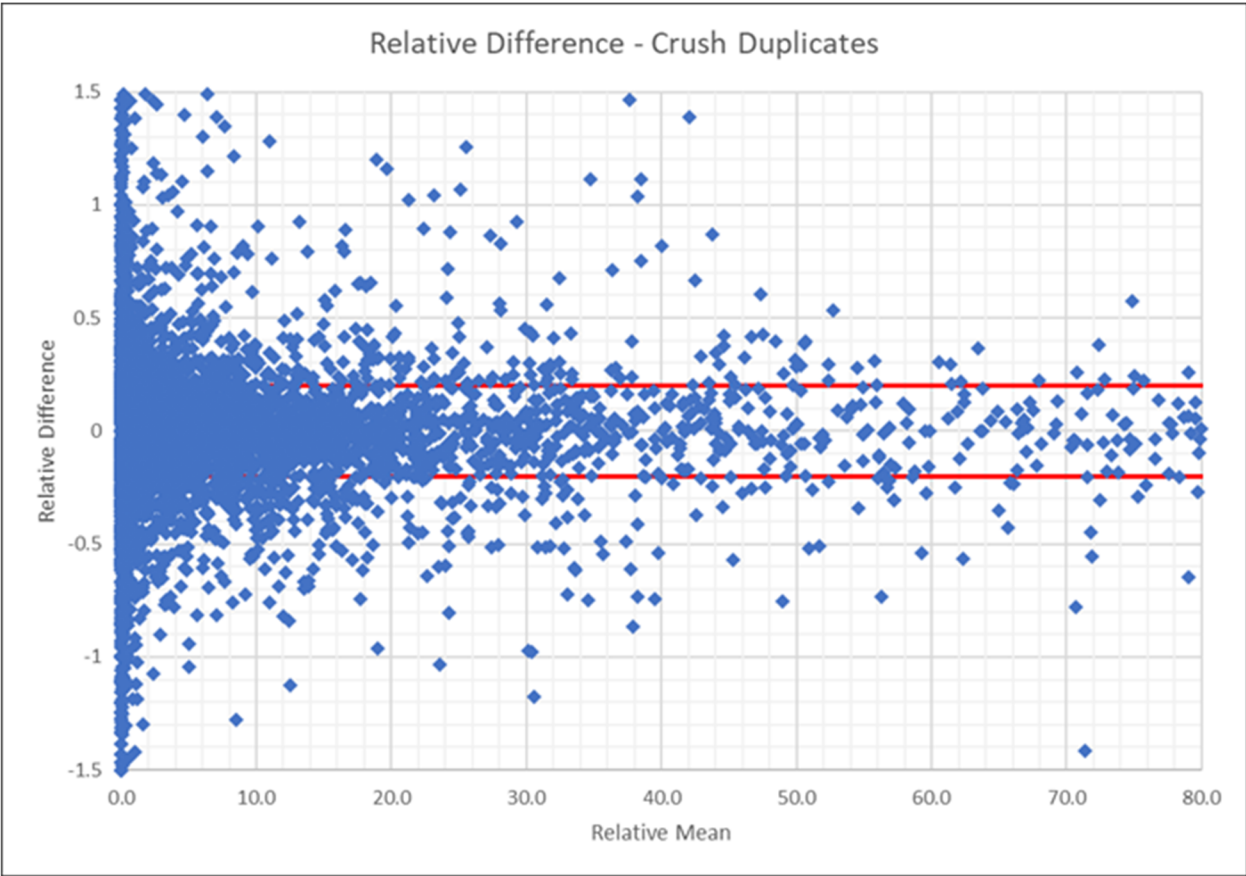

Figure 11-4: Relative Difference Plot of Gold Duplicate Data, 2017 to 2024 (Eldorado)

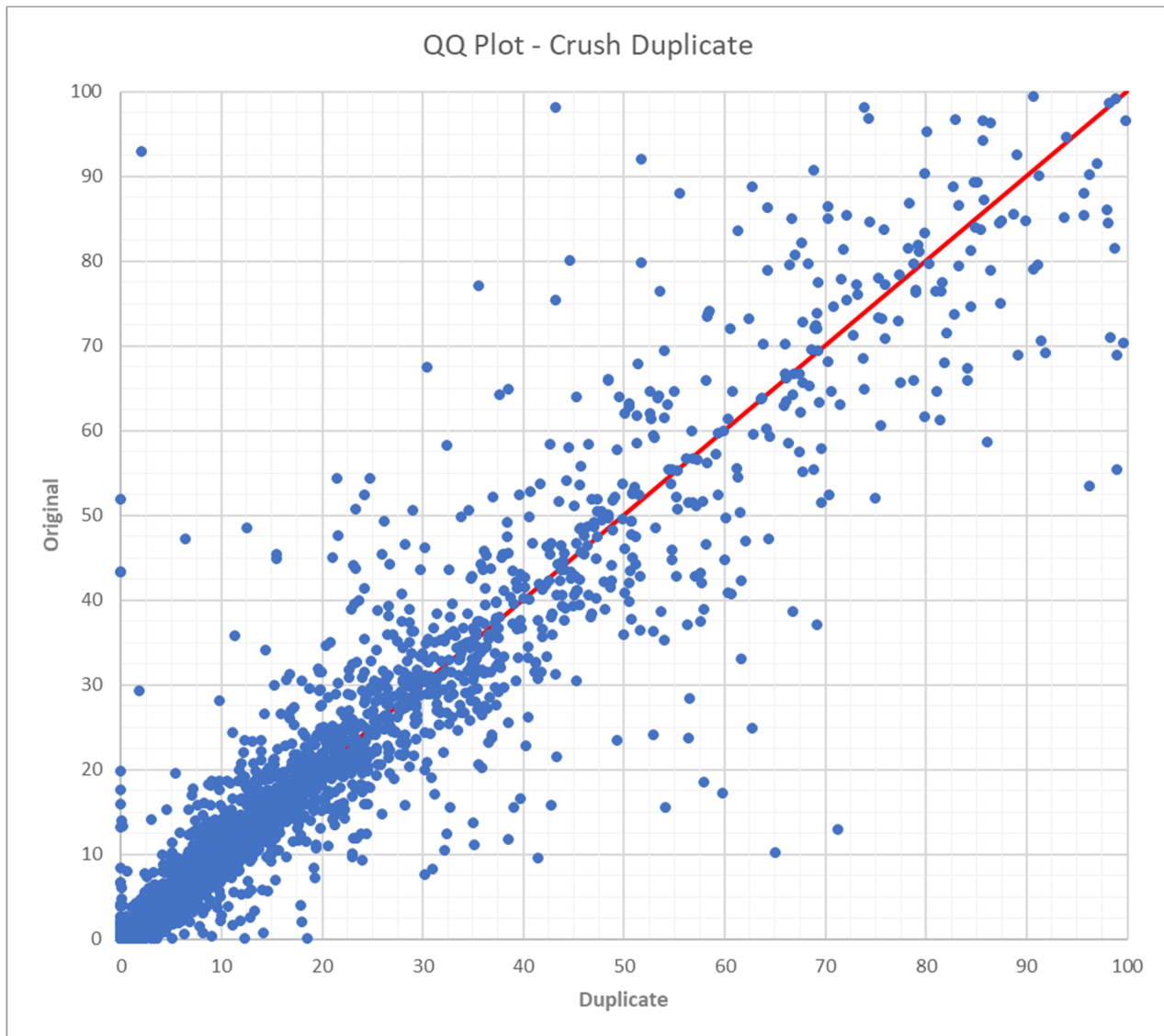

Figure 11-5: Q-Q Plot for Gold Duplicate Data, 2017 to 2024 (Eldorado)

### 11.3 Concluding Statement

In the QP's opinion, the QA/QC results demonstrate that the Lamaque Complex's sample preparation, analytical procedures, and database for assays obtained from 2017 to 2024 is sufficiently accurate and precise for Mineral Resource estimation.

The QP is not aware of any sampling or assaying factors that may materially impact the Mineral Resource estimate discussed in Section 1.

There are currently no recommendations to improve data collection and processing.

## 12 Data Verification

### 12.1 Drill Data Handling and Security

Daily routine checks are conducted by EGQ geologists and technicians. From collar positioning to borehole deviation, each entry has its sets of verification such as visual verification to comparison with planned specifications to ensure an error-free database. Once all items had been deemed error-free, the borehole is tagged as “final” and may be used for resource estimation. Each point of validation is dated and recorded in the database.

Random checks are conducted punctually to verify any discrepancies between original data such as lab certificates and downhole deviation surveys and the database entry.

#### 12.1.1 Core Logging Data

Core logging data is captured directly into digital interface and stored in a SQL database using the GeoticLog software. Built-in checks within the database system contribute to data integrity by:

- Requiring geologists to choose geological codes from pick lists;
- Preventing overlapping intervals and intervals that extend beyond borehole actual depth;
- Maximizing data import such as hole deviation, geochemical analysis and gold assays.

#### 12.1.2 Analytical Data

All assays are imported into the geological database using GeoticLog importation interface. All assays certificates are provided to EGQ under the form of a .csv file using a predetermined templates. Limited personnel are assigned to assays importation. The resource geologist has the final responsibility to validate that analytical data are compliant with QA/QC program.

### 12.2 Data Verification by Qualified Persons

#### 12.2.1 David Sutherland, P.Eng

Mr. David Sutherland, an employee based at Eldorado’s Vancouver Corporate Office, holds the role of Senior Manager, Projects and Technical Studies. With visits to the site since 2020, including his latest visit on May 28 to 30, 2024, Mr. Sutherland reviewed the historic operations data, internal, and third-party designs, current capital and operating budgets, and ongoing construction costs. Review meetings were conducted with the Lamaque team and third-party consultants involved in the support studies based on these verifications, it is the opinion of the QP that the cost models are sufficient to support the Technical Report at a prefeasibility level and support the continued operation of the Lamaque Project.

#### 12.2.2 Jacques Simoneau, P.Geo.

Mr. Jacques Simoneau, an employee based at EGQ’s Lamaque Complex, holds the role of Director of Exploration, Eastern Canada, overseeing the exploration programmes at the Lamaque Project. Mr. Simoneau has validated the integrity of the drilling database. Points of validation include, and are not limited to, the absence of discrepancy between the assay table and the original laboratory certificates, and absence of error in diamond drill hole collar locations and hole deviation surveys. He also ensured the validity of the geological information as described by the geologists. It is in the opinion of the QP that drilling information used for the geological modelling and resources estimation produced by EGQ is consistent with the industry best practices and is sufficiently accurate to support the Mineral Resources disclosed in this report.

### **12.2.3 Peter Lind, Eng., P.Eng.**

Mr. Peter Lind, an employee based at Eldorado's Vancouver Corporate Office, holds the role of Vice President, Technical Services. With frequent visits to the site since 2021, including his latest visit September 16, 2024, Mr. Lind reviewed testwork programs and results including assay data from metallurgical head samples and testwork products. Additionally, he reviewed processing costs and sustaining capital costs to support the calculation of cut-off values. Based on these verifications, it is the opinion of the QP that the metallurgical testwork supports the continuing processing of future ores through the Lamaque Complex Sigma process plant.

### **12.2.4 Jessy Thelland, P.Geo.**

Mr. Jessy Thelland, an employee based at EGQ's Lamaque Complex, holds the role of Director of Technical Services, overseeing the activities for both the Geology and the Engineering departments. Mr. Thelland has validated the integrity of the geological database. Points of validation include, and are not limited to, the absence of discrepancy between the assay table and the original laboratory certificates, and absence of error in diamond drill hole collar location and hole deviation surveys. He also ensured that geological modelling and the subsequent block modeling supporting the resource estimates respected internal protocols and were supported by adequate scientific basis. It is in the opinion of the QP that the resources shape and grade interpolation produced by EGQ is consistent with the industry best practices and is sufficiently accurate to support the Mineral Resources disclosed in this report.

Mr. Thelland also led the team in charge of the mine planning and mine support, rock mechanic, and ventilation pertaining to the Lamaque Complex. Mr. Thelland ensured that all key assumption included in the mine design and scheduling such as operating costs, mining performance, constraints linked to rock mechanics, and ventilation were appropriate. It is in the opinion of the QP that the underlying modifying factor are sufficiently accurate to support the Mineral Reserves disclosed in this report.

### **12.2.5 Philippe Groleau, P.Eng, MBA**

Mr. Philippe Groleau, an employee based at EGQ's Lamaque Complex, holds the role of Senior Strategic Planner, acting as project manager for different activities at the Lamaque Complex including Ormaque technical studies and the on-going bulk sample campaign. He led the mining engineering project team that designed the mine and ensured that the Ormaque production plan and assumptions are accurate and realistic, based on the geotechnical data gathered. He also validated the ventilation network, mining method, equipment fleet, and production schedule, as well as the other aspects contributing to the mining cost and performance. It is in the opinion of the QP that the data is sufficient and accurate at a prefeasibility level to support the Mineral Reserve disclosed in this Technical Report.

### **12.2.6 Mehdi Bouanani, P.Eng**

Mr. Mehdi Bouanani, an employee based at EGQ's Lamaque Complex, holds the role of Senior Director, Projects and Construction. Mr. Bouanani reviewed the capital budgets, surface installations, tailing management, and ongoing construction costs. Based on these verifications, it is the opinion of the QP that the cost models are sufficient to support the Technical Report at a prefeasibility level and support the continued operation of the Lamaque Project.

### **12.2.7 Vu Tran, ing.**

Mr. Vu Tran, an employee based at EGQ's Lamaque Complex, holds the role of Senior Geotechnical Engineer, Projects and Construction. Mr. Tran reviewed the studies, monitored ongoing construction, and site

investigations regarding the design and operation of the tailings and water management activities. Based on these verifications, it is the opinion of the QP that the tailings and water management approach are sufficient to support the Technical Report at a prefeasibility level and support the continued operation of the Lamaque Project.

## 13 Mineral Processing and Metallurgical Testing

Ore from upper Triangle is being processed at the Sigma mill and has been subjected to extensive metallurgical test work and is backed by six years of operational data. Test work started during Integra Gold's early drilling programs and continues through today. The current programs assess new target areas as well as continuous optimization of the current mineral processing operation.

Initial testwork programs centred primarily on zones C1 through C5 of the Triangle deposit and aligns with the production zones mined over the last six years. These zones are representative of the majority of the Mineral Reserves at Triangle. The following test work programs were carried out at third party laboratories between 2012 and 2018:

- ALS Metallurgy (Kamloops, BC), 2012 – 2014
- SGS Minerals Services (Lakefield, ON), 2016
- Bureau Veritas Commodities Canada (Richmond, BC), 2017 through 2018

Details of these programs were previously reported in the 2018 Prefeasibility Study and are only presented in summary form here.

Testwork has been carried out by Bureau Veritas to assess the metallurgical characteristics of samples from deeper zones in Triangle and from the Ormaque deposit (Chen, S., Shi, A., Metallurgical and Tailing Testing on Triangle Met Samples C5 to C7 – Lamaque Gold Project, Quebec, December 21, 2020) and (Chen, S., Shi, A, Metallurgical Testing on Samples from Deep Triangle Zones and Ormaque deposit Located in Quebec, Canada, September 20, 2021). Preliminary results from testwork carried out on additional samples from the Ormaque deposit are also included.

### 13.1 Initial Testwork on Plug 4, Triangle, Parallel, and Fortune Composites

In 2012 through 2014, ALS Metallurgy Kamloops carried out three testwork programs on ore samples from the Lamaque Project. Testing was carried out on composites that were produced from different proportions of ore from the Plug No. 4, Triangle deposits (Cluster 1) and the Parallel deposit and Fortune zone (Cluster 2), subdivided into three grade ranges.

The composite samples were homogenized and rotary split into 2 kg charges and a Master Composite was also prepared.

#### 13.1.1 Comminution Testwork

A Bond ball mill work index (BWI) test, with a closing screen size of 106  $\mu\text{m}$ , was conducted on the Master Composite, the Cluster 1 Composite, and the Cluster 2 Composite. The BWI ranged from 13.8 kWh/t to 14.9 kWh/t. This is considered average in terms of hardness.

#### 13.1.2 Chemical Assay and Mineralogy

Duplicate chemical assays were conducted on the six composite samples, on the Master Composite, and on the Cluster 1 Composite (Table 13-1). Bulk Mineral Analyses via the QEMSCAN were also conducted to determine the mineral content of each sample.

Table 13-1: Head Assays Summary

Sample Description	Au	Ag	Fe	S <sub>TOTAL</sub>	C <sub>TOTAL</sub>	As	Total Organic Carbon*
	g/t	g/t	%	%	%	%	%
Master Composite	8.15	4	5.1	1.47	-	0.007	-
Cluster 1 – High	15.3	4	6.4	2.08	1.56	0.003	0.02
Cluster 1 – Average	6.28	1	6.4	1.72	1.76	0.002	0.02
Cluster 1 – Cut-off	3.16	1	6.3	1.49	1.59	0.003	0.02
Cluster 2 – High	14.6	3	4.1	1.57	1.04	<0.002	0.05
Cluster 2 – Average	6.14	2	4.5	1.20	1.02	<0.002	0.02
Cluster 2 – Cut-off	3.21	<1	4.0	0.99	0.79	<0.002	0.02
Cluster 1 Composite	8.66	-	6.3	1.97	-	-	-

The total sulphur content of the ore samples ranged from 1% to 2%. Sulphur was present primarily as pyrite with traces of chalcopyrite. Iron ranged from 4% to 6%. The Cluster 1 samples contained more pyrite and amphibole which explains the higher iron grades (6%).

The assays indicate 1% to 2% total carbon content but only a very small portion of it was present in the organic (elemental) form. The gangue minerals were primarily quartz and feldspars. The quartz content varied between 22% and 36% and the feldspars between 15% and 24%.

### 13.1.3 Metallurgical Test Program

The purpose of the test program was to establish a preliminary flowsheet. The program tested gravity concentration followed by cyanide leach of the gravity tailings as well as rougher flotation testing.

#### 13.1.3.1 Gravity Concentration and Cyanide Leach

There were four gravity concentration tests performed on the Master Composite, at different grind sizes (80% passing 130, 105, 79, and 56 µm), with a 3-inch Knelson laboratory centrifugal concentrator. The concentrate was then upgraded by hand-panning. Both the Knelson gravity concentration tailings and pan tailings were leached together in a 1,000 ppm sodium cyanide concentration at pH 11 for a 48-hour retention time. The highest overall gold recovery obtained was 89% at a 79 µm P<sub>80</sub> grind size.

The same procedure was applied to the six zone composite samples at a 75 µm P<sub>80</sub> grind size. These samples were subjected to three optimization tests as follows:

- Increase of the retention time from 48 to 96 hours
- Regrinding the Knelson concentrate to 50 µm P<sub>80</sub> and retention time of 96 hours
- Increase of the cyanide concentration to 5,000 ppm NaCN for the Cluster 1 samples.

A summary of the tests conditions and the recovery results is given in Table 13-2.

**Table 13-2: Gravity Concentration and Cyanide Leach - Conditions and Recoveries**

Test Conditions									
	Grind P <sub>80</sub> , µm	~ 75	~ 75	~ 75	~ 50				
	NaCN Concentration, mg/L	1000	5000	1000	1000				
	Retention Time, h	48	48	96	96				
	Gold Recoveries (%)	Gravity	Total	Gravity	Total	Gravity	Total	Gravity	Total
	Master Composite	23.0	89.0						
Cluster 1	Low Grade	12.3	81.0	18.5	86.8	18.4	88.7	20.3	91.6
	Average	22.8	84.3	24.4	90.0	25.1	88.9	26.2	92.2
	High Grade	14.8	79.3	17.3	86.4	16.4	87.5	20.9	91.1
Cluster 2	Low Grade	27.7	92.6			37.8	97.4	38.5	97.8
	Average	31.6	94.3			29.9	96.9	44.3	98.2
	High Grade	36.1	93.0			30.2	97.1	44.3	98.3

There was a notable difference in the performance of the Cluster 1 and Cluster 2 samples. Gravity and leach recoveries were better for Cluster 2. Depending on the test conditions, the total gold recovery ranged from 79% to 92% for Cluster 1 and from 93% to 98% for Cluster 2. In both cases, recovery increased with both the fineness of grind and retention time.

Increasing the leach retention time to 96 hours with the same cyanide concentration increased the overall recovery. Increasing the sodium cyanide concentration to 5,000 ppm, with a 48-hour leaching time, also increased the overall recovery.

### 13.1.3.2 Rougher Flotation

Rougher flotation tests were completed on the Master Composite and the three Cluster 1 samples. The objective was to evaluate the viability of incorporating flotation into the overall process.

Samples were ground to a target grind size P<sub>80</sub> of 130 µm. Flotation was conducted in a 4.4 L laboratory flotation cell with Potassium Amyl Xanthate (PAX) as collector and Methyl Isobutyl Carbonyl (MIBC) as frother. As summarized in Table 13-3, gold recoveries ranged between 82% and 90% at mass pulls ranging between 11% and 14%.

**Table 13-3: Summary of Flotation Gold Recoveries Obtained**

Sample	% Gold Recovery	% Mass Recovery
Master Composite	89%	11%
Cluster 1 – High	88%	14%
Cluster 1 – Average	90%	14%
Cluster 1 – Cut-off	82%	13%

### 13.1.3.3 Flotation, Regrind, and Cyanidation

Testing consisted of a rougher sulfide flotation using PAX as collector, MIBC as frother, at natural pH. The flotation concentrate was then regrind to a P<sub>80</sub> of 7 µm. The concentrate and tails were leached for 48 hours, with 5,000 ppm sodium cyanide for the concentrate and 1,000 ppm for the tails. The Cluster 1 Composite was

submitted to rougher flotation at three grind sizes. Total gold recovery increased from 93.6% at a 206 mm grind to 96.0% at a grind of 107  $\mu\text{m}$ .

### 13.1.4 Alternative Flowsheet Tests

A third series of metallurgical tests was undertaken in 2013 to compare the potential metallurgical results of four different flowsheets. These flowsheets were as follows:

- Flowsheet 1: Gravity and CIL
- Flowsheet 2: Whole ore cyanidation
- Flowsheet 3: Whole ore cyanidation and CIL
- Flowsheet 4: Flotation followed by cyanidation of concentrate and flotation tailings.

A new set of composites were prepared according to their zone of origin (Fortune, Parallel, Triangle, and Plug No. 4) with blended grades. Assays were performed on duplicate head cuts from each of the four composites and then the selected flowsheets were tested. All were tested with a primary grind size of 80% passing 75  $\mu\text{m}$ .

### 13.1.5 Properties of the Zone Composites

Table 13-4 shows a summary of the head sample assays. The gold grade varies from 4.5 g/t to 9.1 g/t, depending on the ore zone.

**Table 13-4: Summary of Chemical Assays**

Composite	Assays					
	Cu	Zn	Ag	S <sub>TOTAL</sub>	S <sup>2-</sup>	Au
	%	%	g/t	%	%	g/t
Fortune	0.024	0.03	4	1.11	1.08	6.3
Parallel	0.029	0.02	3	1.49	1.46	9.1
Triangle	0.009	0.01	5	1.58	1.54	8.8
Plug 4	0.011	0.01	2	1.78	1.74	4.5

Note: Gold assays were completed using a screened metallic assay method

### 13.1.6 Metallurgical Performance

There were 10 kg of each composite ore sample fed into a batch Knelson gravity concentrator with hand-panning of the gravity concentrate for upgrade. Tailings from gravity concentration and upgrade were submitted to a carbon-in-leach test under the following conditions: 30 g/L of activated carbon, 1,000 ppm of sodium cyanide, pH 11 and 96-hour retention time.

For the second and third flowsheets, the same conditions were applied to each flowsheet, with 1,000 ppm sodium cyanide, pH 11, and 96-hour retention time. However, for the third flowsheet, 30 g/L of activated carbon was added to the leach slurry.

Flotation (rougher and cleaner) was carried out at a natural pH with PAX as the collector and with MIBC as the frother. The final concentrate recovered, totalling about 3% to 4% of the feed mass, was leached with a 2,000 ppm concentration of sodium cyanide and pH 11 for a period of 96 hours. The flotation tailings were also leached with a 1,000-ppm sodium cyanide concentration, at the same pH and retention time. Table 13-5 presents the results that were obtained.

Table 13-5: Gold Recovery by Flowsheet

Gold Recovery (%)				
Composite	Flowsheet 1 Gravity-CIL	Flowsheet 2 Whole Ore Leach	Flowsheet 3 Whole Ore CIL	Flowsheet 4 Float- Leach
Plug 4	87.6	83.2	85.1	82.4
Triangle	93.0	92.9	93.4	91.9
Parallel	97.8	97.1	96.6	94.7
Fortune	96.6	95.6	97.1	95.1

Overall gold recoveries from the first three flowsheets were comparable. With these flowsheets, gold recoveries from the Parallel, Triangle, and Fortune composites ranged from 93% to 98% and recovery for the Plug 4 composite varied from 83% to 88%.

Flowsheet 4, using flotation, showed lower recoveries compared to the other three flowsheets. Leaching of the concentrate recovered between 58% to 86% of the feed gold. Leaching of the flotation tailings recovered an additional 9% to 24% of the feed gold.

## 13.2 Triangle Composite Testwork

In 2016, SGS conducted a series of metallurgical tests on samples from the Triangle deposit to characterize the hardness and the achievable gold recovery using the Sigma mill process flowsheet. Two composite samples were produced: one for the Supérieur (upper Triangle) portion of the deposit and the other for the Inférieur (lower Triangle) deposit area.

### 13.2.1 Chemical Analyses

Chemical analyses and screen metallic fire assay results are summarized in the Table 13-6.

Table 13-6: Triangle Zone Composites Head Assays Summary

Sample Description	Head Grade		+ 150 mesh			- 150 mesh			Cu %	S <sub>2</sub> - %	TOC %
	Au	Ag	Weight	Au	Ag	Weight	Au	Ag			
	g/t	g/t	g	g/t	g/t	g	g/t	g/t			
Supérieur	5.94	< 2.0	26.79	7.45	< 5.0	982.91	5.90	2.1	0.007	0.91	0.07
Inférieur	9.41	3.1	26.33	21.34	5.7	960.97	9.09	3.0	0.009	1.46	0.09

### 13.2.2 Acid Generation Potential

The Supérieur and Inférieur composites were found to be non-acid generating and analysis of the leach liquor did not find any acid generating elements to be present in significant concentration.

### 13.2.3 Grindability Testing

Grindability tests characterized the Supérieur and Inférieur composites as hard in terms of the Bond Rod Mill Work Index (averaging 17 kWh/t), moderately hard in terms of Bond BWi (averaging 15.8 kWh/t), and moderately abrasive (averaging 0.25).

### 13.2.4 Metallurgical Test Program

Gravity separation and cyanidation tests were performed on the three composites to verify the metallurgical performance expected in the Sigma processing plant. The overall gold recovery results for the gravity and cyanidation process are presented in Table 13-7. For the Triangle composite, overall gold recovery averaged 93.3% at a P<sub>80</sub> of 71 µm and increased to an average of 94.9% at a P<sub>80</sub> of 49 µm.

**Table 13-7: Overall Gold Recovery Summary**

Composite	P <sub>80</sub>	Gold Extraction (%)			Gold Head Grade (g/t)		Gold Grade CN Residue (g/t)
		Gravity	CN Leach	Overall	Calc.	Direct	
Inférieur G-1 + CN1	72	24.3	90.0	92.4	9.07	9.41	0.69
Supérieur G-2 + CN2	74	33.6	87.6	91.7	5.87	5.94	0.49
Triangle G-3 + CN3	49	34.9	91.7	94.6	7.76	-	0.42
Triangle G-3 + CN4			92.0	94.8			0.41
Triangle G-3 + CN5			92.3	95.0			0.39
Triangle G-3 + CN6			92.4	95.1			0.38
Triangle G-4 + CN7	49	34.6	92.6	95.2	8.09	-	0.39
Triangle G-5 + CN8	71	30.8	90.4	93.4	7.84	-	0.52
Triangle G-5 + CN9			90.2	93.2			0.54

### 13.2.5 Gold Deportment Study on Cyanidation Residue

A microscopic gold deportment study was performed on the combined residue from cyanidation tests CN3, CN4, and CN5. The study showed that the main gold mineral is calaverite (AuTe<sub>2</sub>), with moderate amounts of petzite (Ag<sub>3</sub>AuTe<sub>2</sub>) and native gold, accounting for 65%, 19%, and 15%, respectively. Based on the study, 39% of the microscopic gold particles (>0.5 µm) were liberated or exposed while 61% were present as locked gold particles. The major host minerals for exposed and locked gold were found to be pyrite (69%) and apatite (30%).

### 13.2.6 Cyanide Destruction

Cyanide destruction testwork using the SO<sub>2</sub>/air process, with sodium metabisulphite as the SO<sub>2</sub> source, was conducted on the residue from test CN7. The addition of 6.92 g SO<sub>2</sub>/g CN<sub>WAD</sub> (Weak Acid Dissociable (WAD) Cyanide), 3.23 g lime/g CN<sub>WAD</sub> and 0.08 g Cu/g CN<sub>WAD</sub>, were sufficient to achieve a final concentration of < 1.0 mg/L CN<sub>WAD</sub> with a retention time of 84 minutes.

## 13.3 Triangle Zone Testwork

In November 2017, Bureau Veritas (BV) commenced a metallurgical test campaign on samples from the Triangle deposit and rod mill feed samples collected during the first bulk sample campaign of Triangle ore that was being toll processed at the Camflo Mill.

### 13.3.1 Sample Preparation and Head Assays

A total of eight different Triangle deposit samples made up of coarse assay rejects were collected from zones C1, C2, C4, and C5 and composited to form a C2 composite, a C4 composite, and a Master Composite as summarized in Table 13-8. Analytical characterization follows in Table 13-9.

**Table 13-8: Assembly of Composite Samples**

Composite	Assembly
C2 composite (30 kg)	10 kg C2 Upper
	10 kg C2 Mid
	10 kg C2 Lower
C4 composite (30 kg)	10 kg C4 Upper
	10 kg C4 Mid
	10 kg C4 Lower
Master composite (80 kg)	10 kg C1
	10 kg C2 Upper
	10 kg C2 Mid
	10 kg C2 Lower
	10 kg C4 Upper
	10 kg C4 Mid
	10 kg C4 Lower
10 kg C5	

**Table 13-9: Selected Head Assays from Triangle Deposit Samples**

Composite	SG (g/cm <sup>3</sup> )	Au (Fire Assay) (g/t)	Au (Screened Metallics Procedure) (g/t)	Hg (g/t)	S <sub>TOTAL</sub> (%)	S <sub>2</sub> (%)	C <sub>TOTAL</sub> (%)	C <sub>INORG</sub> (%)	Cu (g/t)
Master	2.84	7.13	5.73	0.25	1.79	1.42	1.78	1.47	96
C2	2.84	5.07	6.11	0.74	1.8	1.39	2.01	1.69	108.7
C4	2.82	8.06	7.73	0.05	2.02	1.63	1.48	1.21	120.1
C1	2.79	5.93	7.67	0.08	0.65	0.33	1.72	1.47	169.1
C2 Upper	2.85	3.91	5.63	0.1	1.69	1.3	2.08	1.73	167
C2 Mid	2.84	3.59	5.72	1.08	1.59	1.18	1.65	1.3	55
C2 Lower	2.81	6.25	6.73	0.29	2.3	1.75	2.36	2.02	136.7
C4 Upper	2.84	8.94	9.07	0.04	2.05	1.64	1.7	1.43	101.1
C4 Mid	2.77	6.48	7.56	0.09	1.75	1.37	1.17	0.94	50.8
C4 Lower	2.83	6.07	5.80	0.02	2.3	1.81	1.66	1.37	172.5
C5	2.84	8.14	8.22	0.01	2.21	1.69	1.85	1.52	113.3
C2 Core	2.82	4.37	6.25	0.27	1.83	1.4	1.84	1.52	108.6
C4 Core	2.89	7.37	8.18	0.14	2.32	1.86	1.4	1.16	85.4

### 13.3.2 Comminution Testwork

Comminution tests were carried out on some of the composite samples, variability samples, and a bulk sample taken from the feed to the Camflo Mill while it was toll-milling Triangle ore. The results are summarized in Table 13-10 and Table 13-11.

**Table 13-10: Rod Mill and Ball Mill Work Indexes**

Sample	RWi (kWh/t)	BWi (kWh/t)	Ai (g)
C2 core	15.8	12.7	0.206
C4 core	17.8	13.1	0.170
Camflo composite	18.1	12.7	0.123

**Table 13-11: Ball Mill Work Index Variability Samples**

Sample	Ball Mill Work Index (kWh/t)
Master Composite	12.9
C2 Composite	12.4
C4 Composite	13.1
C1	13.4
C2 Upper	11.5
C2 Mid	13.0
C2 Lower	11.2
C4 Upper	12.8
C4 Mid	13.3
C4 Lower	13.5
C5	13.0

BWi testing was completed on five drill core samples, at a closing screen of 75 µm. Results are summarized in **Error! Not a valid bookmark self-reference..**

**Table 13-12: Bond Ball Mill Work Index Drill Core Results**

Sample ID	Bond Ball Mill Work Index (BWi, kWh/t)
C4 Diluted	17.1
Waste C5 Tuf	18.5
Waste C5 Dyke	20.0
C5 Diluted Tuf	16.4
C5 Diluted Dyke	16.6

### 13.3.3 Whole Ore Cyanidation

Whole ore cyanidation tests were conducted on the C2, C4, and Master composites to determine the impact on recovery of various parameters such as grind size, pH, lead nitrate, cyanide concentration, and aeration using oxygen or air. Some tests were also conducted on the Camflo composite to compare with results obtained at the Camflo plant.

All tests included 4 hours of pre-aeration. The samples were then submitted to a cyanide leach for a given duration (varies depending on test series) followed by CIP with 15 g/L activated carbon for 8 to 16 hours depending on the test series.

### 13.3.3.1 Baseline Tests

Baseline tests were carried out with the following conditions:

- P<sub>80</sub> of 50 µm
- 1.0 g/L NaCN
- 40% solids pulp density
- pH 10.5 - 11.0
- Aeration using oxygen (but DO levels achieved were only between 9.0 – 12.9 mg/L, with most values below 10)
- Leach duration: 56 hours
- CIP duration: 16 hours (total 72 hours)

Tests results are shown in Table 13-13. Recovery for the C2 composite was somewhat lower than for the C4 composite, with 90.9% compared to 94.2%. In addition, cyanide consumptions are much higher than those measured during the SGS tests with pre-aeration.

**Table 13-13: Baseline Leach Test Results**

Sample	Measured Head	Calculation Head	Residue	Leach Recovery (%)			CIP Recovery (%)	Reagent Consumption (kg/t)	
	g Au/t	g Au/t		24 h	48 h	56 h	72 h	NaCN	CaO
Master composite	6.43	7.26	0.409	89.9	90.6	92.1	94.3	1.31	1.36
C2 composite	5.59	6.46	0.585	84.5	87.3	88.2	90.9	1.41	1.39
C4 composite	7.90	7.57	0.447	92.9	93.2	92.8	94.2	1.38	1.17

Note: Average of fire assay and screened metallics procedure, Consumption after 56 hours, prior to carbon addition, Amount added. Residual not subtracted

### 13.3.3.2 Effect of Lead Nitrate, pH and Dissolved Oxygen

Recovery obtained during toll milling at the Camflo Mill was higher than what was observed in the lab test results. The Camflo Mill employed high pH and lead nitrate, so additional tests were conducted to determine the effect of lead nitrate addition and higher pH on Triangle ores.

The addition of lead nitrate or increasing the pH both improved recoveries. The recovery improvement was higher when the pH was maintained between 11.7 and 12.5. The highest pH levels also resulted in the lowest cyanide consumptions, whether lead nitrate was added or not.

The impact of high pH and lead nitrate on recovery can possibly be explained by the presence of gold tellurides. Both have been reported in the literature to improve gold telluride leaching rates (J.O. Marsden and C. I. House, 2006). Gold tellurides were identified as the main gold species in the cyanidation tailings in the SGS gold deportment study on the cyanidation residue. Other gold mines in the Val d'Or area have operated at high pH to improve gold telluride dissolution kinetics and gold recovery.

### 13.3.3.3 Effect of Grind Size

The effect of grind size was investigated at the highest pH (saturated with lime) and the addition of 1.5 kg/t lead nitrate. Cyanide concentration and pulp density were kept same as in the baseline tests.

Finer grinds led to higher recoveries, with about a 2% increase going from a  $P_{80}$  of 75  $\mu\text{m}$  to a  $P_{80}$  of 50  $\mu\text{m}$  at the tested retention times.

#### 13.3.3.4 Effect of Cyanide Concentration

Tests to determine the impact of cyanide concentration were conducted on the Master composite. Tests were conducted at 80% passing 47-48  $\mu\text{m}$  grind size, at high pH (11.0 – 12.3), with 1.5 kg/t lead nitrate addition and at high DO levels (> 20 mg/L). Pulp density remained at 45% solids as in the baseline tests.

Lower cyanide concentrations resulted in slower kinetics and reduced cyanide consumption. The effect on final recovery was however not clear from the tests.

#### 13.3.3.5 Variability Tests

There were two series of variability tests that were conducted, one with oxygen keeping the dissolved oxygen concentration above 20 mg/L, and the other with air.

Both series of tests were conducted under the following conditions:

- 80% passing 50  $\mu\text{m}$  grind size
- 1.0 g/L NaCN concentration
- 45% solids pulp density
- 1.5 kg/t lead nitrate
- 4 hours pre-aeration retention time and 32 hours leach retention time
- 16 hours CIP retention time (total 48 hours) with 15 g/L activated carbon

Although the intent was to conduct the tests at a  $\text{pH} \geq 11.7$ , lime consumption resulted in pH dropping to lower values during the tests. In the test series with oxygen, which was done first, pH values for the C1, C2, C4, and C5 ore samples dropped to around 10.6 to 10.8 after 24 hours. In the test series with air, pH was originally adjusted to higher values in an effort to maintain the  $\text{pH} \geq 11.7$  but nonetheless dropped to around 11.2 to 11.4 after 24 hours.

Test results for C1, C2, C4, and C5 ore samples are presented in Table 13-14. As can be seen from the results for the C1, C2, C4, and C5 ore samples, the higher pH in the test series with air resulted in systematic higher recoveries and lower cyanide consumptions, showing that the pH has a much higher impact than the dissolved oxygen concentration. Based on comparison with previous test results with  $\text{pH} \geq 11.7$ , it is believed that even higher recoveries could have been achieved if the pH had been maintained above this value throughout the leach.

In general, no variability sample stood out with results considerably different from the composite ore samples. C2 Upper performed slightly better than C2 Mid and C2 Lower. C1 showed particularly good recoveries but this is probably at least partially due to the high calculated head grades. Nonetheless, C1 residue grades were lower than for all other samples. C5 recoveries were similar to those of the C2 zone.

Table 13-14: C1, C2, C4 and C5 Ore Samples Variability Test Results

Sample	O <sub>2</sub> /air	pH	Measured Head <sup>1</sup>	Calculation Head	Residue	Recovery	Reagent Consumption (kg/t)	
			g Au/t	g Au/t	g Au/t	%	NaCN <sup>2</sup>	CaO <sup>3</sup>
C1	O <sub>2</sub>	10.6-12.3	6.80	9.94	0.207	97.9	0.43	2.91
	Air	11.2-12.9		10.90	0.209	98.1	0.29	3.66
C2 Upper	O <sub>2</sub>	10.6-12.2	4.77	6.55	0.437	93.1	0.36	2.91
	Air	11.3-12.7		6.44	0.370	94.0	0.28	3.51
C2 Mid	O <sub>2</sub>	10.6-12.3	4.65	5.92	0.563	90.4	0.41	2.63
	Air	11.2-12.8		6.71	0.420	93.3	0.28	3.24
C2 Lower	O <sub>2</sub>	10.6-12.2	6.49	6.56	0.595	90.5	0.49	2.77
	Air	11.3-12.8		7.32	0.506	92.7	0.27	3.38
C4 Upper	O <sub>2</sub>	10.6-12.3	9.01	9.30	0.609	93.4	0.39	2.92
	Air	11.2-12.8		9.78	0.513	94.8	0.23	3.68
C4 Mid	O <sub>2</sub>	10.6-12.3	7.02	7.68	0.332	95.6	0.39	2.88
	Air	11.4-12.8		9.89	0.458	95.0	0.24	3.48
C4 Lower	O <sub>2</sub>	10.8-12.3	5.94	7.36	0.433	93.9	0.36	2.97
	Air	11.4-12.7		7.15	0.377	94.6	0.22	3.57
C5	O <sub>2</sub>	10.7-12.3	8.18	9.17	0.729	91.9	0.39	3.03
	Air	11.3-12.8		9.46	0.633	93.1	0.22	3.48
C2 core	O <sub>2</sub>	10.6-12.3	5.31	6.07	0.527	91.2	0.56	2.75
	Air	11.0-12.8		6.03	0.356	93.9	0.22	3.36
C4 core	O <sub>2</sub>	10.7-12.3	7.78	7.28	0.375	94.8	0.47	2.91
	Air	11.4-12.9		8.61	0.301	96.5	0.16	3.27

Note: Average of fire assay and screened metallica procedure Consumption after 32 hours, prior to carbon addition Amount added. Residual not subtracted.

### 13.3.4 Cyanide Destruction Testwork

Continuous cyanide destruction tests were conducted in two 1.5 L reactors in series each with a 60-minute retention time. The tests were operated for 6 hours. Air feed to each reactor was 1.5 L/min. Based on the amount of copper already in the solution, various amounts of copper sulphate were added to reach the predetermined test copper concentrations. Sodium metabisulfite (Na<sub>2</sub>S<sub>2</sub>O<sub>5</sub>) was used as the source of SO<sub>2</sub>.

At a SO<sub>2</sub>/CN<sub>WAD</sub> ratio of 4.5 and a pulp density of 45% solids, residual CN<sub>WAD</sub> concentrations below 1.0 mg/L were achieved in the first reactor at both pH 8.0 and 9.0. At a pulp density of 55% solids, the concentration out of the first reactor slightly exceeded 1.0 mg/L CN<sub>WAD</sub>.

### 13.3.5 Thickening, Rheology and Filtration Testwork

Pocock Industrial of Salt Lake City, Utah, conducted solid-liquid separation (SLS) tests at Bureau Veritas' laboratory on three samples from the Master composite: Leach feed, CIP tailings, and cyanide destruction tailings, all at a P<sub>80</sub> grind size of 50 µm. Samples characteristics are shown in Table 13-15. Settling, rheology, and filtration tests were completed.

**Table 13-15: Solids Liquid Separation Testing Sample Characteristics**

Sample	Liquor S.G.	Solids S.G.	pH
50 µm Leach feed	1.00	2.83	11.7
50 µm CIP tailings	1.00	2.83	11.8
50 µm Detoxed tailings	1.00	2.83	9.3

### 13.3.5.1 Thickening Tests

Based on flocculant screening tests, SNF AN910SH, a medium to high molecular weight, 15% charge density anionic polyacrylamide, was selected with dosages of 10 g/t to 15 g/t for the leach feed and CIP tailings and 15 g/t to 20 g/t for the detoxed tailings.

Static and dynamic thickening tests were carried out, in both cases samples were diluted to a selected feed solids concentration using decant solution or simulated process solution. Recommended thickening design parameters for both conventional and high-rate thickeners (from static and dynamic tests) are summarized in Table 13-16.

**Table 13-16: Recommended Thickening Design Parameters**

Sample	Floc. Dosage (g/t)	Floc. Conc. (g/L)	Max Feed Solids Conc. (%)	Conventional Thickener Sizing <sup>1</sup> (m <sup>2</sup> /mtpd)	High-Rate Thickener Sizing (m <sup>3</sup> /m <sup>2</sup> ·h)	Estimated Underflow Density (%)
Leach feed	15 - 20	0.1 – 0.2	Conv. type: 15 - 25 High rate: 16 - 21	0.174	3.48	Conv. type: 61 - 65 High rate: 63 - 67
CIP tailings	20 - 25	0.1 – 0.2	Conv. type: 15 - 25 High rate: 16 - 21	0.172	3.68	Conv. type: 61 - 65 High rate: 63 - 67
Detoxed tailings	20 - 25	0.1 – 0.2	Conv. type: 15 - 25 High rate: 16 - 21	0.175	3.22	Conv. type: 61 - 65 High rate: 63 - 67

Note: Includes a 1.25 scale up factor.

### 13.3.5.2 Rheology Tests

Pulp rheology of the non-Newtonian thickener underflow pulps was measured using a Fann Model 35A true coaxial cylindrical rotational viscometer. Underflow slurries were pre-sheared (i.e., the flocculant structure destroyed) using a laboratory mixer prior to testing.

A summary of the apparent viscosities at reference shear rates and varying percent solids is presented in Table 13-17. The thickener underflow slurries exhibit a shear thinning behavior with apparent viscosity decreasing as shear increases.

Yield stresses required to initiate flow are also indicated in the table. Underflow slurries with yield stress values in excess of 30 N/m<sup>2</sup> (Pa) are normally beyond the capabilities of conventional thickening and pumping systems. In addition, the shape of the yield stress versus solids concentration curve must also be considered. Design density should be selected such as to avoid the exponential region of the curve as the material could quickly become solidified beyond pumping capability with only a slight increase in solids concentration.

**Table 13-17: Thickener Underflow Apparent Viscosities and Yield Stress**

Sample	Solids Conc. %	Coefficient of Rigidity Pa·s	Yield Stress N/m <sup>2</sup>	Apparent Viscosity (Pa·s)								
				5 s-1	25 s-1	50 s-1	100 s-1	200 s-1	400 s-1	600 s-1	800 s-1	1000 s-1
Leach Feed	69.3	0.178	55.1	7.334	2.685	1.742	1.130	0.733	0.475	0.369	0.308	0.268
	67.6	0.139	44.0	5.759	2.157	1.413	0.925	0.606	0.397	0.310	0.260	0.227
	65.4	0.085	31.8	2.935	1.364	0.981	0.705	0.507	0.365	0.301	0.262	0.236
	62.5	0.045	19.7	1.883	0.832	0.586	0.412	0.290	0.204	0.166	0.144	0.128
	58.0	0.024	9.4	0.954	0.422	0.297	0.209	0.147	0.103	0.084	0.073	0.065
	49.1	0.018	4.1	0.516	0.232	0.165	0.117	0.083	0.059	0.048	0.042	0.037
CIP Tailings	68.8	0.184	56.6	7.389	2.715	1.764	1.146	0.745	0.484	0.376	0.314	0.274
	67.9	0.152	48.0	5.997	2.295	1.518	1.004	0.664	0.439	0.345	0.290	0.254
	66.0	0.086	34.9	4.330	1.566	1.011	0.652	0.421	0.272	0.210	0.175	0.152
	63.1	0.074	19.5	2.960	1.037	0.660	0.420	0.268	0.170	0.131	0.108	0.094
	57.0	0.019	6.8	0.875	0.321	0.209	0.136	0.088	0.057	0.044	0.037	0.032
	49.1	0.006	2.1	0.287	0.100	0.063	0.040	0.025	0.016	0.012	0.010	0.009
Detoxed Tailings	68.7	0.209	57.4	6.062	2.743	1.949	1.385	0.984	0.699	0.573	0.497	0.445
	67.0	0.129	42.5	4.459	1.976	1.392	0.981	0.691	0.487	0.396	0.343	0.306
	65.4	0.092	30.4	3.255	1.443	1.017	0.716	0.504	0.355	0.290	0.250	0.224
	62.5	0.048	15.5	1.911	0.751	0.502	0.336	0.224	0.150	0.119	0.100	0.088
	58.7	0.030	7.1	1.132	0.409	0.263	0.170	0.110	0.071	0.055	0.046	0.040
	49.9	0.012	2.4	0.414	0.149	0.096	0.062	0.040	0.026	0.020	0.016	0.014

### 13.3.6 Vacuum Filtration Tests

Vacuum filtration tests were conducted using a filter leaf supported vertically on a vacuum flask. The filter cloth used was a National Filter Media (NFM) 8-10 cfm/ft<sup>2</sup> multifilament polypropylene cloth. All tests were conducted at an applied vacuum of 67.7 kPa. No flocculant was added as filtration aid.

There were two samples that were tested, unthickened detoxed tailings and thickened detoxed tailings. Vacuum filtration tests were performed to examine the effect of cake thickness and air-dry duration on production rate and filter cake moisture, as listed in Table 13-18.

**Table 13-18: Summary of Vacuum Filtration Test Results**

Sample	Feed Solids Conc.	Cake Thickness	Filter Cake Moisture	Bulk Cake Density	Production Rate <sup>1</sup>
	%	mm	%	dry kg/m <sup>3</sup>	dry kg/m <sup>2</sup> ·h
Unthickened detoxed tailings	42.2	10	19.6%	1412	570
		15	20.4%		495
Thickened detoxed tailings	64.3	10	17.6%	1523	1248
		15	18.5%		1582

Note: Production rate includes a 0.8 scale up factor

### 13.3.7 Pressure Filtration Tests

Pressure filtration tests were conducted in a lab scale pressure filtration device consisting of a 250 mm section of a 50 mm pipe with drainage grid supporting the filter media in the lower flange. NFM 8-10 cfm/ft<sup>2</sup> multifilament polypropylene cloth was used. Pressure applied during the tests was 550 kPa.

Tests were conducted on the two same samples as for vacuum filtration. Tests were performed to examine the effect of cake thickness, air blow duration, and air blow on sizing requirements and filter cake moisture. Results are summarized in Table 13-19.

**Table 13-19: Summary of Pressure Filtration Test Results**

Sample	Feed Solids Conc.	Half Cake Thickness	Filter Cake Moisture	Bulk Cake Density	Bulk Cake Density	Sizing Basis <sup>1</sup>	Air Blow Time	Total Filter Cycle Time
	%	mm	%	dry kg/m <sup>3</sup>	wet kg/m <sup>3</sup>	m <sup>3</sup> /dry tonne	min	min
Unthickened detoxed tailings	42.3	15	14.5%	1231	1440	1.016	3.0	16.0
Thickened detoxed tailings	64.3	15	9.8%	1608	1783	0.777	3.0	16.0

Note: Includes a 1.25 scale up factor

### 13.4 Comminution Testwork

Comminution testwork was carried out by SGS in 2019 through 2020. A run-of-mine (ROM) ore sample from the Triangle C2 zone, as well as three ore samples from the Triangle C4 zone (East, Lower, and Upper) were tested, with results summarized in Table 13-20.

**Table 13-20: Comminution Testing Results**

Sample	Relative Density	JK Parameters				Work Indices (kWh/t)			Ai
		A × b <sup>1</sup>	A × b <sup>2</sup>	T <sub>a</sub>	SCSE	CWI	RWI	BWI	(g)
ROM (C2)	2.79	39.7	39.1	0.44	10.1	11.5	15.1	14.7	0.225
C4 – East	2.92		29.7	0.26	12.1	-	-	15.7	-
C4 – Lower	2.82		34.0	0.31	11.0	-	-	16.3	-
C4 – Upper	2.80		34.7	0.32	10.8	-	-	18.0	-

The testwork was primarily carried out to provide a basis for modeling potential mill expansions beyond the current rod mill-ball mill circuit at the Sigma mill. Significant milling expansion scenarios are not considered within the current evaluation; therefore, these simulations are not detailed here.

### 13.5 Lower Triangle (Zones C8 through C10) and Ormaque

Additional testwork was carried out at BV in 2020 on six composite samples generated from coarse assay rejects. The composites were from Triangle zones C8 through C10, the Triangle stockwork zone, and from the Ormaque deposit.

Each of the composite samples was stage crushed to 100% passing 6 mesh, with a sub-sample split for BWI testing. The samples were then crushed to 10 mesh and a representative 30 kg sub-samples split out for extended gravity recoverable gold (E-GRG) testing with the remainder rotary split into 1 kg test charges. A summary of assay results from the composites is found in Table 13-21.

Table 13-21: Summary of Selected Head Assay Results

Analyte	Unit	C8+C8B Composite	C9 Composite	C9B Composite	C10 Composite	Stockwork Composite	Ormaque Composite
Au	g/t	6.48	6.58	7.39	8.03	3.32	10.50
Au – Duplicate	g/t	6.17	6.59	6.40	8.12	2.40	8.14
Au – Average	g/t	6.33	6.59	6.90	8.08	2.86	9.32
Ag	g/t	3.0	3.0	3.0	4.0	2.0	3.0
S <sub>total</sub>	%	1.69	1.73	2.45	1.72	1.30	2.22
S <sup>2-</sup>	%	1.68	1.71	2.43	1.71	1.35	2.20
C <sub>total</sub>	%	1.51	1.47	1.76	1.44	0.72	0.93
C <sub>org</sub>	%	0.24	0.22	0.30	0.21	0.08	0.12
Hg	Ppm	0.04	<0.01	<0.01	<0.01	<0.01	0.02
Te	Ppm	6.6	6.8	6.6	8.0	3.9	8.9
SG	g/cm <sup>3</sup>	2.74	2.75	2.78	2.75	2.71	2.73

### 13.5.1 Comminution Testing

BWI testing was completed on the six composites, at a closing screen of 105 µm. Results are summarized in Table 13-22. The Ormaque composite was slightly softer than the other composites tested from lower Triangle.

Table 13-22: Bond Ball Mill Work Index Results

Composite ID	Test ID	Bond Ball Mill Work Index (BWi, kWh/t)
C8 + C8B Composite	BWi-1	13.3
C9 Composite	BWi-2	13.0
C9B Composite	BWi-3	12.8
C10 Composite	BWi-4	13.5
Stockwork Composite	BWi-5	12.7
Ormaque Composite	BWi-6	11.8

### 13.5.2 CIP Leach Tests

Baseline CIP tests were carried out at three different primary grinds (P<sub>80</sub> of 35 µm, 50 µm, and 65 µm). Slurry was pre-aerated at 45% pulp density with oxygen sparging for 4 hours. The slurry was then leached in 1 g/L NaCN for 78 hours. Subsequently, 15 g/L of pre-attritioned and washed activated carbon was added and leaching continued for an additional 18 hours.

Baseline CIP results corresponding to the current plant target grind P<sub>80</sub> of 35 µm are summarized in Table 13-23. It was noted that the calculated head grades were consistently higher than the measured head grades. Screen (metallics) fire assays should be used for future testwork to improve the level of precision in gold determination.

Table 13-23: Selected Carbon-In-Pulp Results, Baseline 35 mm P<sub>80</sub>

Test ID	Composite ID	Measured Head Au (g/t)	Calculated Head Au (g/t)	CIP Extraction (%)	Final Residue Grade Au (g/t)	NaCN Consumption (kg/t)	Ca(OH) <sub>2</sub> Consumption (kg/t)
CIP-1	C8 + C8B Composite	6.33	7.52	93.7	0.53	2.63	5.8
CIP-2	C9 Composite	6.59	6.61	93.6	0.47	2.49	5.6
CIP-3	C9B Composite	6.90	7.35	94.2	0.45	2.67	5.6
CIP-4	C10 Composite	8.08	9.64	94.9	0.53	2.70	5.6
CIP-5	Stockwork Composite	2.86	4.12	93.1	0.31	2.44	5.4
CIP-6	Ormaque Composite	9.32	10.48	97.3	0.42	2.49	5.6

As shown in Figure 13-1, all the composites exhibited grind sensitivity across the grind sizes tested. The Ormaque composite yielded higher recoveries and was less sensitive to grind size.

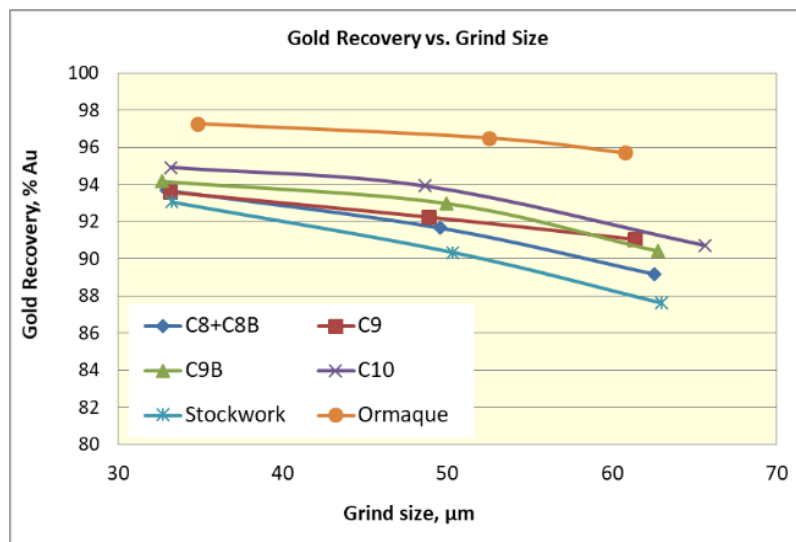

Figure 13-1: Grind Size vs Gold Recovery

### 13.5.3 Carbon-In-Pulp Optimization Tests

A series of CIP optimization tests was carried out on the C8 + C8B composite. Several variables were varied, including the use of lead nitrate, pre-aeration, air or oxygen in pre-aeration, and slurry pH. In all cases, the optimization tests yielded lower recovery than the baseline condition.

### 13.5.4 Extended Gravity Recoverable Gold Tests

A series of E-GRG tests were carried out to assess gravity-recoverable gold at four stages of size reduction: 10 mesh, 250 µm, 75 µm, and 40 µm. Results are found in Table 13-24, with a summary of the first two stages of recovery taken as an indicator of potential plant gravity gold recovery.

Table 13-24: Selected E-GRG Results

Test ID	Composite ID	Stage 1 Recovery (%)	Stage 2 Recovery (%)	Stage 3 Recovery (%)	Stage 1+2 Mass Pull (%)	Stage 1+2 Au Grade (g/t)	Stage 1+2 Au Recovery (%)
EGRG-1	C8 + C8B	12.8	12.4	9.9	0.9	222.9	25.2
EGRG-2	C9	14.4	9.1	14.6	0.9	157.8	23.5
EGRG-3	C9B	15.5	11.5	11.2	1.0	208.0	27.0
EGRG-4	C10	15.7	12.6	11.3	1.0	290.1	28.3
EGRG-5	Stockwork	20.0	10.0	9.7	0.9	141.5	30.0
EGRG-6	Ormaque	21.2	13.5	12.6	1.0	383.4	34.7

The Ormaque composite exhibited a higher proportion of gravity-recoverable gold than the Triangle composites.

### 13.5.5 Gold Deportment Study

A gold deportment study was carried out on leach tailings from two of the CIP tests on the C8 + C8B composite. QEMSCAN / MLA analysis indicated that more than 75% of the gold present in the tailings was in the form of gold-bearing telluride minerals.

These include calaverite ( $\text{AuTe}_2$ ), petzite ( $\text{Ag}_3\text{AuTe}_2$ ), and sylvanite ( $(\text{Au,Ag})\text{Te}_2$ ). The presence of these minerals in the leach tails is in line with conventional knowledge regarding slower leach kinetics for gold telluride minerals.

## 13.6 Ormaque Metallurgical Testwork

A metallurgical testwork campaign was initiated in 2021, with a focus on samples from the recently discovered Ormaque deposit.

### 13.6.1 Sample Description

Interval samples of quarter-split core have been used for this testwork program; supplemented by coarse assay rejects corresponding to the same drill intervals. The sample descriptions are summarized in Table 13-25. Sub-splits of each variability sample were combined to form an additional Ormaque composite.

Table 13-25: Ormaque Metallurgical Samples

Sample ID	Zone	Drill Hole	From (m)	To (m)	Expected Au (g/t)
ORM-1	OR1	LS-19-009_R	395.00	407.40	5.06
ORM-2	OR1	LS-21-046	386.00	394.30	4.91
ORM-3	OR5	LS-21-055	300.45	310.00	5.54
ORM-4	OR5	PV-18-031	336.00	347.50	6.46
ORM-5	OR5	LS-20-030A	273.25	282.80	4.46
ORM-6	OR5	LS-20-039B	264.00	268.50	5.61
ORM-7	OR6	LS-19-008	245.10	251.10	5.48
ORM-8	OR15	LS-19-009_R	499.00	514.00	6.57

Additionally, three host rock samples adjacent to the mineralization were samples to assess the comminution characteristics expected from waste rock as summarized in Table 13-26.

**Table 13-26: Host Rock (Waste) Samples**

Sample ID	Rock Type	Drill Hole	From (m)	To (m)
Waste-1	I2JC	LS-21-053	269.5	274.8
Waste-2	OR15	LS-19-009_R	367.0	381.0
Waste-3	OR1	LS-20-038	515.0	526.4

### 13.6.2 Head Characterization

Head assays on the eight variability samples and the Ormaque composite sample, are summarized in Table 13-27.

**Table 13-27: Head Characterization of Ormaque Samples**

	Unit	ORM-1	ORM-2	ORM-3	ORM-4	ORM-5	ORM-6	ORM-7	ORM-8	Ormaque Composite
<b>SG</b>	g/cm <sup>3</sup>	2.73	2.70	2.70	2.66	2.69	2.70	2.70	2.73	2.71
<b>Au (FA)</b>	g/t	7.96/ 6.38	3.36	4.46	5.37	3.09	4.15	3.87	6.55	4.28
<b>Au (SM)</b>	g/t	4.60	2.90	4.84	4.76	2.85	4.12	3.07	6.17	4.09
<b>Ag</b>	g/t	3.1	2.8	2.9	3.0	2.7	3.3	2.8	3.3	3.0
<b>S<sub>TOT</sub></b>	%	1.49	1.25	1	0.4	0.92	1.17	0.96	1.16	1.07
<b>S<sup>2-</sup></b>	%	1.19	0.94	0.74	0.22	0.6	0.83	0.7	0.84	0.77
<b>S<sub>SO4</sub></b>	%	0.30	0.32	0.26	0.18	0.32	0.34	0.26	0.32	0.30
<b>C<sub>TOT</sub></b>	%	0.72	1.45	0.93	0.72	0.59	0.78	0.81	0.92	0.85
<b>C<sub>INORG</sub></b>	%	0.66	1.36	0.85	0.65	0.55	0.71	0.74	0.84	0.79
<b>C<sub>ORG</sub></b>	%	0.06	0.09	0.08	0.06	0.04	0.06	0.07	0.07	0.06
<b>Te</b>	ppm	2.0	3.4	4.0	2.4	1.6	4.4	2.3	4.9	2.5
<b>Cu</b>	ppm	70.1	113.9	42.4	102.5	602.9	151.1	9.6	135.1	160.6

There is an appreciable difference between the conventional and screen metallic fire assay determinations for gold. This is reflective of the presence of coarse gold, which can lead to a nugget effect.

### 13.6.3 Mineralogical Analysis

Quantitative mineralogical phase analysis was completed using X-ray diffraction with Rietveld refinement. The results, summarized in Table 13-28, indicate relatively minor quantities of pyrite and somewhat higher concentrations of calcite.

**Table 13-28: XRD Characterization of Ormaque Samples**

Mineral	ORM-1	ORM-2	ORM-3	ORM-4	ORM-5	ORM-6	ORM-7	ORM-8
Quartz	35.2	34.2	35.8	37.2	35.6	31.8	32.1	40.8
Plagioclase	15.3	7.7	23.0	18.5	15.7	18.3	23.2	1.7

Mineral	ORM-1	ORM-2	ORM-3	ORM-4	ORM-5	ORM-6	ORM-7	ORM-8
Calcite	6.0	9.6	7.8	5.7	5.4	6.6	7.1	7.1
Ankerite	-	2.1	-	-	-	-	-	0.4
Pyrite	2.9	2.5	1.9	0.8	1.7	2.3	1.9	2.2
Muscovite	8.0	8.1	6.4	10.5	13.0	9.4	7.6	8.7
Dravite	6.2	12.6	3.6	4.5	4.9	8.6	1.9	8.9
Rutile	0.7	0.7	0.6	0.7	0.7	0.6	0.8	0.6
Paragonite	12.2	5.2	9.7	3.8	6.8	9.1	7.9	15.9
Chamosite	13.5	17.2	11.2	18.4	16.2	13.4	17.3	13.8

### 13.6.4 Comminution Testwork

Comminution testwork was carried out on the Ormaque composite as well as the three waste rock samples. Results are found in Table 13-29 and Table Table 13-30.

**Table 13-29: Ormaque Composite Comminution Results**

Sample ID	SMC Test Results						RWi (kWh/t)	BWi (kWh/t)	Ai (g)
	A×b	DWi (kWh/m <sup>3</sup> )	Mia	Mih	Mic	SCSE (kWh/t)			
Ormaque Composite	23.9	11.9	29.5	24.5	12.7	13.2	18.3	14.2	0.08

The A × b value obtained by the SMC test for the Ormaque composite of 23.9 indicates that the sample would be very hard in terms of SAG milling competency (top 4% of tests in the SMC database). Similarly, the rod mill index results indicate the ore to be relatively hard at the coarser grind sizes with respect to the more moderate ball mill work indices.

**Table 13-30: Ormaque Waste Rock Grindability Results**

Sample ID	Rock Type	Drill Hole	RWi (kWh/t)	BWi (kWh/t)
Waste-1	I2JC	LS-21-053	18.4	14.6
Waste-2	OR15	LS-19-009_R	20.7	13.3
Waste-3	OR1	LS-20-038	18.6	14.4

### 13.6.5 Gravity Testwork

A four-stage E-GRG test was carried out the Ormaque composite, with stages corresponding to P<sub>80</sub> grind sizes of 951 µm, 222 µm, 71 µm, and 39 µm. The results are summarized in Table 13-31 and indicate that cumulatively 48% of the gold was recovered to a gravity concentrate representing a mass pull of 1.81% and assaying 161 g/t Au.

**Table 13-31: Extended Gravity Recoverable Gold (E-GRG) Results**

Stage	P <sub>80</sub> (µm)	Mass (%)	Au (g/t)	Au Recovery (%)
1	951	0.44%	209.79	15.1%
2	222	0.47%	209.22	16.1%

Stage	P <sub>80</sub> (µm)	Mass (%)	Au (g/t)	Au Recovery (%)
3	71	0.44%	93.54	6.8%
4	39	0.47%	131.57	10.1%
Total		1.81%	161.14	48.1%
Stage 1 + Stage 2		0.91%	209.5	31.2%

### 13.6.6 Variability Testwork

The Ormaque variability samples were subjected to testwork aimed to mimic the current process flowsheet at the Sigma mill. This included initial grinding and removal of a gravity concentrate followed by continued grinding to a P<sub>80</sub> target of 40 µm. Overall results are summarized in Table 13-32.

**Table 13-32: Ormaque Variability Cyanidation Results**

Test ID	Sample ID	P <sub>80</sub> (µm)	NaCN (g/L)	Measured Head Au (g/t)	Calc. Head Au (g/t)	Recovery			Consumption		
						Gravity (%)	Leach (%)	Total (%)	Residue Au (g/t)	NaCN (kg/t)	Lime (kg/t)
GC1	ORM-1	38	0.424	5.89	5.25	10.6	85.8	96.4	0.19	0.81	1.53
GC2	ORM-2	39	0.424	3.13	3.89	9.2	82.6	91.7	0.32	0.70	1.69
GC3	ORM-3	41	0.424	4.65	5.30	10.0	77.1	87.2	0.68	0.88	1.41
GC4	ORM-4	41	0.424	5.06	4.94	26.1	72.3	98.4	0.08	0.83	1.47
GC5	ORM-5	37	0.424	2.97	3.41	7.3	81.5	88.8	0.38	0.85	1.49
GC6	ORM-6	35	0.424	4.13	5.05	4.0	90.0	94.0	0.30	0.79	1.42
GC7	ORM-7	40	0.424	3.47	3.98	9.1	88.2	97.3	0.11	0.86	1.29
GC8	ORM-8	41	0.424	6.36	8.48	13.7	79.5	93.1	0.58	0.90	1.54

The average recoveries for the Ormaque variability samples were 93.4%, ranging between 88.8% and 97.3%. The average final residue grade was 0.33 g/t, ranging between 0.11 g/t and 0.58 g/t. This is slightly higher than the average tail grade of approximately 0.20 g/t currently seen in the mill. Sampling was carried out during the leach time, with resulting kinetic leach curves found in Figure 13-2. Following completion of optimization testwork on the Ormaque composite, additional tests of the individual variability samples may be carried out to verify improvements in recovery.

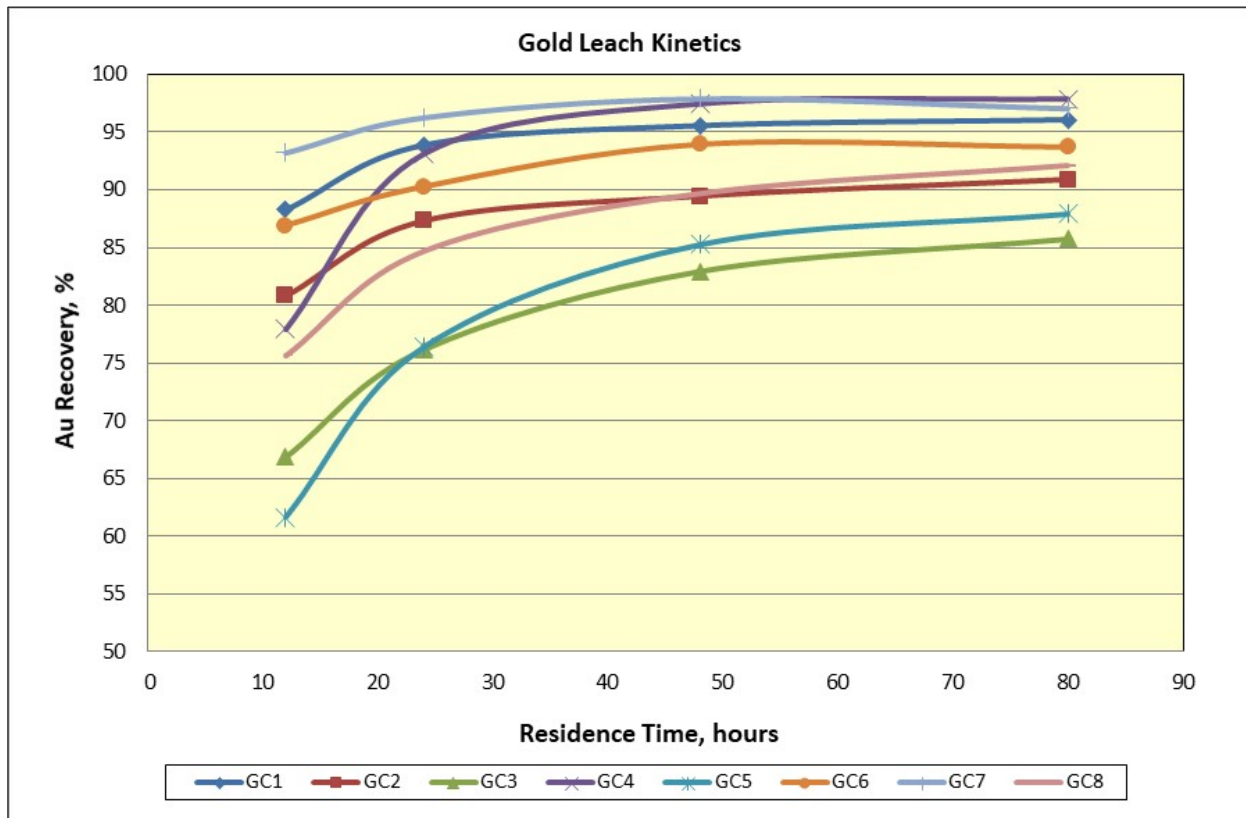

Figure 13-2: Leach Kinetics for Ormaque Variability Samples

### 13.6.7 Optimization Testwork

A series of optimization tests were carried out on the Ormaque composite, with varying grind size, pH, cyanide concentration, and temperature. Results are summarized in Table 13-33.

Table 13-33: Ormaque Composite Optimization Results

Test ID	P <sub>80</sub> (µm)	pH	CN (mg/L)	Temp (°C)	Measured Head Au (g/t)	Calc. Head Au (g/t)	Recovery			
							Gravity (%)	Leach (%)	Total (%)	Residue Au (g/t)
GC9	74	11.2	225	25	4.18	4.94	17.6	73.5	91.1	0.440
GC10	61	11.2	225	25	4.18	5.19	23.4	69.4	92.8	0.375
GC11	51	11.2	225	25	4.18	6.15	18.7	75.3	94.0	0.371
GC12	25	11.2	225	25	4.18	5.49	23.6	71.8	95.4	0.254
GC13	39	10.7	225	25	4.18	6.46	27.3	67.7	95.1	0.318
GC14	39	12.2	225	25	4.18	4.91	21.8	74.7	96.5	0.174
GC15	39	11.2	225	15	4.18	5.13	18.6	76.7	95.3	0.241
GC16	39	11.2	225	40	4.18	6.05	18.0	79.6	97.6	0.144
GC17	39	11.2	350	25	4.18	5.61	25.0	70.9	96.0	0.227
GC18	39	11.2	150	25	4.18	4.85	18.9	72.8	91.7	0.403
BGC-1	38	11.2	225	25	4.18	5.33	20.0	75.1	95.2	0.258

The results of the optimization testwork indicate a range of recoveries between 91.1% and 97.6%, confirming the expected relationships between higher recoveries and finer grinds, higher recoveries at higher pH, and higher recoveries at higher cyanide dosages. Based on observed differences in seasonal recoveries, temperature was also varied and showed to correlate higher recoveries with higher temperature. As illustrated in Figure 13-3, the highest recoveries correspond to a grind size of 39  $\mu\text{m}$  or finer, pH of 12.2, and cyanide dosage of 350 mg/L. Temperature was varied in the laboratory, but it is not considered to be a variable that could be directly controlled in the mill.

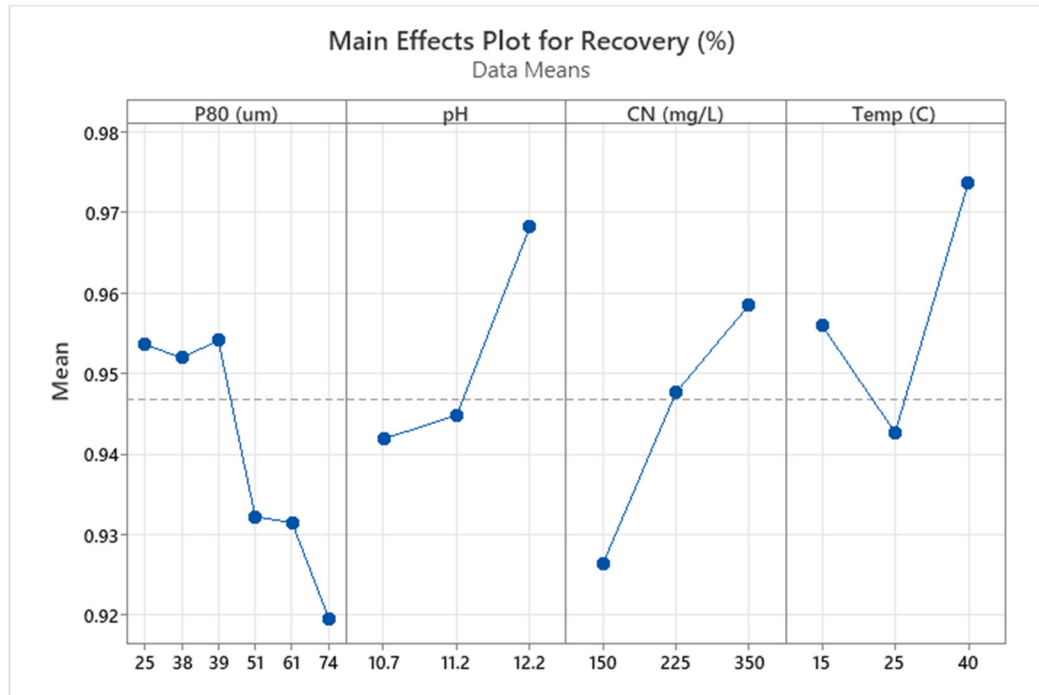

Figure 13-3: Impact of Principal Variables on Ormaque Composite Recovery

### 13.6.8 Alternative Flowsheets

Bulk sulfide flotation followed by cyanidation of reground flotation concentrate and as-produced flotation tailings was carried out at primary grinds at a  $P_{80}$  of 75  $\mu\text{m}$  and 60  $\mu\text{m}$ . The overall recovery was 87.0% at a primary grind of 75  $\mu\text{m}$  and 87.3% at a primary grind of 60  $\mu\text{m}$ , which is considerably lower than the recoveries obtained through the current flowsheet.

### 13.6.9 Cyanide Detox

A confirmatory cyanide detox test using the  $\text{SO}_2$ /air method was carried out on the leach tailings from test BGC-1 on the Ormaque composite. This corresponded to the leach conditions closest to the current plant parameters. The test produced an effluent that assayed less than 0.1 mg/L total cyanide and less than 0.05 mg/L  $\text{CN}_{\text{WAD}}$ .  $\text{SO}_2$  consumption was 5.1 g per g total cyanide.

### 13.6.10 Acid Base Accounting Testing

Acid Base Accounting (ABA) testwork was carried out on the detoxified sample produced and described in Section 13.6.9. Results are summarized in Table 13-34, indicating that the tails are not expected to be acid-producing.

**Table 13-34: Acid Base Accounting Test Results**

Sample	Total Sulfur (%)	Sulfate Sulfur (%)	Fizz Rating	Paste pH	Acid Potential (kg CaCO <sub>3</sub> /t)	Neutralization Potential		
						Actual NP (kg CaCO <sub>3</sub> /t)	NP/AP Ratio	Net NP (kg CaCO <sub>3</sub> /t)
CD-1	1.09	0.27	Slight	8.5	25.6	69.7	2.72	44.1
CD-1 (duplicate)	1.05	0.27	-	-	24.4	69.7	2.86	45.3

### 13.6.11 Mineralogy and Gold Department

A mineralogical study was carried out on the Ormaque composite feed and leach tailings corresponding to a P<sub>80</sub> of 40 µm. The feed sample contained approximately 2% sulfide minerals, primarily pyrite with minor chalcopyrite and sphalerite. Gangue minerals identified included quartz, chlorite, plagioclase feldspar, muscovite, and kaolinite.

Approximately 70% of the gold contained in the feed composite hosted in native gold with the remainder hosted by gold-silver tellurides, namely calaverite (AuTe<sub>2</sub>), petzite (Ag<sub>3</sub>AuTe<sub>2</sub>), and sylvanite ((Au,Ag)Te<sub>2</sub>).

Leach recoveries were above 95%. In terms of losses to the tails, the gold hosted tellurides represented approximately two-thirds of the total gold.

### 13.6.12 Ormaque Bulk Sample Testing

The bulk sample of Ormaque ore was excavated during Q3 and Q4 and has been processed at the Sigma mill in December. A total of 36 358 tonnes was mined at a sampled grade of 14.93g/t using. Between December 2nd and December 12th, 28,405 tonnes were processed at the Sigma mill exclusively from the Ormaque deposit. Head grade was 15.26 g/t, producing 13,652 oz of gold with a recovery rate of 98.0%. Remaining material has been processed along with Triangle run-of-mine. Estimated grade from the resources model for the corresponding mining opening is 10.12 g/t

## 13.7 Results, Summary, and Conclusions

Ores that have been processed at the Sigma mill have yielded high metallurgical recovery but require a fine grind size to ensure sufficient liberation. The milling circuit is thus configured to achieve the targeted grind size.

A portion of the gold at upper Triangle, lower Triangle, and Ormaque is hosted with gold telluride minerals. To reduce gold losses to tails, leaching parameters have been optimized including pH and residence time. This has included the addition of two 2,500 m<sup>3</sup> leach tanks to maintain in excess of 70 hours of leach residence time. Process controls are used to ensure that optimal leaching conditions are maintained.

Coarse liberated gold that could otherwise lead to tails losses is recovered in a conventional gravity circuit.

The samples that have been tested from lower Triangle as well as from the Ormaque deposit display similar characteristics to the upper Triangle ore currently being processed and would be expected to provide comparable results when processed at the Sigma mill.

To the extent known, the test samples used for metallurgical testing are representative of the various types and styles of mineralization and the mineral deposit their respective zones as a whole, as described in this report.

Unless otherwise discussed in this report, to the extent known, there are no processing factors or deleterious elements that could have a significant effect on potential economic extraction

## 14 Mineral Resource Estimates

### 14.1 Triangle Deposit

#### 14.1.1 Introduction

The MRE for the Triangle deposit used data from both surface and underground diamond drillholes. The MREs were made from 3D block models created by utilizing Seequent Leapfrog Geo and Edge suite of software. The block parent model cell size is 5 m east by 5 m north by 5 m high and is then sub-blocked to 1 m east, 1 m north and a variable height between 0.1 m to 1 m.

#### 14.1.2 Mineralization Domains

Gold mineralization occurs within the moderately to steeply dipping main shear zones and associated more moderately dipping splays. The interpretation of all mineralized zones is underpinned by a geological review of structure, alteration and veining carried out by site geologists. The geological elements characterizing mineralized features were captured in a separate composite field which defined and labeled each mineralized zone. Subsequently, 3D mineralized domains were created using the vein modeling module in Seequent's Leapfrog Geo software from an interval selection largely based on the composite field. The selection was locally re-modelled to ensure spatial coherence and continuity in 3D, and resulting in the production of two sets of solids. The first were mineralization solids, which connect all similar intervals defined by the composite field, irrespective of grade; these solids track the geological elements supporting the mineralization, and the second were all resource solids, based on those created in step No. 1, which restrict / clip zones laterally by removing material below a resource cut-off grade of ~3 g/t Au. Due to the dense amount of drilling for C1, C2, C3-100, C3-70, C4, C4-01, C4-100, C4-70, C4-30, C5, C6-30, C6-80 and C7 zones, the mineralization solids were used for the estimation and reported within the resource shapes after the estimation.

At Triangle, 13 main shear zones were modelled (Figure 14-1). Of these, C4 is the largest and C3 is the smallest. Each of the main shear zones down to C6 has associated mineralized splay zones. Main and splay mineralization zones from C1 to C5 are referred to as upper Triangle; C6 to C10 are referred to as lower Triangle (Figure 14-1).

#### 14.1.3 Data Analysis

The mineralized domains were reviewed to determine appropriate estimation or grade interpolation parameters. Several different procedures were applied to the data. Descriptive statistics, histograms and cumulative probability plots and box plots have been completed for composite data. The results were used to guide the construction of the block model and the development of estimation plans including treatment of extreme grades. These analyses were conducted on 1 m composites of the assay data. The statistical properties from this analysis are summarized for both uncapped and capped data in Table 14-1 and Table 14-2 for the main Triangle deposit.

Gold grades in the Triangle deposit are highest in C4, C5, C8, C8B, C9B and C10 shear zones, followed by C2, C4 and C6, C8 and C9 splay veins. Coefficients of variation (CVs) for uncapped data are highest in the upper Triangle shears (>2.2), where more data is available. This highlights the importance of the nugget effect in an orogenic gold vein system.

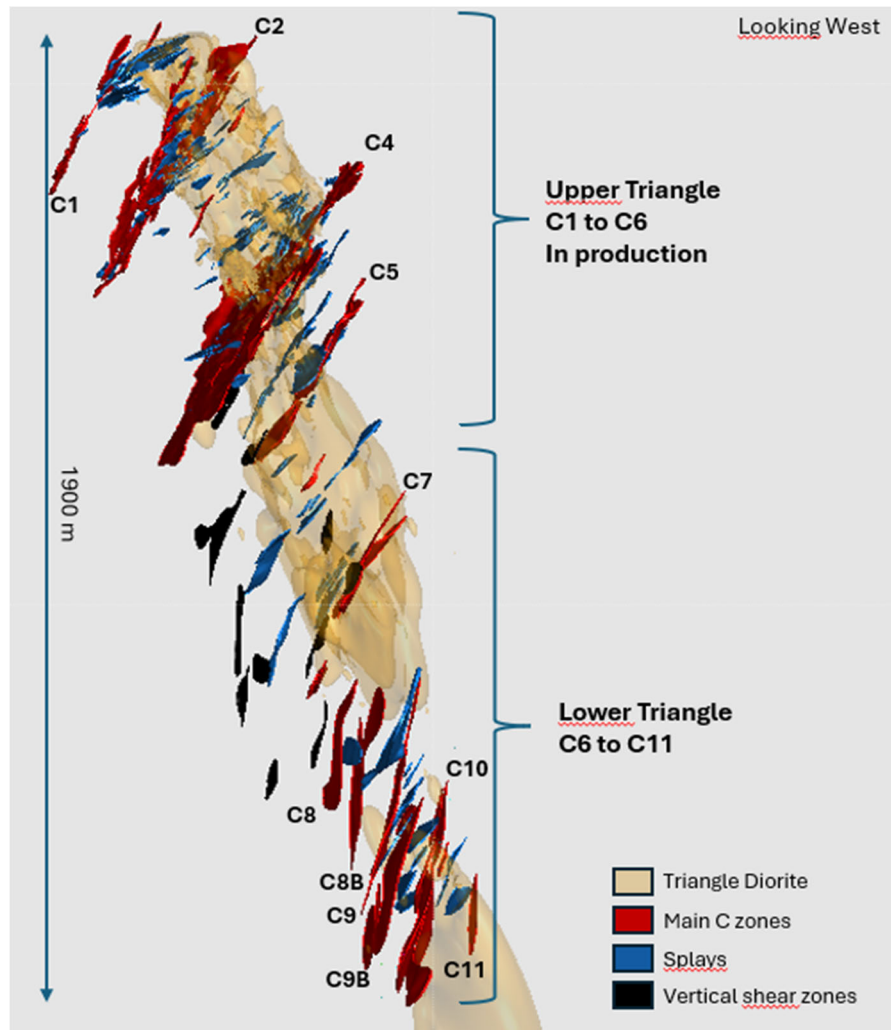

Figure 14-1: 3D View of the Modeled Resource Solids Associated with the Main Shear Zones and their Associated Splay Zones at Triangle (Eldorado 2024)

Table 14-1: Triangle Deposit Composite Statistics for 1 m Uncapped Composite Au (g/t) Data

Name	Count	Mean	SD	CV	Variance	Min	Q25	Q50	Q75	Max
C1	842	7.226	23.02	3.186	530.135	0.002	0.1278	0.9999	4.65	390.045
C2	6784	8.312	19.8799	2.391	395.21	0.002	0.5504	3.06	8.38	402.895
C3	60	9.38	21.31	2.27	454.3	0.02	0.64	3.16	7.39	137.76
C4	6758	10.76	26.04	2.42	677.87	0.002	1.03	4.07	10.57	911.25
C4-01	214	4.305	5.3558	1.243	28.685	0.002	0.12	2.41	6.69	29.11
C5	1029	10.51	21.059	2.004	443.48	0.002	1.7	5.17	11.2	328
C6	32	4.46	6.36	1.43	40.39	0.011	0.796	2.686	5.02	30.81
C7	185	7.74	15.45	1.996	238.84	0.002	0.7259	2.693	8.575	116.572
C8	38	5.94	6.198	1.04	38.42	0.005	0.664	2.918	9.329	22.728

Name	Count	Mean	SD	CV	Variance	Min	Q25	Q50	Q75	Max
C8B	36	11.57	21.159	1.83	447.7	0.002	1.466	4.75	9.36	102.94
C9	58	4.97	5.11	1.028	26.15	0.0052	1.314	3.55	5.9	22.002
C9B	72	6.64	9.93	1.49	98.65	0.005	1.176	3.575	8.616	57.094
C10	67	7.29	11.87	1.63	140.81	0.005	1.39	3.81	8.24	78.84
C10B	34	4.94	4.16	0.84	17.27	0.069	2.252	3.25	7.83	16.63
C10S	19	4.06	10.16	2.51	103.27	0.005	0.005	0.115	1.493	40.36
C11	11	5.78	8.03	1.39	64.52	0.795	1.97	3.62	8.02	35.07
C1 Splays	1318	6.078	12.25	2.02	150.18	0.002	0.76	2.9918	6.71	174.63
C2 Splays	649	954	38.4992	4.037	1482.19	0.002	0.4765	2.84857	7.7	798.466
C3 Splays	3659	6.966	18.602	2.67	346.03	0.002	0.4266	1.945	6.11	390.8
C4 Splays	4069	8.3	26.38	3.18	696.02	0.002	0.399	2.83097	8.01	749.223
C5 Splays	408	4.75	7.876	1.66	62.037	0.002	0.1392	1.952	6.16	67.115
C6 Splays	269	7.68	14.73	1.918	217.061	0.002	0.258	2.98	8.33	122.84
C7 Splays	36	3.28	4.26	1.3	18.12	0.015	0.112	1.65	5.03	16.791
C8 Splays	130	10.0664	34.28	3.41	1175.3	0.005	0.145	3.206	6.428	344.007
C9 Splays	124	10.47	17.04	1.63	290.41	0.006	1.298	5.46	12.88	133.394
C10 Splays	42	47.77	272.152	5.696	74066.5	0.014	1.147	3.104	6.553	1762.75

Note: Min = minimum value; Max = maximum value; Mean = average value; Q25 = value at the 25th frequency percentile of the data; Q50 = value at the 50th frequency percentile of the data, i.e., the median; Q75 = value at the 75th frequency percentile of the data; SD = standard deviation of the data; CV = Coefficient of Variation of the data and equals SD / Mean.

**Table 14-2: Triangle Deposit Composite Statistics for 1 m Capped Composite Au (g/t) Data**

Name	Count	Mean	SD	CV	Variance	Min	Q25	Q50	Q75	Max	Capping gpt
C1	842	6.024	14.0344	2.3297	196.964	0.002	0.12785	0.9999	4.65	100	100
C2	6784	7.325	12.4366	1.6976	154.668	0.002	0.5504	3.06	8.36	100	100
C3	62	7.21	11.99	1.66	143.85	0	0.624	2.9298	7.08	52.19	100
C4	6758	9.3278	15.074	1.616	227.236	0.002	1.0345	4.06	10.565	100	100
C4-01	214	4.305	5.355	1.243	28.685	0.002	0.12	2.41	6.69	29.11	80
C5	1029	9.23645	12.93	1.4	167.252	0.002	1.704	5.17	11.2	100	100
C6	32	4.46	6.36	1.43	40.39	0.011	0.796	2.686	5.021	30.81	80
C7	185	6.864	10.995	1.6	120.9	0.002	0.7259	2.693	8.575	66.72	80
C8	38	4.8	6.04	1.26	36.379	0.005	0.232	2.275	8.198	22.728	80
C8B	89	6.12	13.27	2.17	176.09	0	0	0.15	5.4	67.34	80
C9	58	4.97	5.11	1.03	26.15	0.004	1.314	3.55	5.9	22.002	80
C9B	72	6.55	9.64	1.47	92.9668	0.005	1.176	3.575	8.616	57.094	80
C10	67	7.116	10.888	1.43	118.555	0.005	1.3927	3.811	8.2357	68.414	80
C10B	34	4.94	4.16	0.84	17.266	0.069	2.252	3.25167	7.83478	16.6281	80
C10S	19	4.055	10.16	2.51	103.27	0.005	0.005	0.115	1.49	40.36	80
C11	11	5.78	8.03	1.39	64.52	0.795	1.97	3.62	8.02	35.07	80
C1 Splays	1318	5.66	8.79	1.55	77.29	0.002	0.76	2.99	6.71	80	80

Name	Count	Mean	SD	CV	Variance	Min	Q25	Q50	Q75	Max	Capping gpt
C2 Splays	649	6.75	12.06	1.79	145.51	0.002	0.48	2.85	7.546	80	80
C3 Splays	3659	5.83	10.69	1.83	114.282	0.002	0.426	1.945	6.097	80	80
C4 Splays	4069	6.68	10.83	1.62	117.21	0.002	0.399	2.83	8.01	80	80
C5 Splays	408	4.74	7.76	1.64	60.27	0.002	0.139	1.952	6.16	63.836	80
C6 Splays	269	7.01	11.17	1.59	124.97	0.002	0.26	2.98	8.33	73.6	80
C7 Splays	36	3.28	4.26	1.3	18.12	0.015	0.112	1.65	5.03	16.791	80
C8 Splays	130	6.46	10.53	1.63	110.82	0.005	0.175	3.206	6.428	56.225	80
C9 Splays	124	9.35	11.12	1.19	123.67	0.0062	1.298	5.46	12.88	47.44	80
C10 Splays	42	6.54	10.04	1.54	100.86	0.014	1.147	3.1038	6.553	42.9696	80

Note: Min = minimum value; Max = maximum value; Mean = average value; Q25 = value at the 25th frequency percentile of the data; Q50 = value at the 50th frequency percentile of the data, i.e., the median; Q75 = value at the 75th frequency percentile of the data; SD = standard deviation of the data; CV = Coefficient of Variation of the data and equals SD / Mean.

#### 14.1.4 Evaluation of Extreme Grades

The shear zones and associated splays at Triangle display effects due to extreme gold grades. As such, the data shows high CV values, especially in the upper Triangle zones. A strategy of capping extreme assay values to limit the risk associated with extreme grades was pursued. For purposes of capping, the probability of achieving or exceeding the predicted annual grade in the production schedule as a measure of risk was used. An 80% level of risk was chosen as acceptable. The 80% figure is the probability of achieving or exceeding the predicted annual contribution from the high grades. In other words, the actual contribution from the high grade should meet or exceed the prediction in 4 out of 5 years.

The procedure adopted establishes a capping grade through Monte Carlo simulation. It is assumed that mining will encounter the high grades in a more or less random or independent way. Therefore, the total number of high-grade samples likely to be encountered during the mining in any year is dependent on the mining rate and how frequently higher grades occur. The sample grades are then subdivided into low- and high-grade populations at an arbitrary value.

The 20<sup>th</sup> percentile of the distribution is selected as the risk-adjusted high-grade metal contribution. The analysis for the Triangle mineralized zones showed that a capping strategy should aim to remove about 11% of the gold metal in the estimate. This was achieved by implementing a cap to assay data prior to compositing, using a 100 g/t Au cap in C1, C2, C3, C4, and C5 main zones and a 80 g/t Au cap in the rest of the zones. The number of capped Triangle samples was 298, 196 in the main shear zones and 102 in the splay zones.

#### 14.1.5 Variography

Variography, a continuation of data analysis, is the study of the spatial variability between pairs of points at various distances. Variograms were calculated and modelled for gold within domains with large population of samples (C1, C2, C4, C4-01, C5, C3-70, C3-100, C4-30, C7). Variogram model parameters are shown in Table 14-3. Gold inside the shears displays high nugget effect and small ranged structures, typical of orogenic deposits.

**Table 14-3: Variogram Parameters for Triangle Zones**

Domain	C0	C1	Dip/Azi/Pitch	Range Mj/Sm/Mn	C2	Range Mj/Sm/Mn
C1	0.66	0.34	65.4/192.8/155.3	15.0/12.0/6.0		
C2	0.40	0.60	67.5/196.1/140.6	18.0/15.0/5.0		
C3-100	0.30	0.70	63.9/180.2/131.1	28.5/17.9/5.0		
C3-70	0.06	0.91	40.8/190.4/84.0	57.1/53.1/19.1		
C4-01	0.60	0.40	61.3/180.6/150.1	88.0/22.0/1.0		
C4-30	0.21	0.79	54.4/180.5/139.6	21.4/15.7/3.5		
C4	0.37	0.38	56.9/181.3/152.3	14.0/4.0/1.3	0.25	56.0/43.0/1.3
C5	0.39	0.61	58.1/187.9/163.1	35.0/16.0/1.2		

Note: Models are spherical.

### 14.1.6 Bulk Density

A constant bulk density of 2.8 t/m<sup>3</sup> was used for the Triangle deposit. This is based on measurements from earlier work and extensive experience in the Val-d'Or camp with similar deposits.

### 14.1.7 Model Set-up

Eldorado carried out the grade estimation using the Edge module of Leapfrog Geo software. The block size for the Triangle model was in part selected based on mining selectivity considerations (underground mining) and shown in Table 14-4.

The assays were composited into 1 m fixed length downhole composites, honoring the individual modelled main vein or splay vein 3D shape. Intervals of less than 0.5 m lengths were distributed equally into the preceding composites. A second set of composites of 5 m was created for model validation purposes.

All blocks were coded on a whole block basis by zone type, class and reportable resource. Mined openings as of September 30, 2024, were cut out from the resource shape and excluded from the final resource export.

**Table 14-4: Block Model Limits and Block Size**

	Base Point	Parent Block (m)	Sub-Block Count	No. of Parent Block	Boundary Size
East	295 973	5	5	239	1195
North	5328220	5	5	175	875
Elevation	367	5	Variable Height	388	1940

### 14.1.8 Estimation

Grade modelling consisted of interpolation by Ordinary Kriging (OK) and Inverse Distance Weighting (ID) to the second power with 1 m composites. Kriging was used for domains that have sufficient drilling, mainly in the upper triangle portion of the deposit; C1, C2, C4, C4-01, C5, C7, and splays C3-70, C3-100 and C4-30. Inverse distance interpolation was used for the remaining zones, largely due to the limited data in these domains. Nearest-neighbour (NN) grades were also interpolated for validation purposes but were interpolated using the 5 m composite data set. Blocks and composites were created within mineralized domains. Parameters for estimations are shown in Table 14-5.

For the interpolation in main zones from C1 to C10 (excluding C6 and C11), the maximum number of samples required for the interpolation varies between 15 and 20. For the remaining main zones, the maximum number

of samples required for interpolation was 20 to 25. The minimum number of samples required varies from 1 to 4 for the main zones and 1 for the splays. The number of samples, number of drillholes and the average distance of the samples used in estimation were stored during the interpolation. These items were used in the definition of mineral resource classification.

The search ellipsoids were oriented preferentially to the orientation of the respective domains as defined by the attitude of the modelled 3D shape and the ore shoot direction (if present). The sizes were somewhat guided by the results of the spatial analysis and visual validation.

**Table 14-5: Estimation for Triangle Domains**

Domain	Pass	Estimation	Search Radius		Nb of Samples			Drillhole Limit
			Mj	Sm	Mn	Min	Max	Max
C1	1	OK	20	15	8	4	18	2
	2	OK	30	20	10	4	18	2
	3	OK	60	40	15	1	20	4
C1-10	1	IDW2	90	54	18	1	20	NA
C1-100	1	IDW2	90	54	18	1	20	NA
C1-30	1	IDW2	90	54	18	1	20	NA
C1-40	1	IDW2	90	54	18	1	20	NA
C1-60	1	IDW2	90	54	18	1	20	NA
C1-62	1	IDW2	90	54	18	1	20	NA
C1-70	1	IDW2	90	54	18	1	20	NA
C1-90	1	IDW2	90	54	18	1	20	NA
C2	1	OK	25	20	6	4	18	2
	2	OK	32	24	8	4	18	2
	3	OK	50	30	12	1	18	4
C2-10	1	IDW2	90	54	18	1	20	NA
C2-100	1	IDW2	90	54	18	1	20	NA
C2-110	1	IDW2	90	54	18	1	20	NA
C2-20	1	IDW2	90	54	18	1	20	NA
C2-40	1	IDW2	90	54	18	1	20	NA
C2-50	1	IDW2	90	54	18	1	20	NA
C2-60	1	IDW2	90	54	18	1	20	NA
C2-70	1	IDW2	90	54	18	1	20	NA
C2-80	1	IDW2	90	54	18	1	20	NA
C2-90	1	IDW2	90	54	18	1	20	NA
C2S	1	IDW2	90	54	18	1	20	NA
C3	1	IDW2	41.61	51.73	21.18	1	6	5
C3-10	1	IDW2	90	54	18	1	20	NA
C3-100	1	OK	90	54	15	4	20	NA
C3-120	1	IDW2	90	54	18	1	20	NA

Domain	Pass	Estimation	Search Radius		Nb of Samples			Drillhole Limit
			Mj	Sm	Mn	Min	Max	Max
C3-130	1	IDW2	90	54	18	1	20	NA
C3-20	1	IDW2	120	120	18	1	20	NA
C3-30	1	IDW2	90	54	18	1	20	NA
C3-50	1	IDW2	90	54	18	1	20	NA
C3-60	1	IDW2	90	54	18	1	20	NA
C3-70	1	OK	120	80	18	4	20	NA
C3-80	1	IDW2	90	54	18	1	20	NA
C3-90	1	IDW2	90	54	18	1	20	NA
C3-95	1	IDW2	90	54	18	1	20	NA
C3-97	1	IDW2	90	54	18	1	20	NA
C3-98	1	IDW2	90	54	18	1	20	NA
C4	1	OK	30	8	3	4	18	2
	2	OK	45	12	5	4	18	2
	3	OK	60	25	12	1	12	4
C4-01	1	OK	60	30	2	4	18	NA
	2	OK	90	40	5	2	18	NA
	3	OK	100	50	8	1	18	NA
C4-04	1	IDW2	50	30	20	1	25	4
C4-07	1	IDW2	25	25	10	1	25	4
C4-09	1	IDW2	50	30	20	1	25	4
C4-10	1	IDW2	120	120	25	1	20	NA
C4-100	1	IDW2	120	75	40	1	20	NA
C4-11	1	IDW2	20.98	20.09	12.5	1	9	2
C4-12	1	IDW2	30	60	12.5	1	20	NA
C4-20	1	IDW2	90	54	18	1	20	NA
C4-30	1	OK	120	80	15	4	20	NA
C4-31	1	IDW2	90	54	18	1	20	NA
C4-32	1	IDW2	90	54	18	1	20	NA
C4-70	1	IDW2	100	100	30	1	20	NA
C4-80	1	IDW2	120	70	25	1	20	NA
C4-90	1	IDW2	120	120	40	1	20	NA
C5	1	OK	35	20	2	4	18	2
	2	OK	45	30	5	4	18	4
	3	OK	60	40	12	1	12	5
C5-10	1	IDW2	90	54	18	1	20	NA
C5-100	1	IDW2	90	54	18	1	20	NA
C5-110	1	IDW2	90	54	18	1	20	NA

Domain	Pass	Estimation	Search Radius		Nb of Samples			Drillhole Limit
			Mj	Sm	Mn	Min	Max	Max
C5-20	1	IDW2	90	54	18	1	20	NA
C5-30	1	IDW2	90	54	18	1	20	NA
C5-45	1	IDW2	90	54	18	1	20	NA
C6	1	IDW2	120	80	40	1	20	NA
C6-100	1	IDW2	90	54	18	1	20	NA
C6-20	1	IDW2	94	54	18	1	20	NA
C6-30	1	IDW2	94	54	18	1	20	NA
C6-40	1	IDW2	90	54	18	1	20	NA
C6-80	1	IDW2	80	80	50	1	20	5
C6-90	1	IDW2	90	54	18	1	20	NA
C6-95	1	IDW2	90	54	18	1	20	NA
C7	1	IDW2	100	80	15	2	20	4
C7-100	1	IDW2	90	54	18	1	20	NA
C8	1	IDW2	80	75	30	1	18	NA
C8-10	1	IDW2	90	54	18	1	20	NA
C8-30	1	IDW2	120	80	40	1	20	NA
C8B	1	IDW2	120	120	40	1	20	NA
C9	1	IDW2	120	80	40	1	20	NA
C9-05	1	IDW2	30	30	15	1	20	NA
C9-10	1	IDW2	45	45	15	1	20	NA
C9-20	1	IDW2	100	60	15	1	20	NA
C9-30	1	IDW2	100	100	15	1	20	NA
C9-40	1	IDW2	100	100	15	1	20	NA
C9-50	1	IDW2	60	35	15	1	20	NA
C9-80	1	IDW2	80	50	25	1	20	NA
C9B	1	IDW2	120	80	40	1	20	NA
C10	1	IDW2	90	90	50	1	18	NA
C10B	1	IDW2	100	100	40	1	20	NA
C10S	1	IDW2	80	60	25	1	20	NA
C10-10	1	IDW2	100	100	15	1	20	NA
C10-20	1	IDW2	60	40	15	1	20	NA
C11	1	IDW2	100	100	50	1	9	3

## 14.1.9 Validation

### 14.1.9.1 Visual Inspection

Eldorado completed a detailed visual validation of the Triangle resource models. They were checked for proper coding of drillhole intervals and block model cells, in both cross-section and plan views. Coding was

found to be accurate. Grade interpolation was examined relative to drill hole composite values by inspecting cross-sections and plans. The checks showed good agreement between drill hole composite values and model cell values. The hard boundaries appear to have constrained grades to their respective estimation domains. The addition of the outlier restriction values succeeded in minimizing grade smearing in regions of sparse data. Examples of representative sections containing block model grades, drill hole composite values, and domain outlines are shown in Figure 14-2 to Figure 14-4.

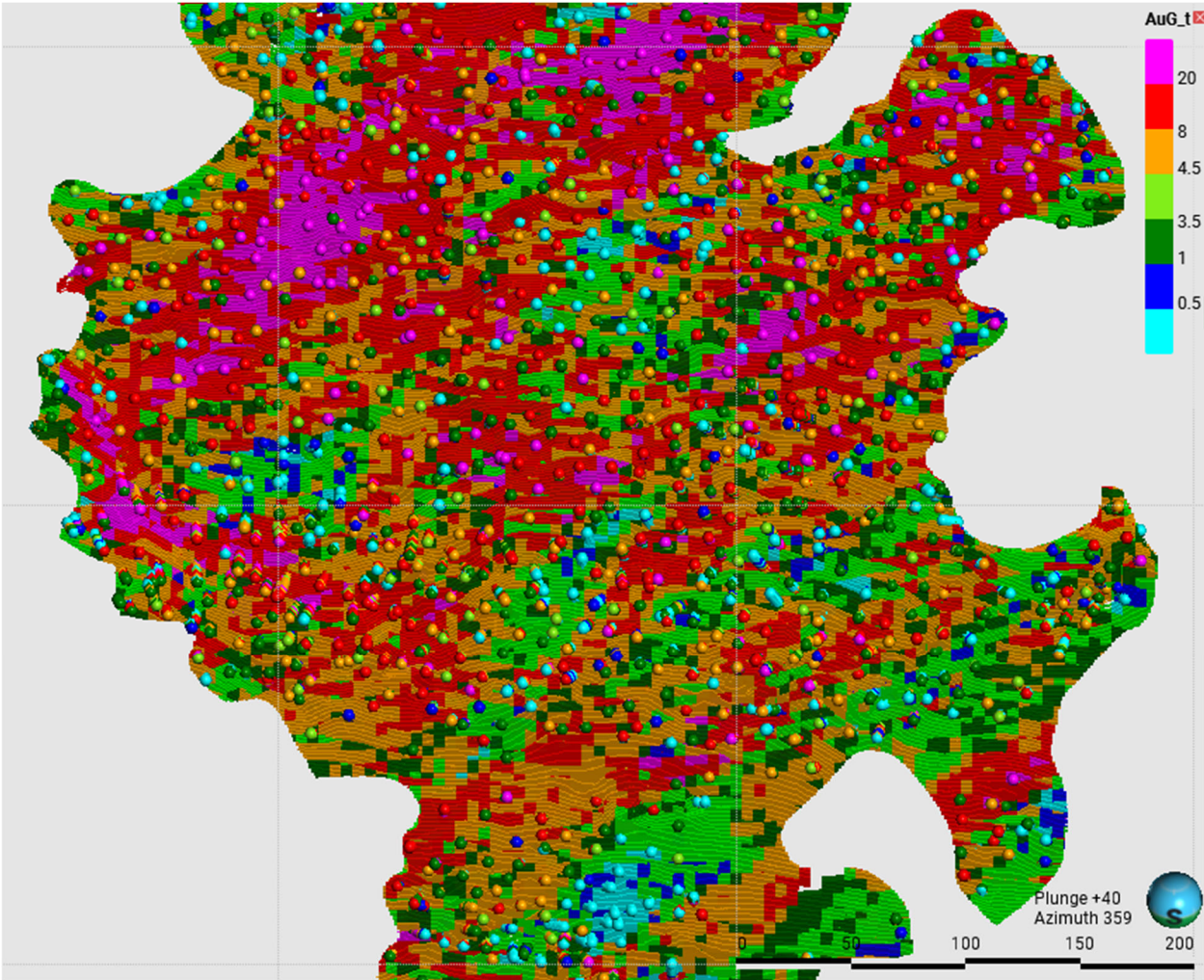

Figure 14-2: Lower Central Portion of C4 Zone Showing Block Model Grade and Composites (Eldorado 2024)

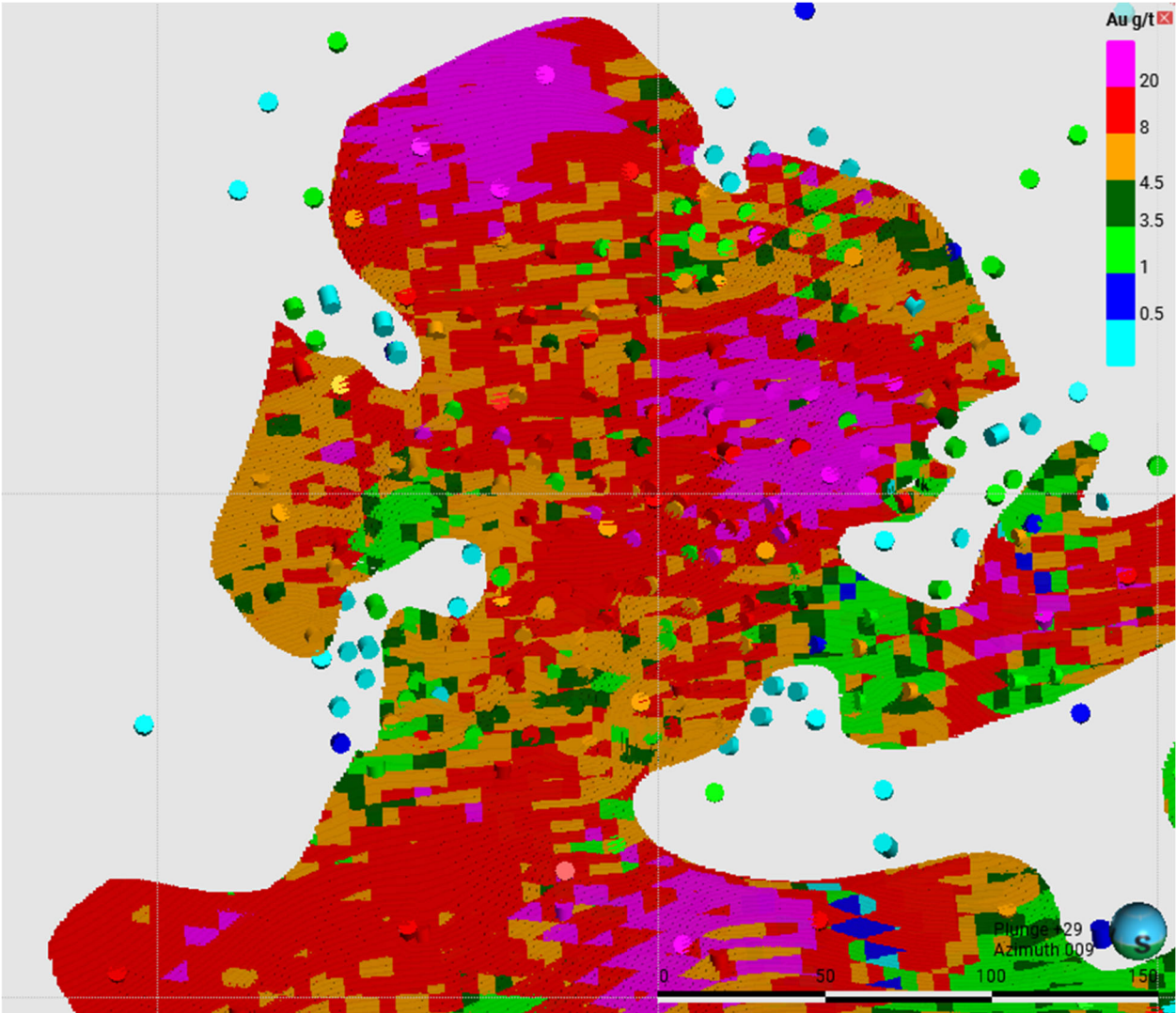

Figure 14-3: Upper Portion of C5 Shear Zone Showing Block Model Grades and Composites (Eldorado 2024)

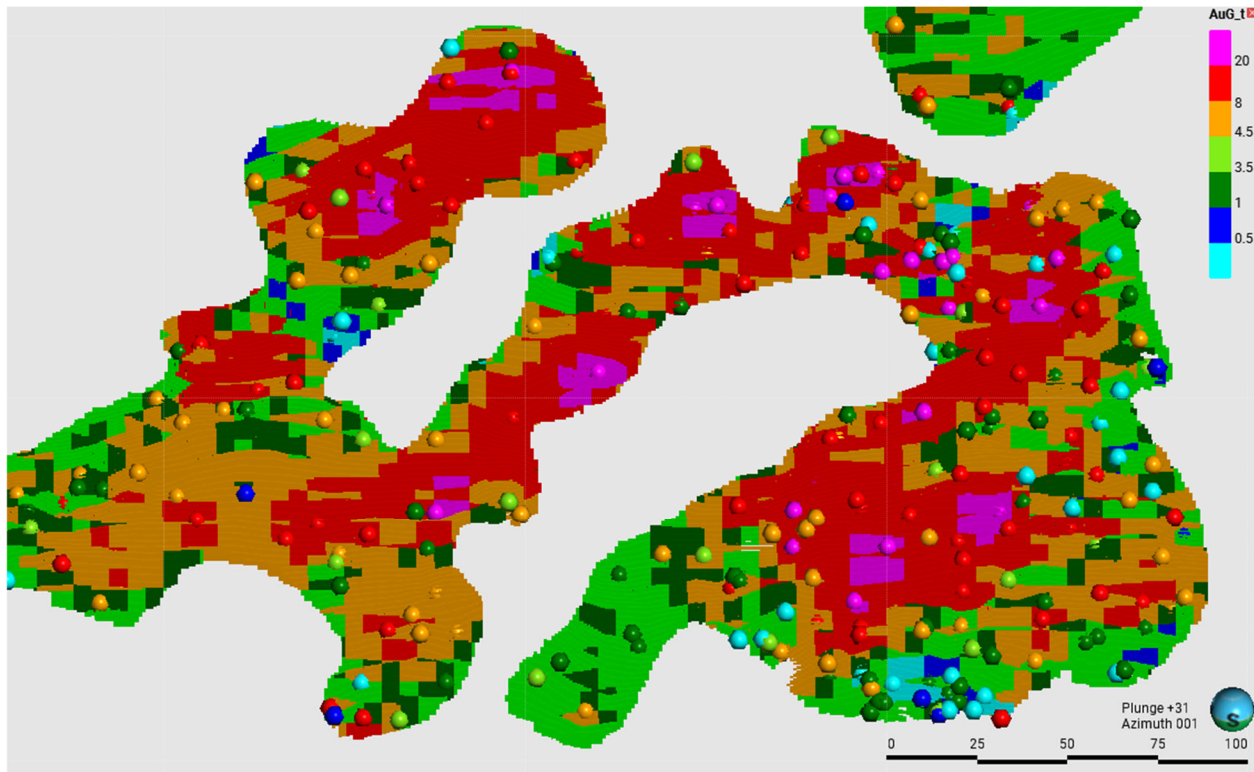

Figure 14-4: C4-30 Splay Zone Showing Block Model Grades and Composites (Eldorado 2024)

#### 14.1.9.2 Model Checks for Bias

The block model estimates were checked for global bias by comparing the average metal grades from the model with means from NN estimates. The NN estimator declusters the data and produces a theoretically unbiased estimate of the average value and is a good basis for checking the performance of different estimation methods. Results, summarized in Table 14-6, show a few main splays that are underestimated (C1, C2, C3, C5, and C8B). Most of them are already or currently being mined. A few splays also show some underestimating where drilling is sparse. Lastly, in total the study shows no bias (5%).

Table 14-6: Global Model Mean Gold (g/t) Values by Mineralized Domain, Triangle Deposit

Domain	Mean Estimate	Mean NN	Difference %
C1	4.47	4.83	-7.42
C2	7.07	7.50	-5.81
C3	9.77	11.78	-17.05
C4	8.89	9.19	-3.17
C4-01	4.18	5.03	-16.90
C5	7.47	7.94	-5.92
C6	4.62	4.76	-3.10
C7	6.85	7.08	-3.30
C8	5.01	5.24	-4.32
C8B	6.70	7.60	-11.85
C9	5.54	5.53	0.14
C9B	6.18	6.30	-1.89
C10	8.28	8.47	-2.16
C10B	4.75	4.75	-0.04
C10S	6.27	6.44	-2.62
C11	5.61	5.75	-2.44
C1 Splays	5.60	5.81	-3.66
C2 Splays	6.67	6.85	-2.60
C3 Splays	5.28	5.34	-1.03
C4 Splays	5.84	6.06	-3.51
C5 Splays	4.73	4.57	3.65
C6 Splays	5.99	6.67	-10.20
C7 Splays	3.76	3.53	6.45
C8 Splays	6.91	7.89	-12.47
C9 Splays	10.66	11.35	-6.08
C10 Splays	6.75	6.99	-3.45
<b>TOTAL</b>	<b>6.30</b>	<b>6.66</b>	<b>-5.42</b>

Triangle models were also checked for local trends in the grade estimates by grade slice or swath checks. This was done by plotting the mean values from the NN estimate versus the estimated results for easting, northing, and elevation. The estimates should be smoother than the NN, thus the NN should fluctuate around the estimates on the plots. The observed trends, displayed in Figure 14-5 and Figure 14-6 behave as predicted and show no significant deviation of gold in the estimates.

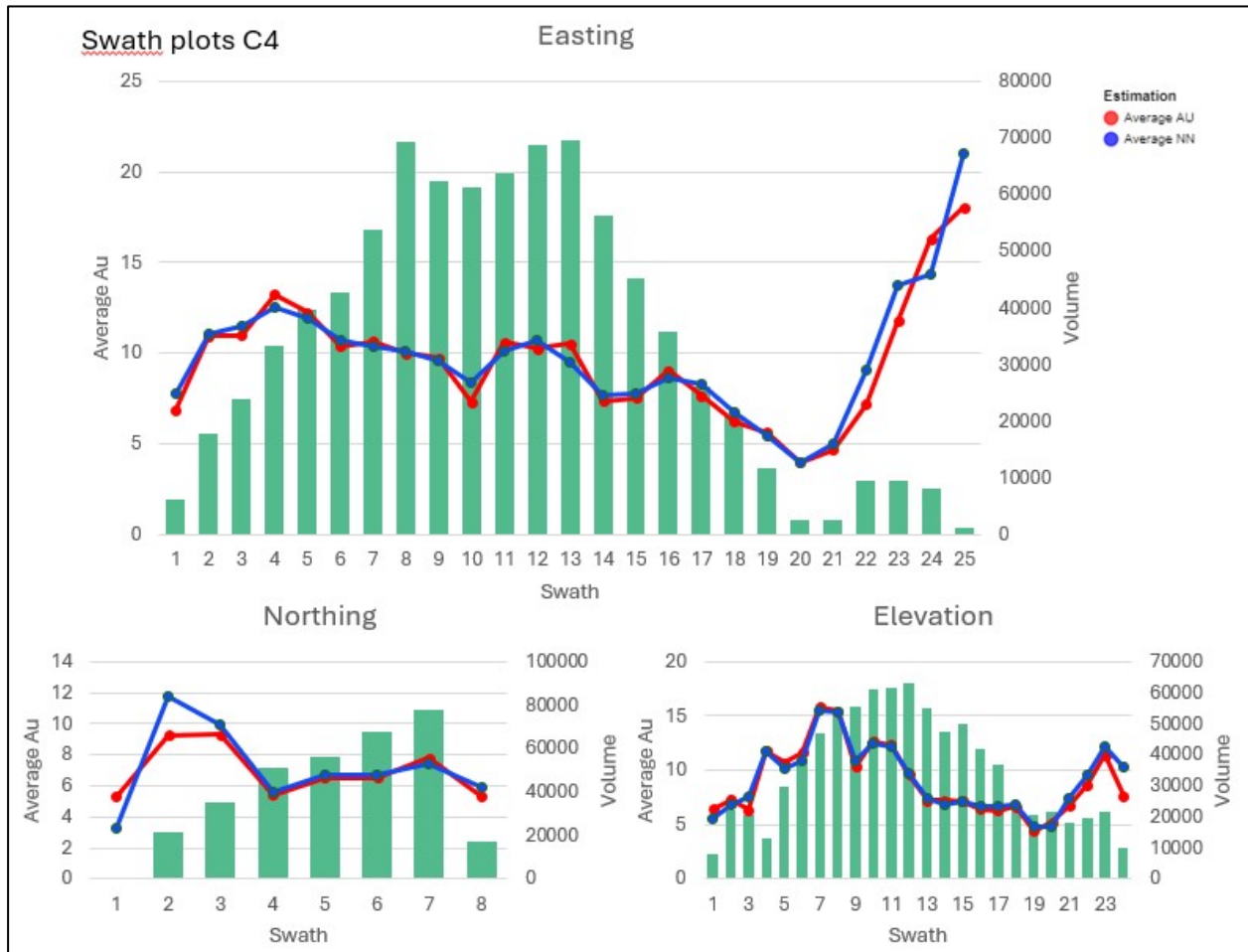
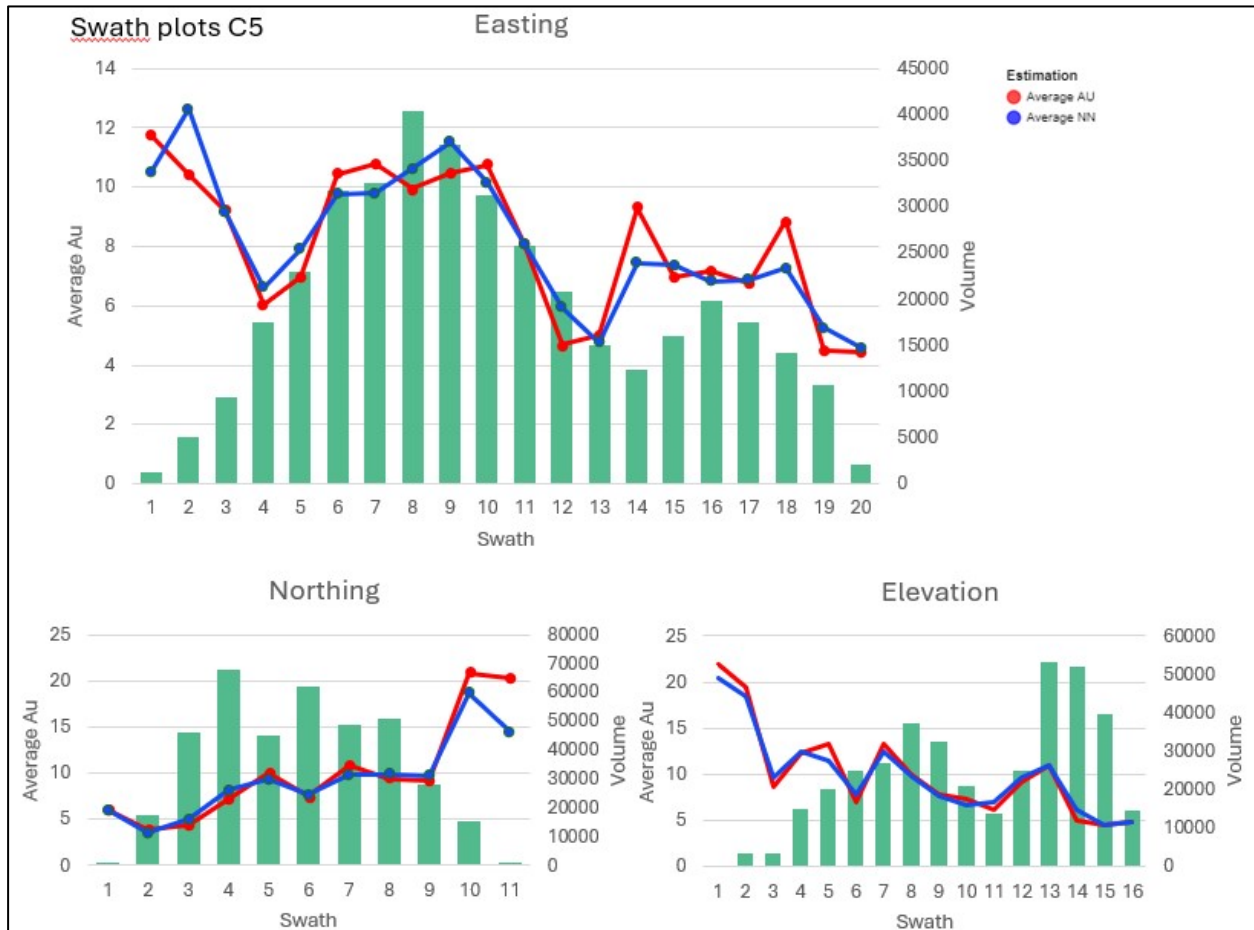

Figure 14-5: Model Trend Plots Showing 5 m Binned Averages Along Elevations & Eastings for Kriged (Au) & Nearest Neighbour Gold Grade Estimates, C4 Main Zone, Triangle Deposit (Eldorado 2024)



**Figure 14-6: Model Trend Plots Showing 5 m Binned Averages Along Elevations and Eastings for Kriged and Nearest Neighbour Gold Grade Estimates, C5 Main Zone, Triangle Deposit (Eldorado 2024)**

#### 14.1.10 Mineral Resource Classification

The Mineral Resource of the Triangle deposit was classified using logic consistent with the CIM Definition Standards for Mineral Resources and Mineral Reserves referred to in National Instrument 43-101 – *Standards of Disclosure of Mineral Projects (NI 43-101)*. The mineralization of the project satisfies sufficient criteria to be classified into Measured, Indicated, and Inferred Mineral Resource categories.

Inspection of the Triangle model and drillhole data on plans and cross-sections, combined with spatial statistical analysis contributed to the setup of protocols to help guide the assignment of blocks into Measured, Indicated or Inferred Mineral Resource categories. Reasonable grade and geologic continuity are demonstrated over most of the C2, C3-100, C4, C4-30, C5, and C7 zones in the Triangle deposit. Blocks that are within an area where drillhole spacing is below 15 m were classified as Measured Mineral Resources. Indicated resource blocks were classified in areas where the average distance between drillholes is below 40 m. All remaining model blocks containing a gold grade estimate were assigned as Inferred Mineral Resources.

### 14.1.11 Mineral Resource Summary

The Mineral Resources for the Triangle deposit, as of September 30, 2024, are shown in Table 14-7 where splays are grouped with the main zones. The Mineral Resources are reported within the constraining mineralized domain volumes that were created to control resource reporting at a 3.0 g/t Au cut-off grade.

**Table 14-7: Triangle Mineral Resources, as of September 30, 2024**

Deposit Name	Categories	Tonnes (x 1,000)	Grade Au (g/t)	Contained Au (oz x 1,000)
Upper Triangle	Measured	2,268	6.53	476
	Indicated	2,977	6.47	619
	<b>Measured + Indicated</b>	<b>5,245</b>	<b>6.49</b>	<b>1,095</b>
	<b>Inferred</b>	<b>1,166</b>	<b>6.46</b>	<b>242</b>
Lower Triangle	Measured	0	0	0
	Indicated	459	7.59	112
	<b>Measured + Indicated</b>	<b>459</b>	<b>7.59</b>	<b>112</b>
	<b>Inferred</b>	<b>6,342</b>	<b>6.52</b>	<b>1,332</b>

There are no foreseen legal, political, environmental, environmental, permitting, title, taxation, socio-economic, marketing, political, or other risks or relevant factors that could materially affect the Mineral Resource Estimates.

**Table 14-8: Triangle Mineral Resources, as of September 30, 2024**

	Shear Zones (Main + Splays)	Categories	Tonnes (x 1,000)	Grade Au (g/t)	Contained Au (oz x 1,000)
	Surface Stockpile	Measured	33	5.66	6
UPPER TRIANGLE	C1	Measured	157	5.15	26
		Indicated	659	4.86	103
		Inferred	18	3.46	2
	C2	Measured	300	6.32	61
		Indicated	257	6.54	54
		Inferred	23	6.76	5
	C3	Indicated	286	5.33	49
		Inferred	224	5.69	41
	C4	Measured	90	6.22	18
		Indicated	1,328	6.63	283
		Inferred	1,158	6.58	245
	C5	Measured	361	7.32	85
		Indicated	164	9.67	51
Inferred		679	8.06	176	
Upper Triangle Total	Measured	2,268	6.53	476	
	Indicated	2,977	6.47	619	
	M&I	5,245	6.49	1,095	

	Shear Zones (Main + Splays)	Categories	Tonnes (x 1,000)	Grade Au (g/t)	Contained Au (oz x 1,000)
LOWER TRIANGLE	C6	Inferred	1,166	6.49	242
		Indicated	219	6.96	49
		Inferred	703	5.53	125
	C7	Indicated	240	8.16	63
		Inferred	435	7.01	96
	C8	Inferred	1,635	5.25	276
	C9	Inferred	2,200	7.42	525
	C10	Inferred	1,224	7.19	283
C11	Inferred	145	5.36	25	
Lower Triangle Total	Measured	0	0.00	0	
	Indicated	459	7.59	112	
	M&I	459	7.59	112	
	Inferred	6,342	6.53	1,332	
Total	Total Triangle Resources	Measured	2,268	6.53	476
		Indicated	3,436	6.62	731
		<b>Measured + Indicated</b>	<b>5,704</b>	<b>6.58</b>	<b>1,207</b>
		<b>Inferred</b>	<b>7,508</b>	<b>6.52</b>	<b>1,574</b>

## 14.2 Parallel Deposit

### 14.2.1 Introduction

The Mineral Resource estimate for the Parallel deposit used data from surface diamond drillholes. The Mineral Resource estimates were made from 3D block models created by utilizing commercial geological modelling and mine planning software. The block model cell size is 5 m east by 5 m north by 5 m high. The block model was not rotated.

### 14.2.2 Mineralization Domains

The interpretation of mineralization solids is underpinned by a geological review of structure, alteration and veining carried out by site geologists. Geological concepts at Parallel were reviewed to reflect current understanding of the role of steep structures gained at Triangle. In the Parallel case, the most significant mineralization is found in moderately dipping hybrid shear / extensional zones in the footwall of a non-mineralized higher order steep shear zone. Minor mineralization associated with horizontal extensional veining is present in the hanging wall of the same shear zone.

Site geologists capture the geological elements defining mineralization in a separate composite field which defines and labels each mineralized zone. The hard boundary solids were created using the vein modeling module in Leapfrog Geo from an interval selection largely based on the composite field. The selection was locally changed to ensure spatial coherence and continuity in 3D.

There were two sets of solids produced: The first set consisted of mineralization solids, which connect all intervals defined by the composite field, irrespective of grade; these solids track the geological elements supporting the mineralization, and second set consisted of resource solids, which are based on the

mineralization solids but that are restricted / clipped by removing material below a cut-off of ~2.5 g/t Au. At Parallel, 11 main extension / shear zones were modelled (Figure 14-7 and Figure 14-8).

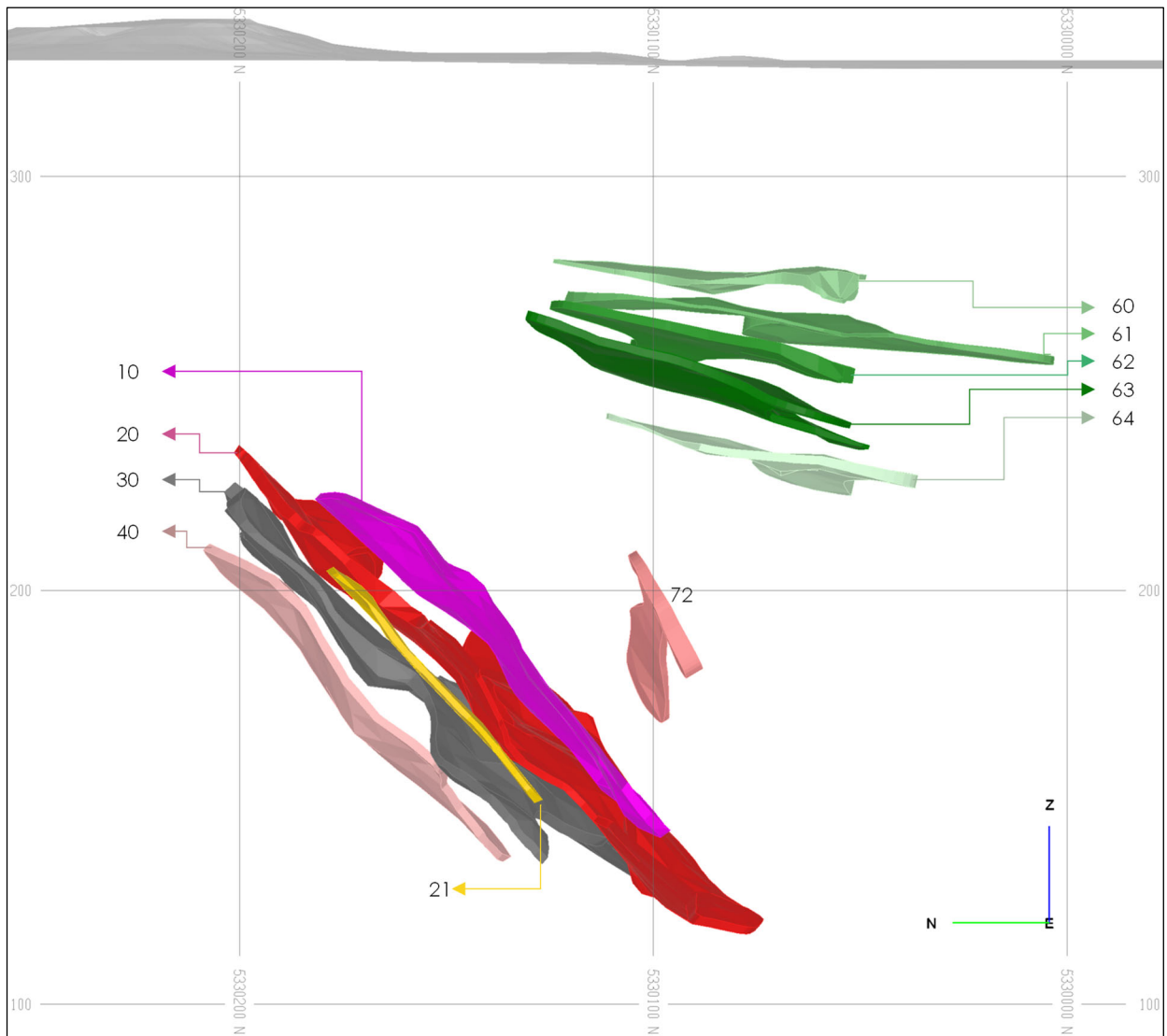

**Figure 14-7: 3D Sectional View Looking East of the Modeled Resource Solids Extension / Shear Zones at Parallel (Eldorado 2024)**

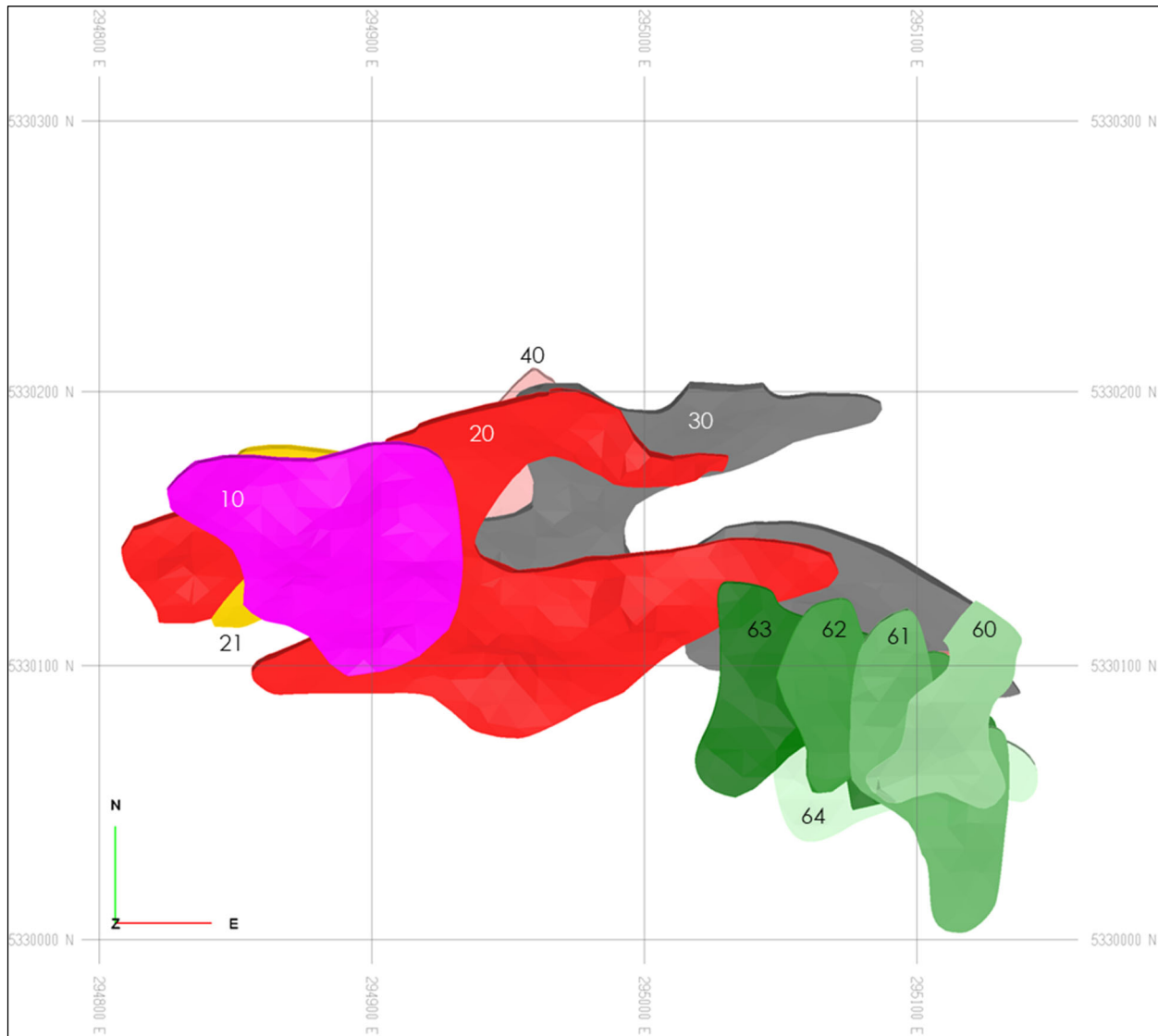

**Figure 14-8: 3D Plan View of the Modelled Resource Solids Extension / Shear Zones at Parallel (Eldorado 2024)**

### 14.2.3 Data Analysis

The mineralized domains were reviewed to determine appropriate estimation or grade interpolation parameters. Several different procedures were applied to the data. Descriptive statistics, histograms and cumulative probability plots and box plots have been completed for composite data. The results were used to guide the construction of the block model and the development of estimation plans including treatment of extreme grades. These analyses were conducted on 1 m composites of the assay data. The statistical properties from this analysis are summarized for both uncapped and capped data in Table 14-9 and Table 14-10 for the Parallel deposit.

**Table 14-9: Parallel Deposit Composite Statistics for 1 m Uncapped Composite Au (g/t) Data**

Domain	Number	Min	Max	Mean	Q25	Q50	Q75	SD	CV
10	43	0.01	49.45	9.56	0.78	7.75	15.55	10.46	1.09
20	94	0.01	152.24	11.69	1.01	3.74	8.99	24.10	2.06
21	19	0.03	11.24	2.98	0.74	1.44	4.28	3.38	1.13
30	140	0.05	148.09	12.02	1.45	5.85	11.96	20.54	1.71
40	15	0.05	103.97	14.95	0.25	3.24	20.13	27.84	1.86
60	29	0.06	11.50	3.58	0.68	1.83	5.79	3.72	1.04
61	17	0.02	68.83	16.10	1.56	7.09	20.57	22.31	1.39
62	19	0.32	108.73	13.90	2.62	7.96	13.97	24.22	1.74
63	28	0.03	226.26	16.11	0.77	3.68	12.30	42.34	2.63
64	29	0.01	41.47	6.68	1.40	3.52	11.36	8.76	1.31
72	17	0.7	22.52	8.48	2.19	7.45	14.95	6.86	0.81

Note: Min = minimum value; Max = maximum value; Mean = average value; Q25 = value at the 25th frequency percentile of the data; Q50 = value at the 50th frequency percentile of the data, i.e., the median; Q75 = value at the 75th frequency percentile of the data; SD = standard deviation of the data; CV = Coefficient of Variation of the data and equals SD / Mean.

**Table 14-10: Parallel Deposit Composite Statistics for 1 m Capped Composite Au (g/t) Data**

Domain	Number	Min	Max	Mean	Q25	Q50	Q75	SD	CV
10	43	0.01	49.45	9.56	0.78	7.75	15.55	10.46	1.09
20	94	0.01	56.59	8.68	1.01	3.74	8.99	12.76	1.47
21	19	0.03	11.24	2.98	0.74	1.44	4.28	3.38	1.13
30	140	0.05	60.00	10.05	1.44	5.85	11.96	13.02	1.30
40	15	0.05	60.00	11.43	0.25	3.24	14.02	18.34	1.61
60	29	0.06	11.50	3.58	0.68	1.83	5.79	3.72	1.04
61	17	0.02	58.66	13.46	1.56	7.09	20.57	17.22	1.28
62	19	0.32	33.28	9.09	2.62	7.96	11.15	8.17	0.90
63	28	0.03	60.00	10.17	0.77	3.68	12.30	13.85	1.36
64	29	0.01	24.74	6.10	1.40	3.52	11.36	6.70	1.10
72	17	0.7	22.52	8.48	2.19	7.45	14.95	6.86	0.81

Note: Min = minimum value; Max = maximum value; Mean = average value; Q25 = value at the 25th frequency percentile of the data; Q50 = value at the 50th frequency percentile of the data, i.e., the median; Q75 = value at the 75th frequency percentile of the data; SD = standard deviation of the data; CV = Coefficient of Variation of the data and equals SD / Mean.

#### 14.2.4 Evaluation of Extreme Grades

Outlier sample grades can cause overestimation in the resource model if left untreated. Extreme grades for gold were examined by means of cumulative probability plots and histograms. Local areas show extreme grades. These were mitigated by gold capping to 60 g/t prior to compositing. The number of capped Parallel samples was 20.

## 14.2.5 Bulk Density

A constant bulk density of 2.8 t/m<sup>3</sup> was used for the Parallel deposit. This is based on measurements from earlier work and extensive experience in the Val d'Or camp with similar deposits.

## 14.2.6 Model Set-up

The model was set-up using MineSight software. The block size for the Parallel model was selected based on selectivity associated with underground mining and limits shown as in the Table 14-11.

The capping limits were applied to the assay data prior to compositing. The assays were composited into 1 m fixed length down-hole composites. Intervals of less than 0.5 m lengths were merged into the preceding composite. A second set of composites, composited over the full thickness of the zone if less than 5 m or limited to 5 m fixed intervals in wider areas, was created for model validation purposes. The compositing honoured the estimation domain by breaking the composites on the domain code values. The compositing process was reviewed and found to have performed as expected.

Various coding was done on the block model in preparation for grade interpolation. The block model was coded according to domains for usage of different search ellipsoids.

**Table 14-11: Block Model Limits and Block Size in Parallel Deposit**

	Minimum (m)	Maximum (m)	Block Size (m)	Number of Blocks
East	294,400	295,550	5	230
North	5,329,700	5,330,450	5	150
Elevation	-400	350	5	150

## 14.2.7 Estimation

Grade estimation for gold was interpolated using inverse distance to the power of 2 for all the zones except 10, 20, and 62 where distance to the power of 3 was applied. NN grades were also interpolated for validation purposes but were interpolated using the longer length composite data set. Blocks and composites were matched on mineralized zone or domain.

For the interpolation, the maximum number of samples required for the interpolation ranged from 8 to 18. The minimum number of samples required from a single hole ranged from 3 to 7. The number of samples, number of drillholes, and the average distance of the samples used in estimation were stored during the interpolation for use in the definition of Mineral Resource classification. A spherical search ellipse with 55 m radius was used during ID interpolation.

An outlier restriction was used to control the effects of high-grade composites in areas of less dense drilling or low-grade intersection areas. The outlier value was 15 to 40 g/t Au for Zones 21, 30, 40, 62, 63, and 72. The maximum distance imposed on these outliers ranged from 10 to 35 m.

## 14.2.8 Validation

### 14.2.8.1.1 Visual Inspection

Eldorado completed a detailed visual validation of the Parallel resource models. They were checked for proper coding of drillhole intervals and block model cells, in both cross-section and plan views. Coding was found to be accurate. Grade interpolation was examined relative to drill hole composite values by inspecting cross-sections and plans. The checks showed good agreement between drill hole composite values and model cell values. The hard boundaries appear to have constrained grades to their respective estimation

domains. The addition of the outlier restriction values succeeded in minimizing grade smearing in regions of sparse data. Examples of representative sections containing block model grades, drill hole composite values, and domain outlines are shown in Figure 14-9 and Figure 14-10.

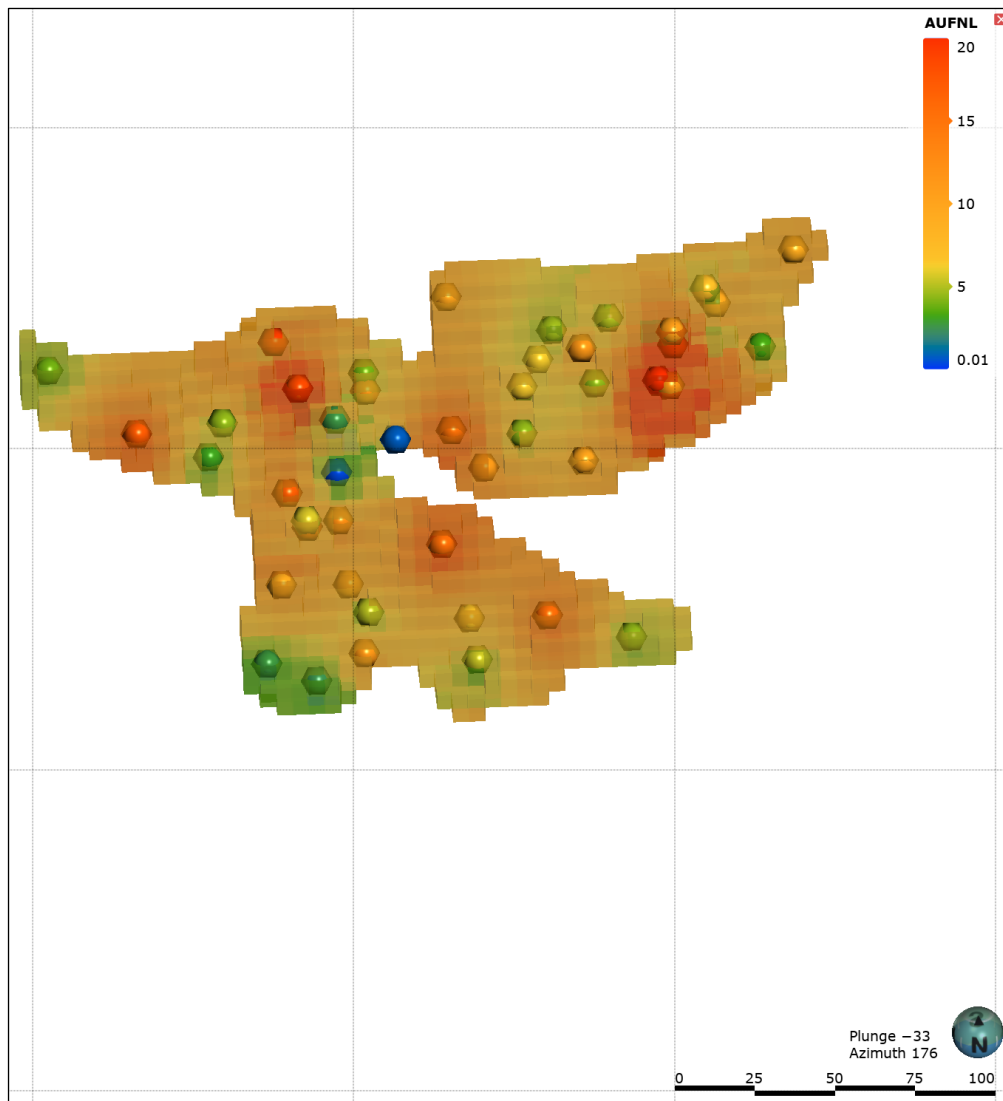

Figure 14-9: Zone 30 Showing Gold Composite Data and Gold Block Model (Eldorado 2024)

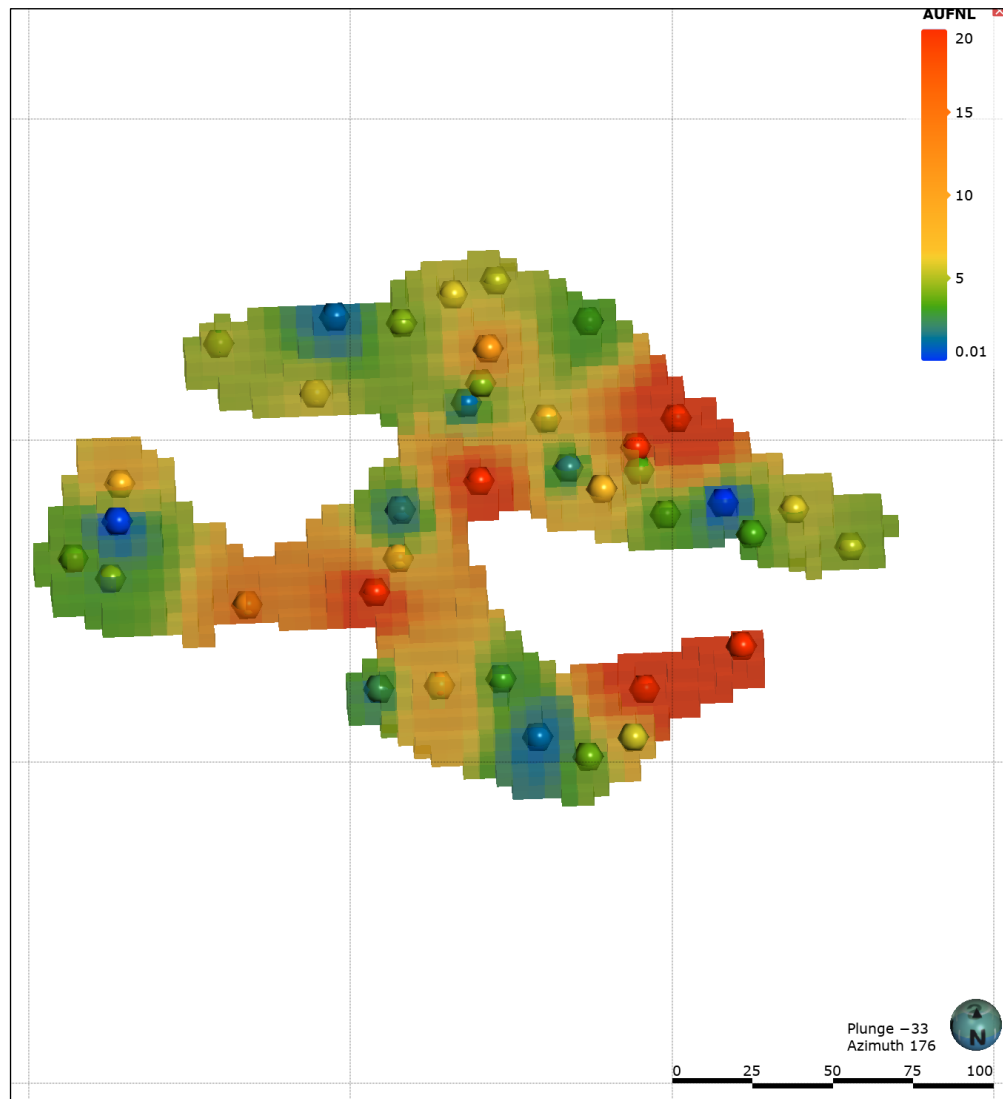

Figure 14-10: Zone 20 Showing Gold Composite Data and Gold Block Model (Eldorado 2024)

#### 14.2.8.2 Model Checks for Bias

The block model estimates were checked for global bias by comparing the average metal grades (with no cut-off) from the model with means from NN estimates. The NN estimator declusters the data and produces a theoretically unbiased estimate of the average value when no cut-off grade is imposed and is a good basis for checking the performance of different estimation methods. Results, summarized in Table 14-12, show no global bias in the estimates.

**Table 14-12: Global by Mineralized Domain, Parallel Deposit Model Mean Gold Values**

Domain	ID Estimate	NN Estimate	Difference (%)
10	10.22	10.72	4.71%
20	8.18	8.35	2.07%
21	2.95	2.99	1.37%
30	9.82	9.94	1.24%
40	11.28	11.77	4.19%
60	3.39	3.28	-3.32%
61	12.67	13.25	4.33%
62	9.04	9.02	-0.20%
63	9.70	10.15	4.42%
64	6.09	6.29	3.05%
72	7.68	7.64	-0.55%

Parallel models were also checked for local trends in the grade estimates by grade slice or swath checks. This was done by plotting the mean values from the NN estimate versus the estimated results for benches and eastings (both in 5 m swaths). The observed trends, displayed in Figure 14-11 behave as predicted and show no significant trends of gold in the estimates.

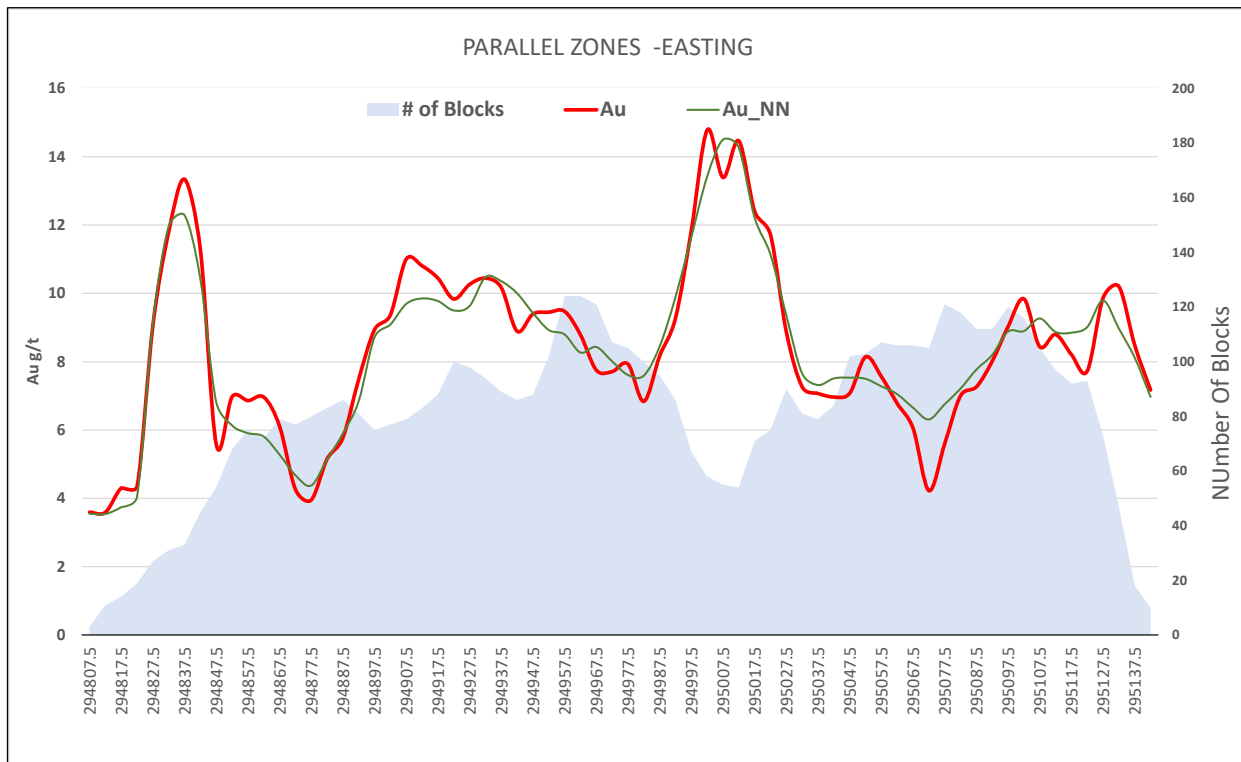
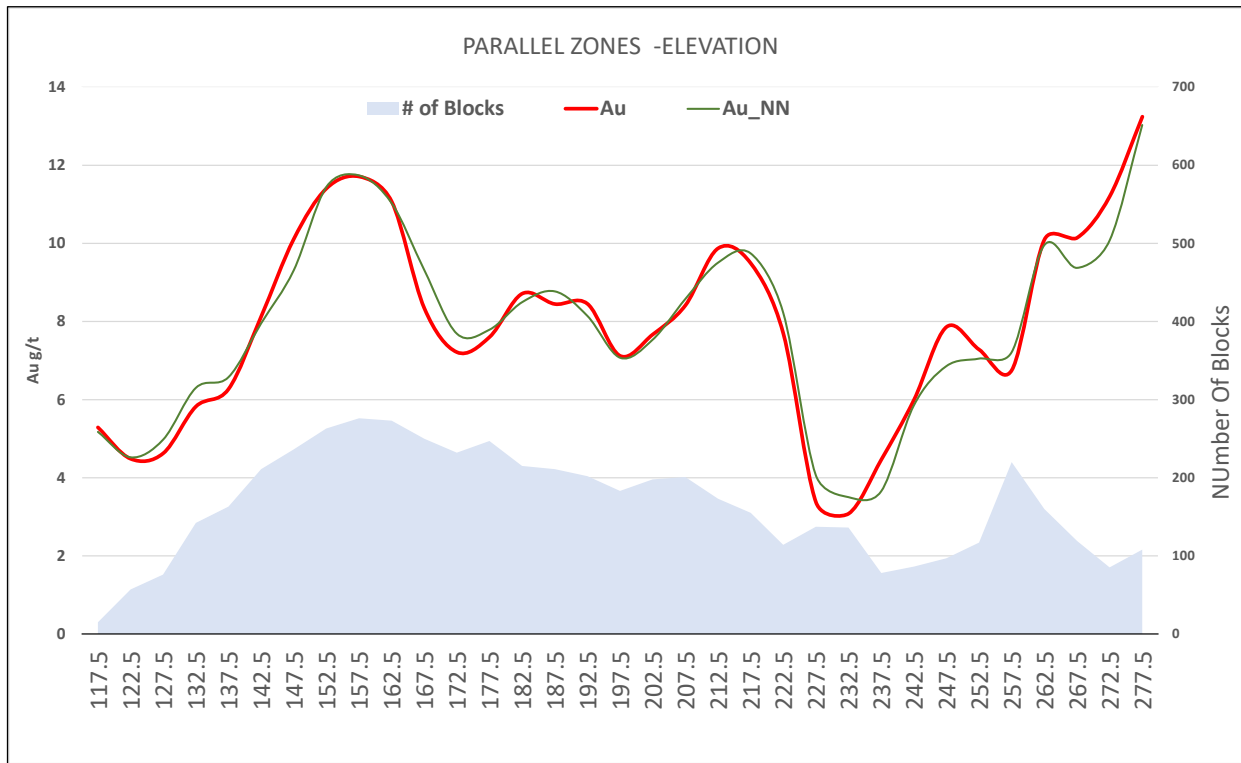

**Figure 14-11: Model Trend Plots Showing 5 M Binned Averages Along Elevations and Eastings for Au (IDW) and Nearest Neighbour Gold Grade Estimates, Parallel Deposit (Eldorado 2024)**

## 14.2.9 Mineral Resource Classification

The Mineral Resources of the Parallel deposit were classified using logic consistent with the CIM Definition Standards for Mineral Resources and Mineral Reserves referred to in NI 43-101. The mineralization of the project satisfies sufficient criteria to be classified into indicated and inferred mineral resource categories.

Due to its similarity to the Triangle deposit, the same classification approach is used in the Parallel deposit, where the average distance of the samples to a block center interpolated by samples from at least two drill holes, up to 30 m were classified as indicated mineral resources. All remaining model blocks containing a gold grade estimate were assigned as inferred mineral resources.

### 14.2.10 Mineral Resource Summary

The Mineral Resources for the Parallel deposit, as of September 30, 2024, are shown in Table 14-13. The Mineral Resources are reported within the constraining domain volumes that were created to control resource reporting and at a 3.0 g/t gold cut-off grade.

**Table 14-13: Parallel Mineral Resources, as of September 30, 2024**

Shear / Extensional Zone	Categories	Tonnes (x 1,000)	Grade Au (g/t)	Contained Au (oz x 1,000)
10	Indicated	40	10.98	14.1
	Inferred	8	11.38	2.8
20	Indicated	72	9.27	21.5
	Inferred	42	7.55	10.1
21	Indicated	4	4.48	0.6
	Inferred	4	3.76	0.4
30	Indicated	105	10.06	34.0
	Inferred	36	9.11	10.5
40	Indicated	17	11.28	6.3
60	Inferred	10	4.91	1.6
61	Inferred	13	12.68	5.5
62	Inferred	17	9.79	5.2
63	Inferred	23	9.70	7.3
64	Inferred	21	7.05	4.8
72	Inferred	9	7.69	2.2
	<b>Total Indicated</b>	<b>221</b>	<b>9.87</b>	<b>70.2</b>
	<b>Total Inferred</b>	<b>200</b>	<b>8.83</b>	<b>56.7</b>

There are no foreseen legal, political, environmental, environmental, permitting, title, taxation, socio-economic, marketing, political, or other risks or relevant factors that could materially affect the mineral resource estimates.

## 14.3 Plug No. 4

### 14.3.1 Introduction

The interpretation of mineralization solids is underpinned by a geological review of structure, alteration and veining carried out by site geologists. Geological concepts at Plug No. 4 (Figure 14-12) were reviewed to reflect current understanding of the role of steep structures gained at Triangle. At Plug No. 4, there is a distinct set of stacked steep shear zones similar to Triangle in orientation but restricted to the core of the Plug No. 4 intrusive. Particular to Plug No. 4 is the occurrence of sub-horizontal vein arrays associated with these steep mineralized shears. The vein arrays are stronger in the FW of main steep zones or between steep zones occurring close together.

### 14.3.2 Mineralization Domains

Site geologists capture the geological elements defining mineralization in a separate composite field which defines and labels each steep mineralized zone. The hard boundary solids were created using the vein modelling module in Leapfrog Geo from an interval selection largely based on the composite field. The selection was locally changed to ensure spatial coherence and continuity in 3D. The sub-horizontal set of vein arrays was modelled based on gold grade and vein density and taking into consideration a structural concept of flat extensional zones connecting to steep shears.

Two sets of solids were produced for the steep zones: 1) mineralization solids, which connect all intervals defined by the composite field, irrespective of grade. These solids track the geological elements supporting the mineralization. 2) Resource solids, which are based on the mineralization solids but restrict/clip zones laterally by removing material below cut-off (~2.5 g/t Au). The flat zones are captured in a single set of solids representing spatially coherent zones above 0.5 g/t Au.

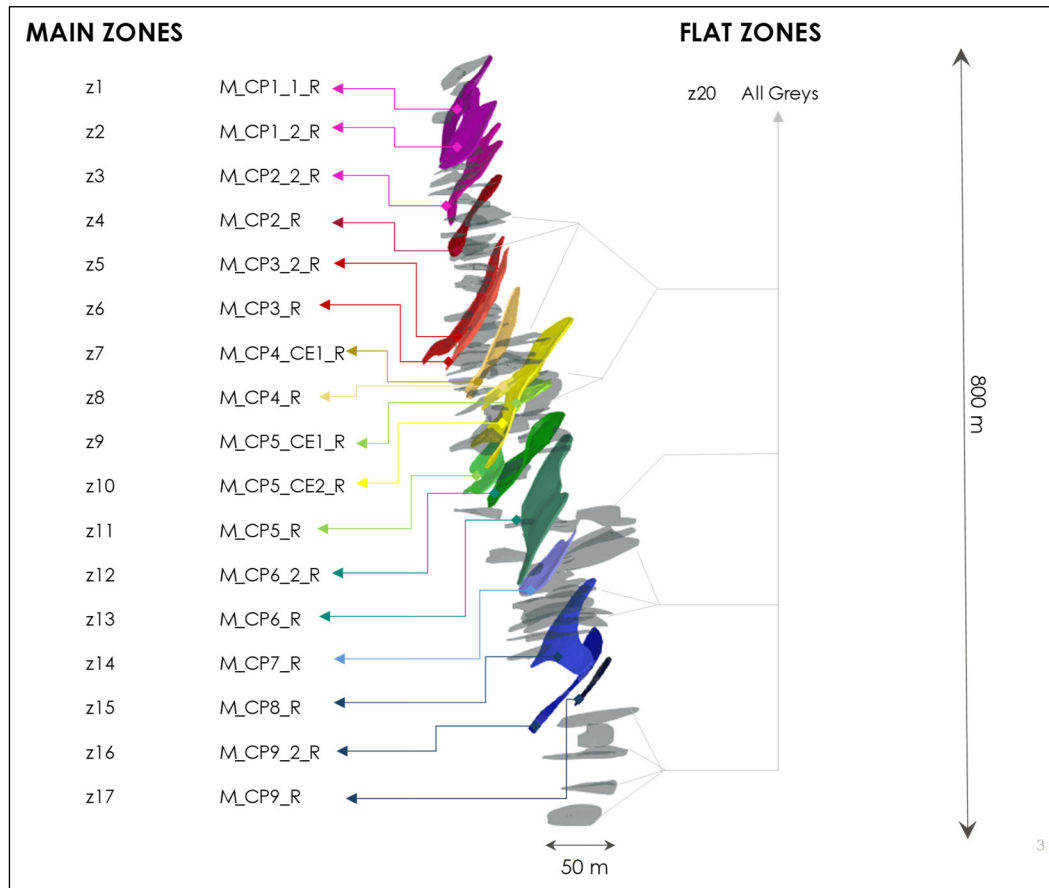

Figure 14-12: 3D Sectional View of the Modelled Resource Solids at Plug No. 4 (Eldorado 2024)

### 14.3.3 Data Analysis

A summary of the assay statistics for the identified zones and the Flats composite area follows in Table 14-14.

Table 14-14: Plug No. 4 Assay Statistics by Zone (Uncapped Au (g/t) Data)

Name	Count	Mean	SD	CV	Variance	Min	Q25	Q50	Q75
Zone 1	147	4.77	9.54	2.00	91.04	0.02	0.39	1.80	5.10
Zone 2	75	5.03	11.00	2.19	120.93	0.00	0.18	1.36	4.86
Zone 3	72	3.31	6.81	2.06	46.31	0.01	0.12	0.99	3.07
Zone 4	118	7.86	22.26	2.83	495.72	0.01	1.00	2.54	7.42
Zone 5	167	5.92	14.50	2.45	210.30	0.01	0.46	1.61	4.12
Zone 6	137	8.36	20.86	2.50	434.97	0.01	0.42	2.44	7.50
Zone 7	38	9.15	21.55	2.35	464.37	0.01	0.54	1.97	6.33
Zone 8	87	16.02	76.38	4.77	5834.20	0.01	0.52	1.86	4.84
Zone 9	45	6.67	16.31	2.45	266.15	0.01	0.05	0.92	4.08
Zone 10	29	3.40	4.06	1.19	16.48	0.02	1.18	2.18	4.60
Zone 11	112	3.75	7.90	2.11	62.43	0.01	0.12	1.23	4.32
Zone 12	64	1.84	2.87	1.57	8.26	0.02	0.17	0.85	1.95

Name	Count	Mean	SD	CV	Variance	Min	Q25	Q50	Q75
Zone 13	93	7.35	32.98	4.49	1087.98	0.00	0.30	1.52	4.15
Zone 14	44	6.71	7.69	1.15	59.18	0.04	0.41	4.05	11.49
Zone 15	42	9.87	66.08	6.69	4366.18	0.01	0.25	1.47	3.41
Zone 16	27	8.-7	15,40	1.91	237.24	0.01	1.81	3.84	6.61
Zone 17	50	5.70	6.42	1.13	41.21	0.02	1.20	4.22	8.23
Flats	2644	3.36	16.07	4.78	258.36	0.00	0.05	0.93	2.87

#### 14.3.4 Evaluation of Extreme Grades

A capping strategy was used based on a capping grade of 60 g/t. A total of 47 samples were capped across the Plug No. 4 zones. After capping was applied, samples were composited in 1 m composites by zone. Intervals of less than 0.25 m were added to the previous interval. To remove a clustering effect, 5 m composites were also created and used for NN estimation. A summary of composited statistics follows in Table 14-15.

**Table 14-15: Plug No. 4 Composite Statistics by Zone (Capped Au (g/t))**

Name	Data	Mean	SD	CV	Variance	Min	Q25	Q50	Q75
Zone 1	108	4.77	7.83	1.64	61.28	0.03	0.85	2.34	5.36
Zone 2	65	5.02	9.63	1.92	92.76	0.00	0.32	1.54	5.44
Zone 3	53	3.31	5.82	1.76	33.87	0.01	0.63	1.46	3.54
Zone 4	86	7.86	14.91	1.90	222.43	0.01	1.38	3.14	7.25
Zone 5	126	5.93	11.31	1.91	127.86	0.01	0.72	1.89	5.85
Zone 6	113	8.36	17.61	2.11	310.17	0.01	0.76	2.85	7.58
Zone 7	36	8.97	16.19	1.81	262.23	0,01	0.89	2.71	12.14
Zone 8	72	16.26	75.73	4.66	5735.08	0,02	1.05	2.21	5.50
Zone 9	32	6.81	10.69	1.57	114.18	0.01	0.57	1.62	7.76
Zone 10	25	3.40	2.99	0.88	8.97	0.90	1.27	2.65	4.56
Zone 11	86	3.75	6.84	1.82	46.79	0.01	0.41	1.76	4.43
Zone 12	58	1.83	2.49	1.36	6.21	0.02	0.20	0.94	2.30
Zone 13	75	7.35	22.00	2.99	484.16	0.00	0.63	2.43	4.56
Zone 14	41	6.72	6.10	0.91	37.20	0.08	1.68	4.07	11.55
Zone 15	38	11.83	37.55	3.17	1410.18	0.01	0.36	2.02	3.90
Zone 16	24	7.71	12.25	1.59	149.95	0.01	1.82	4.11	9.88
Zone 17	42	5.70	6.15	1.08	37.80	0.02	1.25	4.52	7.85
Flats	2139	3.36	10.55	3.14	111.32	0.00	0.25	1.15	3.03

#### 14.3.5 Bulk Density

A bulk density of 2.8 g/cm<sup>3</sup> was used for all of the blocks in Plug No. 4.

#### 14.3.6 Estimation

The Inverse Distance method was used for each of 17 Main Zone solids, which were treated as a hard boundary. Mineralization shapes called Flats were based on constituting 66 individual solids. Ideally, each flat

solid would have been treated as a hard boundary but this would represent unnecessarily complex modeling. To achieve a similar result, an arrow search ellipse (60x60x10m) that was oriented as flats and used so that interpolation with samples from the other flat mineralization was minimized.

### 14.3.7 Mineral Resource Classification

The Mineral Resources of the Plug No. 4 zone were classified using logic consistent with the CIM Definition Standards for Mineral Resources and Mineral Reserves referred to in NI 43-101. The Mineral Resources for Plug No. 4, as of September 30, 2024, are shown in Table 14-16. The mineral resources are reported within the constraining volumes that were created to control resource reporting at a 3.5 g/t gold cut-off grade.

**Table 14-16: Plug No. 4 Mineral Resources, as of September 30, 2024**

Deposit Name	Categories	Tonnes (x 1,000)	Grade Au (g/t)	Contained Au (oz x 1,000)
Plug No. 4	Indicated	709	6.39	146
	Inferred	481	6.67	103

## 14.4 Ormaque Deposit

### 14.4.1 Introduction

The Mineral Resource estimate for the Ormaque deposit used data from surface diamond drillholes. The resource estimates were made from 3D block models created by utilizing commercial geological modelling and mine planning software. The block model cell size is 5 m east by 5 m north by 5 m high and is then sub-blocked to 1 m east, 1 m north and a variable height between 0.1 to 1 m.

### 14.4.2 Mineralization Domains

Gold mineralization at Ormaque is hosted mostly by arrays of thin, gently-dipping, extensional quartz-tourmaline veins that occur within with the C-porphyry intrusion. Interpretation of the geologic and structural framework of the Ormaque vein system involved collection of oriented drill core measurements and modelling using Seequent's Leapfrog Geo software. Core orientation followed rigorous QA/QC monitoring during logging and data collection. Planar structural data were grouped and filtered by structural type and style. Orientation data were statistically analyzed to determine representative vein and shear zone orientations and to inform the construction of structural form interpolant surfaces, which allowed for 3D visualization of structural trends. Intervals containing extensional quartz-tourmaline-carbonate veins were modelled by compositing Au-bearing intercepts over a minimum width of 0.5 m (smallest sample length). Composites were allowed to incorporate multiple thin veins and a maximum of 4.5 m of thickness. Guided by the trends established by the structural form interpolants, composites were grouped and then modelled into 3D volumes using the implicit geological model in Leapfrog Geo. From this model, refining was done locally by the project geologist. This compositing approach, in tandem with detailed geologic observations, oriented core measurements and structural form interpolant visualization, allowed for the accurate and consistent modeling of vein geometry and established the geologic framework on which this resource estimate was made.

A total of 54 extensional veins/vein arrays are included as individual mineralization domains in the mineral resource estimation; The included domains were assessed individually for their reasonable prospects for eventual economic extraction (RPEEE); a minimum mining height of 3 m was considered at a diluted gold grade of 3.5 g/t. The mineralized domains were edited to remove those portions that did not meet the diluted grade and mining height requirements for RPEEE. Figure 14-13 shows the extensional vein domains in a north-facing vertical view.

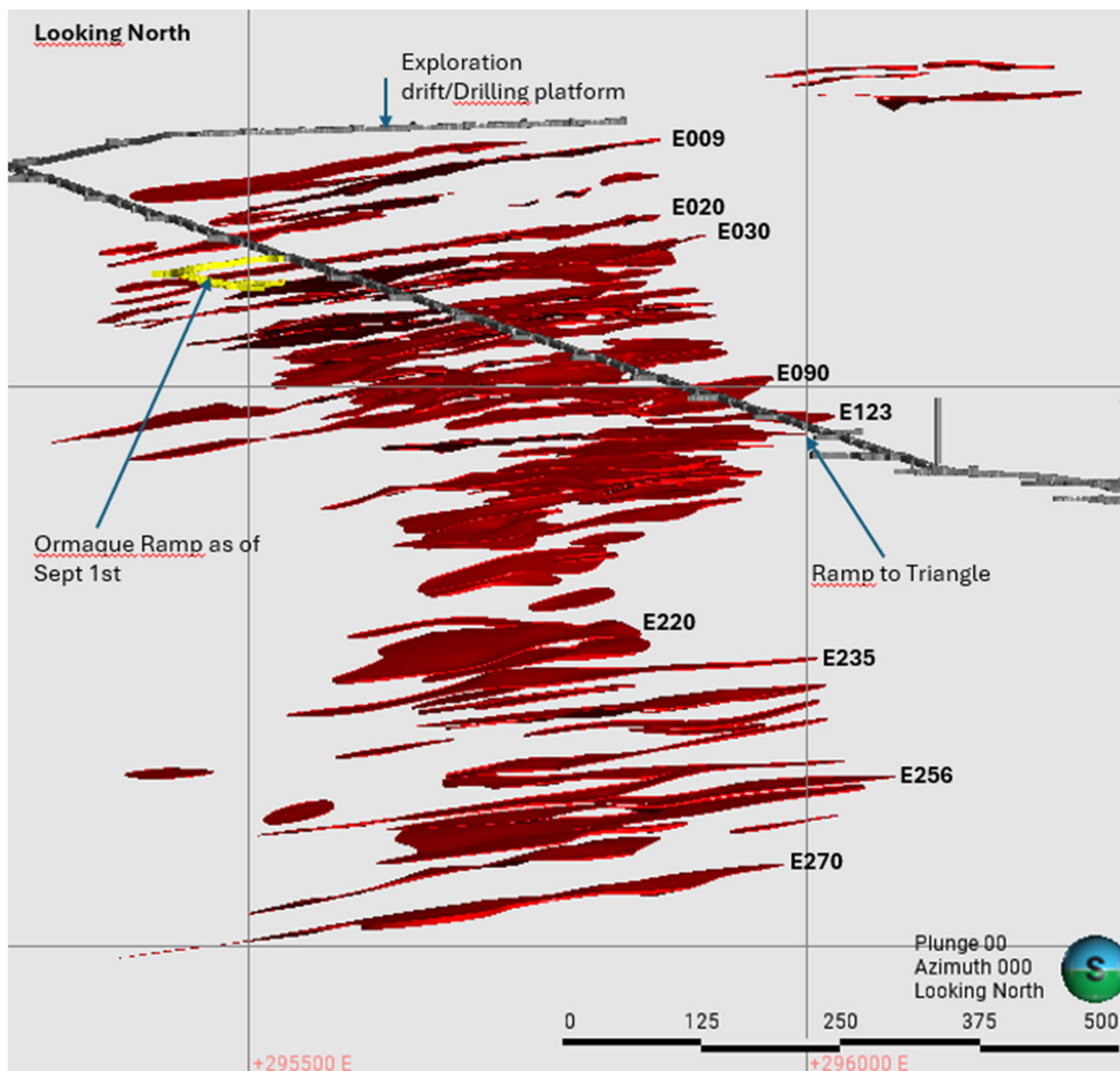

Figure 14-13: 3D Sectional View Looking North of the Modelled Resource Solids Associated with the Extension Zones at Ormaque (Eldorado 2024)

### 14.4.3 Data Analysis

The mineralized domains were reviewed to determine appropriate estimation or grade interpolation parameters. Several different procedures were applied to the data. Descriptive statistics, histograms and cumulative probability plots and box plots were completed for composite data. The results were used to guide the construction of the block model and the development of estimation plans including treatment of extreme grades. These analyses were conducted on 0.5 m composites of the assay data. The statistical properties from this analysis are summarized for capped and uncapped data in Table 14-17 and Table 14-18 for the Ormaque deposit.

Table 14-17: Ormaque Composite Statistics for 0.5 m Uncapped Composite Au (g/t) Data

Name	Count	Mean	SD	CV	Variance	Min	Q25	Q50	Q75	Max
E006	52	9.57	21.46	2.24	460.37	0.050	1.55	2.82	9.21	131.66
E007	36	5.58	11.37	2.04	129.18	0.005	0.59	2.80	5.97	66.25
E008	109	6.66	7.57	1.14	57.33	0.000	0.97	3.95	8.75	31.18
E008.5	432	4.65	12.51	2.69	156.49	0.002	0.01	0.11	2.89	134.50
E008.7	177	15.05	3.10	2.60	1528.86	0.002	0.14	2.04	8.89	300.00
E009	686	18.45	43.09	2.34	1856.58	0.002	0.14	3.36	19.70	567.30
E009.5	69	12.25	21.80	1.78	475.09	0.009	0.67	3.91	16.20	126.50
E010	262	8.55	25.41	2.97	645.61	0.002	0.12	1.18	5.27	302.00
E013	359	8.84	16.53	1.87	273.40	0.002	0.17	2.01	9.94	135.50
E020	535	13.73	29.89	2.18	893.65	0.002	0.53	4.09	11.93	248.00
E030	616	25.11	55.31	2.20	3059.5	0.002	0.57	5.71	25.1	611.00
E033	55	11.63	14.99	1.29	224.63	0.007	3.10	5.18	14.30	68.10
E040	642	19.25	37.41	1.94	1399.51	0.002	0.76	5.98	20.32	381.00
E043	28	16.08	23.50	1.46	552.17	0.005	1.85	7.74	15.32	104.50
E050	653	18.18	34.90	1.92	1218.29	0.002	1.02	6.04	20.50	450.00
E055	343	10.74	21.85	2.03	477.27	0.002	0.32	2.93	11.00	233.00
E060	292	11.80	22.03	1.87	485.15	0.002	0.72	4.08	12.95	209.00
E070	236	16.13	32.48	2.01	1054.72	0.002	0.71	6.12	15.20	288.16
E075	70	10.10	12.31	1.22	151.64	0.015	0.80	5.22	15.20	67.52
E080	299	14.49	25.90	1.79	670.99	0.008	0.66	3.98	14.48	158.50
E085	155	12.95	28.93	2.23	836.82	0.006	1.04	3.82	12.88	169.40
E090	309	13.96	40.80	2.92	1664.96	0.002	0.29	3.89	13.95	573.60
E100	272	12.23	25.22	2.06	636.07	0.002	0.68	3.61	11.85	261.10
E105	146	12.08	20.93	1.73	438.02	0.010	0.08	1.05	15.65	109.00
E110	222	18.14	29.98	1.65	898.90	0.002	0.53	5.78	22.20	191.47
E120	130	15.98	30.80	1.93	948.74	0.009	1.30	6.01	20.10	246.40
E123	42	12.83	14.61	1.14	213.45	0.015	1.18	5.85	19.30	60.50
E125	210	22.21	42.04	1.89	1767.70	0.002	0.81	5.03	23.25	282.00
E130	186	24.85	57.37	2.31	3291.45	0.007	1.89	7.01	23.30	555.00
E133	77	8.65	13.60	1.57	185.01	0.018	1.18	4.03	8.70	63.40
E135	131	9.07	22.38	2.47	500.80	0.002	0.07	1.49	7.24	164.78
E140	178	15.42	26.28	1.70	690.73	0.002	0.77	5.08	19.41	212.93
E145	153	13.58	33.29	2.45	1108.26	0.010	0.16	4.05	9.49	297.00
E150	71	13.08	20.66	1.58	427.00	0.010	1.58	5.18	13.59	102.50
E160	64	14.60	47.19	3.23	2227.22	0.008	0.32	2.90	9.23	369.08
E165	45	16.31	18.24	1.12	332.59	0.022	2.33	10.00	21.20	73.08
E170	44	9.99	13.19	1.32	173.90	0.041	1.53	3.74	15.61	44.32
E175	24	5.76	6.60	1.15	43.49	0.005	0.23	3.58	9.58	21.70

Name	Count	Mean	SD	CV	Variance	Min	Q25	Q50	Q75	Max
E195	21	10.41	22.32	2.14	498.19	0.005	1.12	3.59	8.43	95.57
E200	19	8.22	18.75	2.28	351.60	0.013	0.02	0.22	3.77	76.93
E210	18	20.97	68.68	3.27	4717.44	0.040	0.85	2.03	8.34	296.29
E220	60	10.46	27.83	2.66	774.60	0.002	0.06	0.79	4.41	147.49
E230	45	18.61	33.93	1.82	1151.22	0.005	0.36	6.10	19.50	189.42
E231	14	6.43	5.50	0.86	30.25	0.005	1.67	6.37	9.39	20.58
E235	96	10.56	19.30	1.83	372.42	0.002	0.08	1.89	9.79	96.58
E236	13	52.49	70.06	1.33	4908.20	0.344	6.47	18.99	58.97	207.00
E237	49	6.90	19.71	2.84	388.48	0.005	0.02	0.34	3.64	116.00
E240	53	12.81	31.12	2.43	968.54	0.005	0.08	2.71	8.03	185.61
E245	41	21.58	31.73	1.47	1007.03	0.002	3.82	9.90	22.42	136.55
E250	72	14.02	18.27	1.30	333.63	0.005	0.66	7.84	19.11	79.96
E255	67	13.64	40.20	2.95	1615.77	0.005	0.07	3.32	11.33	308.92
E256	50	9.87	14.08	1.43	198.17	0.032	0.65	3.18	13.49	66.07
E260	62	15.89	19.77	1.24	390.79	0.005	2.31	5.54	28.97	101.75
E265	32	22.22	73.62	3.31	5420.60	0.070	0.56	3.51	7.73	389.44
E270	38	12.27	36.86	3.00	1358.88	0.005	0.75	3.31	6.91	226.07

**Table 14-18: Ormaque Composite Statistics for 0.5 m Capped Composites of Au (g/t) Data (70 g/t capping)**

Name	Count	Mean	SD	CV	Variance	Min	Q25	Q50	Q75	Max
E006	52	8.19	14.81	1.81	219.38	0.050	1.55	2.82	9.21	70.00
E007	36	5.58	11.37	2.04	129.18	0.005	0.59	2.80	5.97	66.25
E008	104	6.96	7.60	1.09	57.82	0.020	1.08	4.68	9.24	31.18
E008.5	432	4.49	11.23	2.50	126.11	0.002	0.01	0.11	2.89	70.00
E008.7	177	10.15	18.31	1.80	335.18	0.002	0.14	2.04	8.89	70.00
E009	686	13.46	20.10	1.49	403.84	0.002	0.14	3.36	18.70	70.00
E009.5	69	10.71	15.48	1.45	239.48	0.009	0.67	3.91	16.20	70.00
E010	262	6.76	14.32	2.12	205.20	0.002	0.12	1.18	5.27	70.00
E013	359	8.35	14.17	1.70	200.91	0.002	0.17	2.01	9.94	70.00
E020	535	10.93	17.48	1.60	305.60	0.002	0.43	4.09	11.90	70.00
E030	616	17.07	22.70	1.33	515.48	0.002	0.57	5.71	25.1	70.00
E033	55	11.63	14.99	1.29	224.63	0.007	3.10	5.18	14.30	68.10
E040	642	14.83	19.95	1.34	398.01	0.002	0.76	5.98	20.11	70.00
E043	28	14.93	19.51	1.31	380.61	0.005	1.85	7.74	15.32	70.00
E050	653	14.17	18.59	1.31	345.54	0.002	1.01	6.04	20.20	70.00
E055	343	9.65	15.40	1.60	237.26	0.002	0.32	2.93	11.00	70.00
E060	292	10.45	15.45	1.48	238.76	0.002	0.72	4.08	12.95	70.00
E070	236	12.51	17.04	1.36	290.50	0.002	0.71	6.12	15.20	70.00

Name	Count	Mean	SD	CV	Variance	Min	Q25	Q50	Q75	Max
E075	70	9.93	11.68	1.18	136.48	0.015	0.80	5.22	15.20	57.84
E080	299	12.47	18.88	1.51	356.41	0.008	0.66	3.98	14.48	70.00
E085	155	9.80	14.15	1.44	200.13	0.006	1.04	3.82	12.88	70.00
E090	309	10.85	16.45	1.52	270.61	0.002	0.29	3.89	13.95	70.00
E100	272	10.49	16.10	1.53	259.33	0.002	0.68	30.61	11.80	70.00
E105	146	11.13	17.61	1.58	309.99	0.010	0.08	1.05	15.65	70.00
E110	222	15.54	20.85	1.34	434.67	0.002	0.53	5.78	21.78	70.00
E120	130	13.18	17.12	1.30	292.97	0.009	1.30	6.01	20.10	70.00
E123	42	12.83	14.61	1.14	213.45	0.015	1.18	5.85	19.30	60.50
E125	210	16.27	22.10	1.36	488.28	0.002	0.81	5.03	23.25	70.00
E130	186	16.65	21.24	1.28	451.26	0.007	1.89	6.95	22.02	70.00
E133	77	8.65	13.60	1.57	185.01	0.018	1.18	4.03	8.70	63.40
E135	131	7.28	13.64	1.87	185.97	0.002	0.08	1.49	7.24	70.00
E140	178	13.80	19.51	1.41	380.57	0.002	0.77	5.08	19.41	70.00
E145	153	10.02	17.61	1.76	310.01	0.010	0.16	4.05	9.27	70.00
E150	71	12.29	17.80	1.45	316.90	0.010	1.58	5.18	13.59	70.00
E160	64	9.70	15.94	1.64	254.23	0.008	0.32	2.90	9.23	68.10
E165	45	15.86	17.25	1.09	297.62	0.022	2.33	10.00	21.20	68.19
E170	44	9.99	13.19	1.32	173.90	0.041	1.53	3.74	15.61	44.32
E175	24	5.76	6.60	1.15	43.49	0.005	0.23	3.58	9.58	21.70
E195	21	9.18	17.60	1.91	309.74	0.005	1.12	3.59	8.43	70.00
E200	19	7.77	17.35	2.23	300.92	0.013	0.02	0.22	3.77	70.00
E210	18	8.54	16.76	1.96	281.04	0.040	0.85	2.03	8.34	70.00
E220	60	7.92	17.60	2.22	309.78	0.002	0.06	0.79	4.41	70.00
E230	45	15.11	21.29	1.41	453.44	0.005	0.36	6.10	19.50	70.00
E231	14	6.43	5.50	0.86	30.25	0.005	1.67	6.37	9.37	20.58
E235	96	10.12	17.73	1.75	314.28	0.002	0.08	1.89	9.79	70.00
E236	13	26.55	25.95	0.98	673.21	0.340	6.47	18.95	50.41	70.00
E237	49	5.99	14.94	2.49	223.18	0.005	0.02	0.34	3.64	70.00
E240	53	9.60	17.59	1.83	309.42	0.005	0.08	2.71	8.03	70.00
E245	41	17.54	19.31	1.10	372.95	0.002	3.82	9.90	22.42	70.00
E250	72	13.88	17.78	1.28	316.26	0.005	0.66	7.84	19.11	70.00
E255	67	8.83	14.61	1.65	213.44	0.005	0.07	3.32	11.33	70.00
E256	50	9.87	14.08	1.43	198.17	0.033	0.65	3.18	13.49	66.07
E260	62	15.29	17.82	1.17	317.60	0.005	2.31	5.54	28.97	70.00
E265	32	8.95	17.07	1.91	297.37	0.070	0.56	3.51	7.73	70.00
E270	38	7.49	12.96	1.73	168.02	0.005	0.75	3.31	6.91	61.97

#### 14.4.4 Evaluation of Extreme Grades

Extreme gold grades were examined using histograms and cumulative probability plots. This analysis showed that a risk does exist with respect to extreme gold grades at Ormaque. To mitigate this risk, gold grades were capped to 70 g/t in the assay data prior to compositing. Statistical study of capping shows a metal loss between 3.9-8.8% for the domains. This metal cut is accepted since there was no access to underground prior to evaluation. Due to the very thin nature of Ormaque veins and the unknown effect of dilution due to mining a 3m thickness, a conservative approach was chosen. During grade interpolation, an outlier restriction was also used in a few domains to limit the effects of high-grade composites locally to prevent overestimation due to sparse high-grade values.

#### 14.4.5 Variography

Variography, a continuation of data analysis, is the study of the spatial variability between pairs of points at various distances. The Ormaque veins all have very similar attitude (dip, azimuth and direction of ore shoots) therefore all the veins were used in a single variogram using the Edge module in Leapfrog Geo. Variogram model parameters are shown in Table 14-19.

**Table 14-19: Variogram Parameters for Ormaque Mineralization Zones**

Domain	C <sub>0</sub>	C <sub>1</sub>	Dip/A/Pitch	Range Mj	Range Sm	Range
All Veins	0.4	0.6	8/243/95	30.7	27.7	3.3

Note: Model is spherical

#### 14.4.6 Bulk Density

A constant bulk density of 2.71 g/cm<sup>3</sup> was used for the Ormaque deposit. This is based on measurements taken since 2019.

#### 14.4.7 Model Set-up

Eldorado carried out the grade estimation using Seequent's LeapFrog Edge software. The block size for the Lamaque models was in part selected based on mining selectivity considerations (underground mining) and shown in Table 14-20.

The assays were capped to 70 g/t Au and then combined into 0.5 m fixed-length downhole composites, within the boundaries of the individual modelled extension veins. If residual end length intervals were less than 0.25 m, they were distributed equally on the preceding intervals. A second set of 5 m composites was created for model validation purposes. For 5 m composites, if residual lengths were less than 2.5 m, they are also distributed equally on the preceding intervals.

Estimation setups were prepared individually for each of the mineralized domains; each estimation only considered composites within that domain. Each setup and its respective 3D domain shape used to generate an individual sub-blocked model for each domain. After each individual vein model passed its validation steps, estimation setups were combined into a single setup and a final combined model was created.

**Table 14-20: Block model Limits and block definitions**

	Base Point	Parent Block (m)	Sub-Block Count	No. of Parent Block	Boundary Size
<b>East</b>	295 240	5	5	206	1030
<b>North</b>	5 330 000	5	5	117	585
<b>Elevation</b>	305	5	Variable Height	173	865

### 14.4.8 Estimation

Grade modelling consisted of interpolation by ordinary kriging (OK) and Inverse Distance Weighting (IDW) to the power of 2 or 4 with 0.5 m composites. Kriging was used for domains that have sufficient drilling, mainly in the upper portion of the deposit. Inverse distance interpolation was used for the remaining zones, largely due to the limited data in these domains. Nearest-neighbour (NN) grades were also interpolated for validation purposes using the 5 m composite data set. Blocks and composites were created within mineralized domains. Parameters for estimations are shown in Table 14-21.

For the OK interpolation, the maximum number of composites required for the interpolation varied between 5 to 24. The minimum number of composites required from a single was set to 1 sample. For each block, the number of samples, the number of drillholes used and the average distance of the samples used in estimation were stored for use in the mineral resource classification process.

The search ellipsoids were oriented preferentially to match the orientation of the respective 3D mineralized domain. The ellipsoid dimensions were guided by the size of the respective domain.

In some of the domains, an outlier restriction was used to limit the effects of high-grade composites locally. The outlier values used varied from 10 g/t Au to 50 g/t Au. Size of the search ellipsoid was clamped from 30% to 80% of its original to restrict the outlier values.

**Table 14-21: Estimation Plan for Ormaque Zones**

Domain	Estimation	Search Radius			Nb of Samples		Drillhole Limit	Outlier Restrictions		
		Mj	Sm	Mn	Min	Max	Max	Method	Distance	Threshold
E006	IDW4	60	60	60	1	14		None		
E007	OK	50	40	30	1	7	2	Clamp	50	40
E008.5	IDW4	80	40	20	1	9	3	None		
E008.7	OK	50	40	30	1	9		None		
E009	IDW2	60	60	60	1	24	4	None		
E009.5	OK	30	30	15	1	12	3	None		
E010	OK	73.45	40	30	1	9	3	None		
E013	OK	47.92	25.44	34.29	1	9		None		
E020	OK	60	60	30	1	7	3	None		
E030	OK	76.97	45.9	28.85	1	9	3	None		
E033	OK	50	50	15	1	9	3	None		
E040	OK	105.61	43.44	30	1	15	5	Clamp	50	50
E043	IDW2	50	50	20	1	12	3	None		
E050	OK	60	60	60	1	12	3	Clamp	40	40
E055	OK	38.89	40	25	1	12		None		
E060	OK	65	40	25	1	10	3	Clamp	50	40
E070	IDW2	46.35	45.78	60	1	9	3	Clamp	40	40
E075	OK	65	47.57	25	1	10		Clamp	50	40

Domain	Estimation	Search Radius			Nb of Samples		Drillhole Limit	Outlier Restrictions		
		Mj	Sm	Mn	Min	Max	Max	Method	Distance	Threshold
E080	OK	41.94	35.92	25	1	9		None		
E085	OK	53.52	30.44	25	1	8	3	None		
E090	OK	65	40	25	1	15		None		
E100	IDW2	90	101.6	50	1	7		None		
E105	IDW2	36.18	26.49	8.85	1	5	2	None		
E110	OK	94.96	30.85	22.26	1	8		None		
E120	OK	65	40	25	1	9		Clamp	50	50
E123	IDW2	81.43	68.86	60	1	8		None		
E125	OK	65	40	25	1	10	3	Clamp	70	50
E130	OK	56.75	53.99	41.15	1	12	4	Clamp	80	25
E133	IDW2	84.85	60.39	60	1	10		None		
E135	OK	65	40	25	1	12		Clamp	40	40
E140	OK	65	40	25	1	10	3	Clamp	60	50
E145	OK	65	66.2	32.98	1	10	2	None		
E150	IDW2	60	60	60	1	9		None		
E160	IDW2	71.79	38.84	27.08	1	12	2	None		
E165	OK	59.73	42.25	25	1	9		None		
E170	IDW2	60	60	60	1	11		Clamp	35	20
E175	IDW2	60	60	60	1	15	3	Clamp	40	40
E195	OK	76.01	46.86	45	1	10		Clamp	55	13
E200	OK	50	50	50	1	10		Clamp	55	13
E210	IDW2	50	50	50	1	15	3	Clamp	40	40
E220	IDW2	60	60	60	1	10		None		
E230	IDW2	92.71	116.87	60	1	15	3	Clamp	40	40
E231	OK	65	45.79	25	1	10		Clamp	35	10
E235	IDW2	60	76.49	60	1	15		Clamp	55	40
E236	IDW2	60	40	20	1	15		Clamp	55	40
E237	IDW2	80	80	30	1	15		Clamp	55	40
E240	IDW2	60	60	60	1	15		Clamp	45	40
E245	IDW2	120	80	30	1	15		Clamp	45	40
E250	OK	100	60	20	1	10		Clamp	30	40
E255	IDW2	120	80	20	1	15		Clamp	45	40
E256	IDW2	120	80	20	1	15		Clamp	45	40
E260	IDW4	160	120	30	1	9		Clamp	45	40
E265	IDW2	120	80	30	1	15		Clamp	45	40
E270	IDW2	120	120	30	1	15		Clamp	45	40

## 14.4.9 Validation

### 14.4.9.1 Visual Inspection

Eldorado completed a detailed visual validation of the Ormaque resource model. The domains were checked for proper coding of drillhole intervals and block model cells, in both 3D and plan views. Coding was found to be accurate. Block grade interpolation was examined relative to drillhole composite values by inspecting cross-sections and plans. The checks showed good agreement between local drillhole composite values, and the block model values. The hard boundaries appear to have constrained grades to their respective estimation domains. The addition of the outlier restriction values succeeded in minimizing grade smearing in regions of sparse data. Representative plans containing block model grades, drill hole composite values, and domain outlines are shown in Figure 14-14 to Figure 14-16.

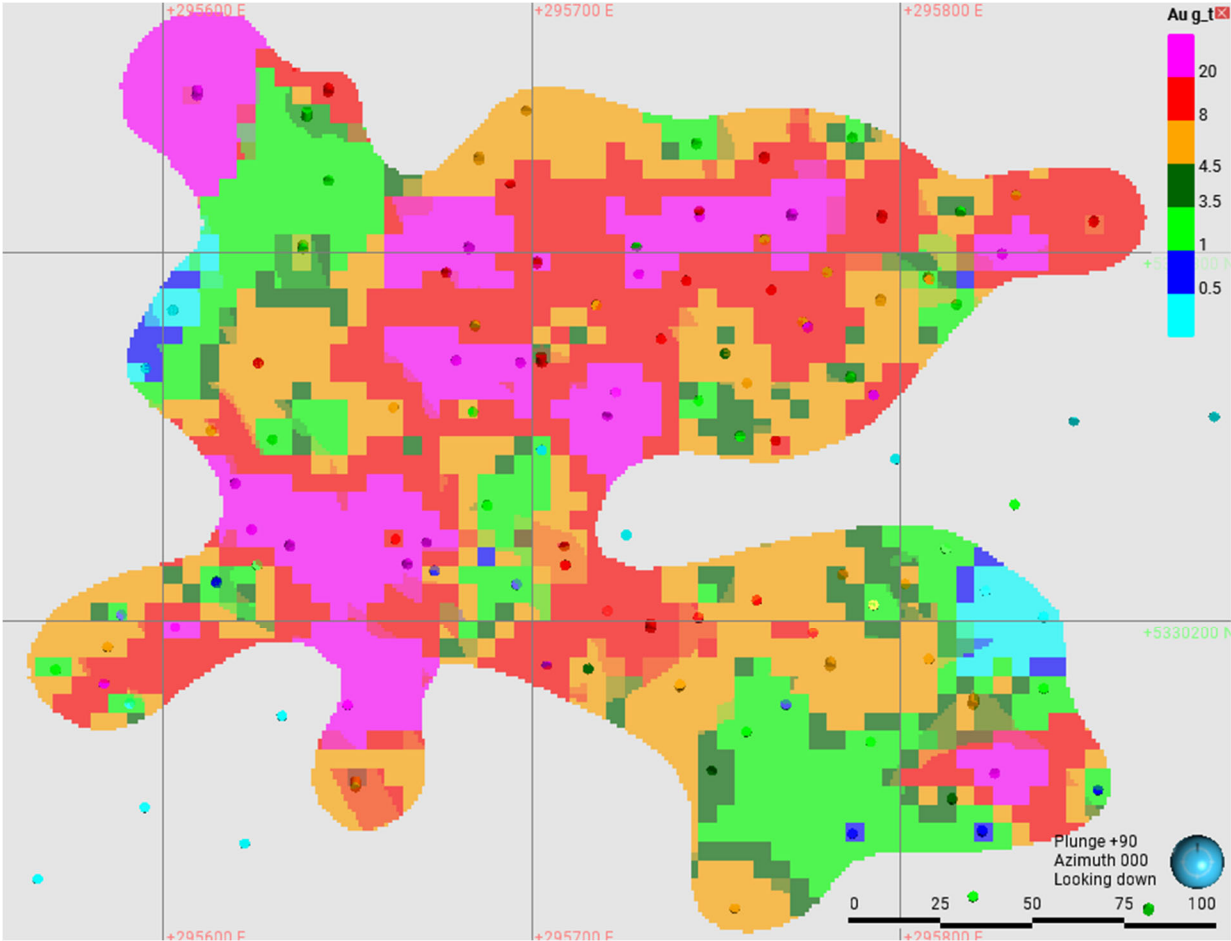

Figure 14-14: Zone E0100 Showing Gold Composite Data and Gold Block Model (Eldorado 2024)

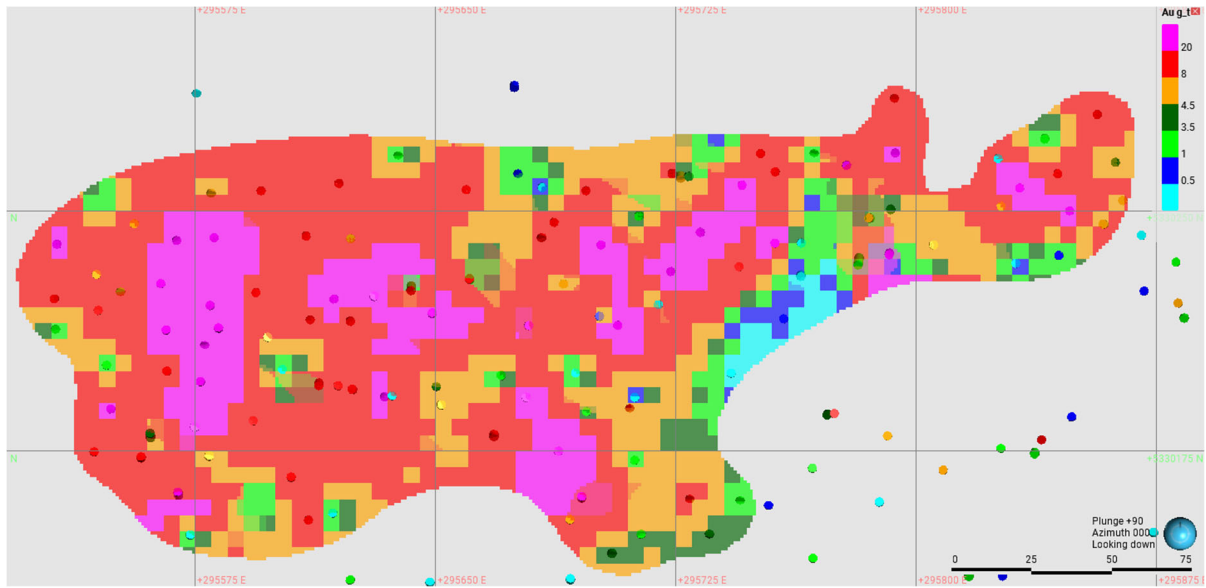

Figure 14-15: Zone E070 Showing Gold Composite Data and Gold Block Model (Eldorado 2024)

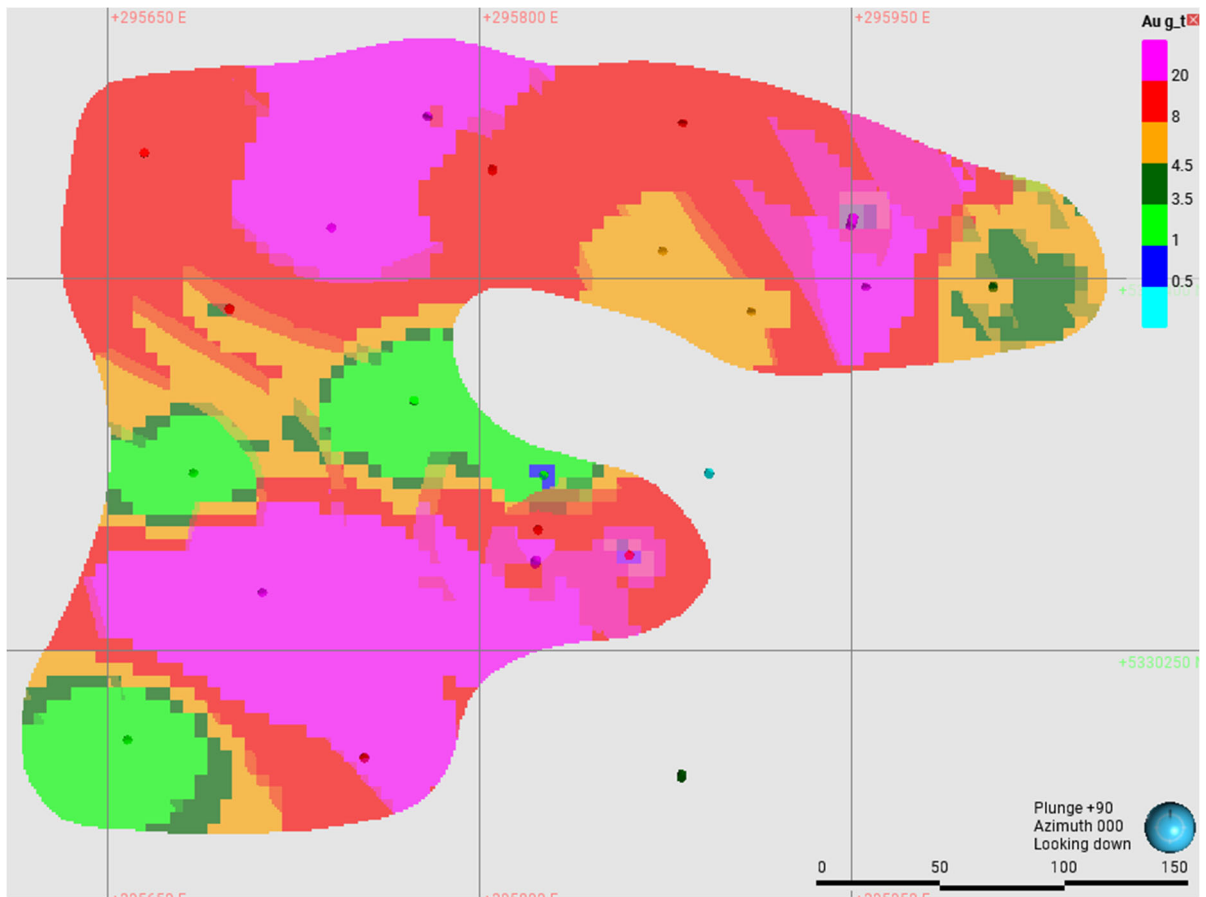

Figure 14-16: Zone E260 Showing Gold Composite Data and Gold Block Model (Eldorado 2024)

#### 14.4.9.2 Model Checks for Bias

The block model estimates were checked for global bias by comparing the average metal grades (with no cut-off) from the model with means from NN estimates. The NN estimator declusters the data and produces a theoretically unbiased estimate of the average value when no cut-off grade is imposed and is a good basis for checking the performance of different estimation methods. Results, summarized in Table 14-22, show some over or underestimation in some domains. However, in total there is no bias (<5%). Further analysis shows that only 20% of ounces with indicated are slightly underestimated and only 5% of ounces with indicated are slightly overestimated. Lastly, the zones with highest resource potential show no bias (E020, E030, E040, E050). With ongoing drilling, modeling and the start of underground development, the precision will improve.

**Table 14-22: Global Model Mean Gold Values by Mineralized Domain, Ormaque Deposit**

Domain	Mean Estimate	Mean NN	Difference %
E006	8.56	9.10	-5.97
E007	4.05	6.17	-34.33
E008.5	7.44	7.97	-6.59
E008.7	9.33	8.34	11.87
E009	12.59	11.96	5.20
E009.5	14.79	17.21	-14.08
E010	10.61	10.07	5.36
E013	6.76	7.23	-6.59
E020	13.57	13.06	3.92
E030	15.62	15.63	-0.05
E033	12.82	13.45	-4.63
E040	14.61	14.70	-0.63
E043	11.43	10.67	7.07
E050	14.64	14.08	3.95
E055	9.71	9.64	0.73
E060	10.84	11.23	-3.45
E070	12.60	13.27	-5.02
E075	9.85	11.25	-12.48
E080	13.42	13.13	2.22
E085	10.18	11.10	-8.34
E090	11.58	12.15	-4.64
E100	10.97	11.73	-6.42
E105	13.76	12.28	12.08
E110	15.99	16.39	-2.46
E120	13.88	13.43	3.34
E123	14.48	16.40	-11.74
E125	15.09	15.78	-4.36
E130	15.56	15.86	-1.89
E133	9.06	9.05	0.07

Domain	Mean Estimate	Mean NN	Difference %
E135	6.81	7.80	-12.70
E140	15.08	15.48	-2.62
E145	13.24	12.88	2.75
E150	14.19	16.14	-12.10
E160	11.28	10.87	3.78
E165	16.67	15.68	6.32
E170	8.87	9.81	-9.58
E175	5.64	6.22	-9.20
E195	8.73	9.04	-3.40
E200	6.63	7.45	-11.03
E210	7.56	8.26	-8.47
E220	9.87	9.17	7.61
E230	19.66	20.30	-3.14
E231	5.38	7.08	-24.08
E235	11.42	13.35	-14.46
E236	23.84	23.50	1.46
E237	5.58	5.02	11.14
E240	9.35	10.49	-10.87
E245	18.78	19.05	-1.41
E250	14.17	13.45	5.37
E255	8.72	11.67	-25.29
E256	9.93	13.13	-24.40
E260	15.91	16.32	-2.52
E265	8.17	8.29	-1.48
E270	8.07	8.44	-4.34
TOTAL	11.62	12.06	-3.67

The Ormaque block model was also checked for local bias in the grade estimates by grade slice or swath checks. This was done by plotting the mean values from the NN estimate versus the OK results for benches and eastings. The OK estimate should be smoother than the NN estimate, thus the NN estimate should fluctuate around the kriged estimate on the plots. The observed trends, displayed in Figure 14-17 and Figure 14-18 behave as predicted and show no significant local bias in the OK Au estimates.

Swath Plot: E070

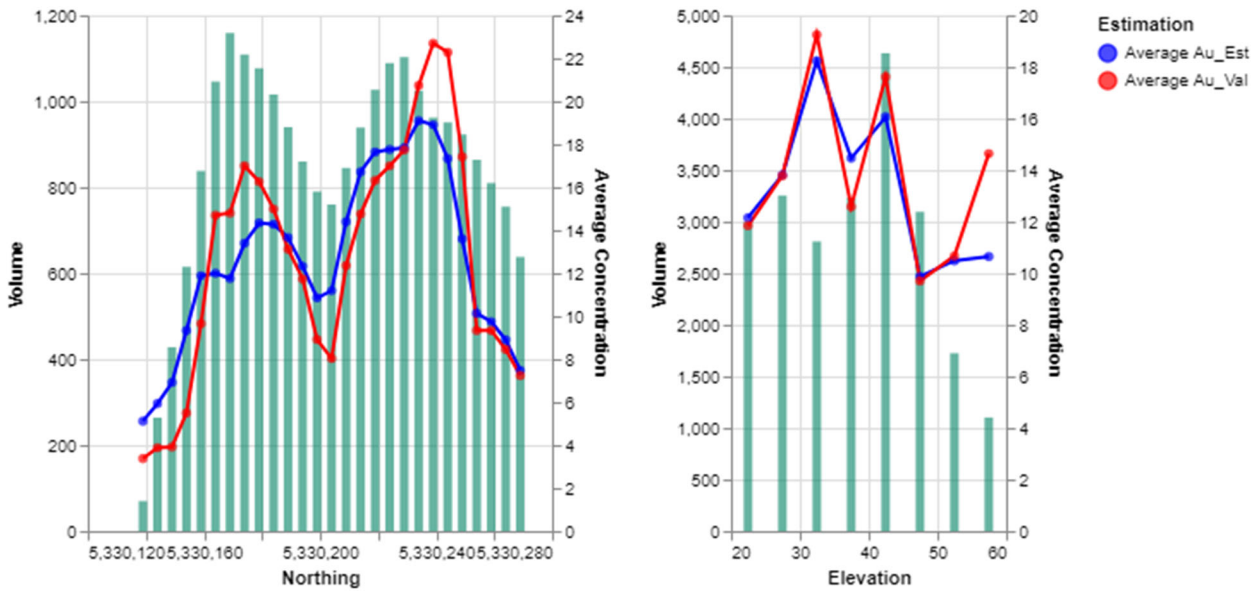
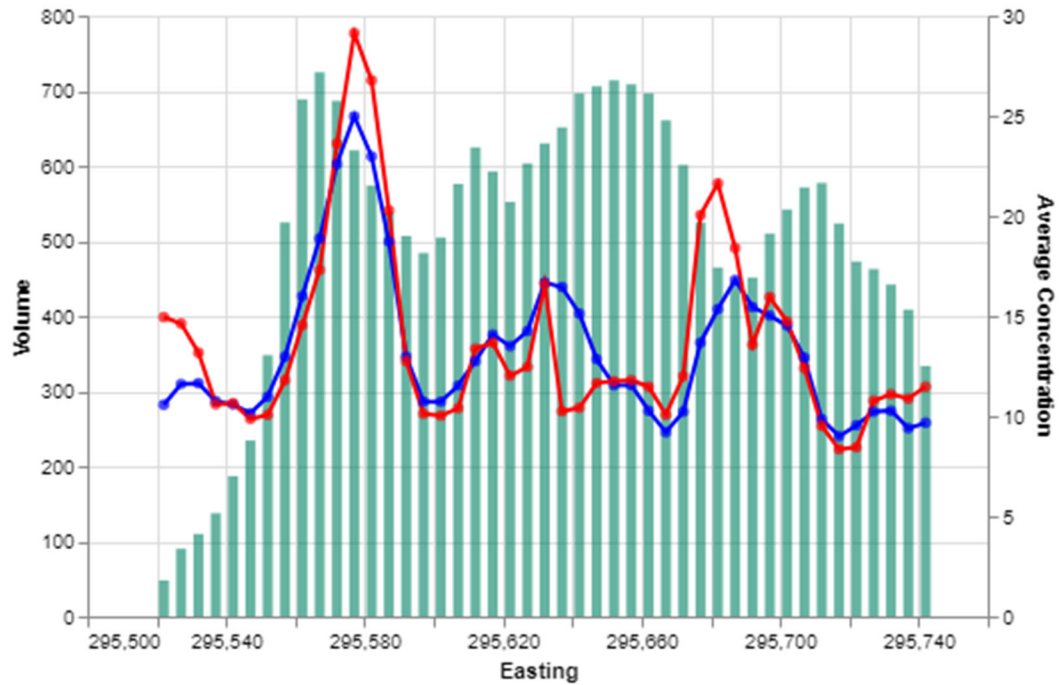
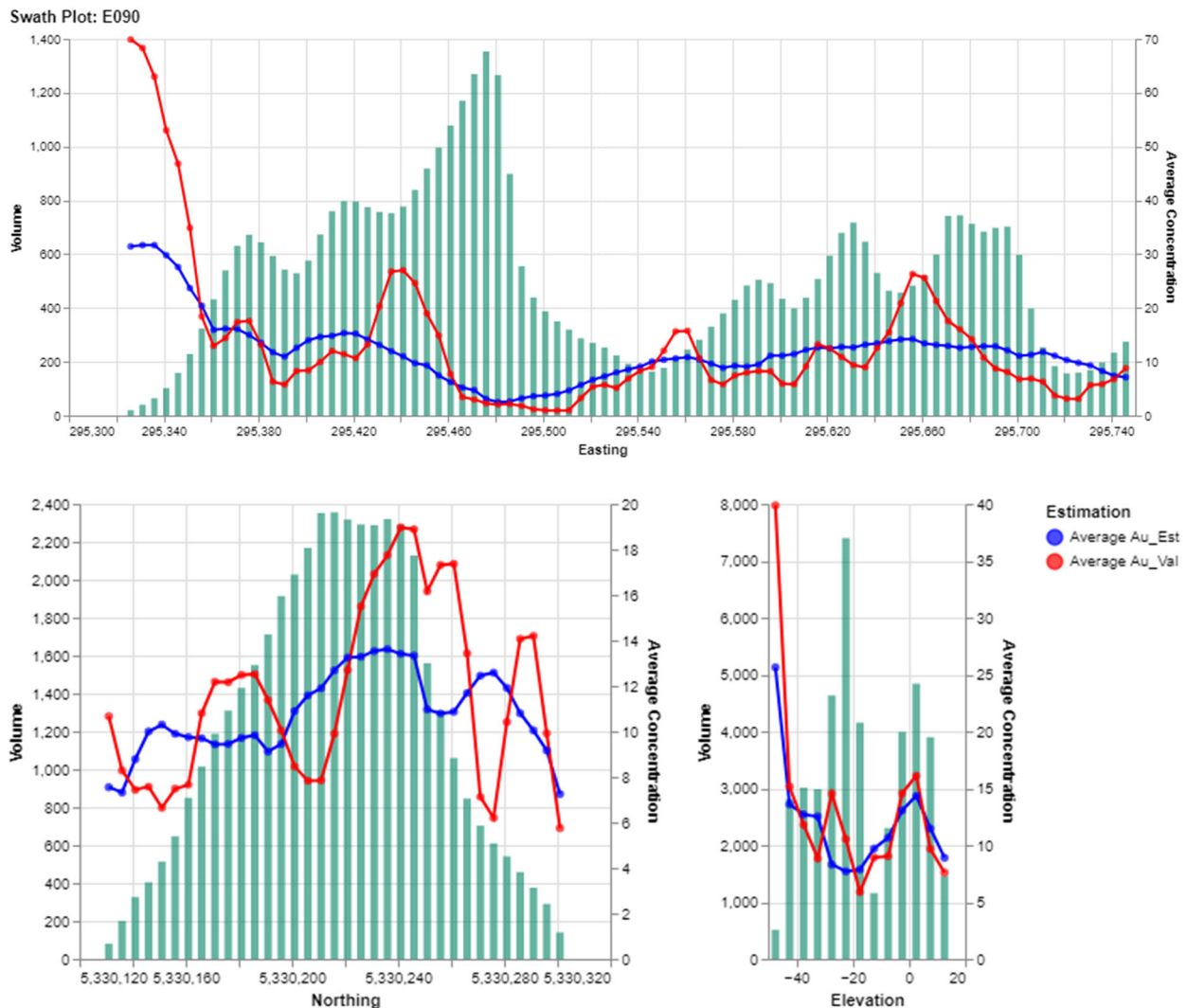

Figure 14-17: Model Trend Plots Showing 5 m Binned Averages Along Elevations and Eastings for Kriged (Au) and Nearest Neighbour Gold Grade Estimates, E070 Zone, Ormaque Deposit (Eldorado 2024)



**Figure 14-18: Model Trend Plots Showing 5 m Binned Averages Along Elevations and Eastings for Kriged (Au) and Nearest Neighbour Gold Grade Estimates, E090 Zone, Ormaque Deposit (Eldorado 2024)**

#### 14.4.10 Mineral Resource Classification

The Mineral Resources of the Ormaque deposit were classified using logic consistent with the CIM Definition Standards for Mineral Resources and Mineral Reserves referred to in NI 43-101. The density of drillhole data and the continuity of mineralization in the upper half of the deposit at Ormaque (domains E006 to E170) supports Indicated and Inferred Mineral Resources, where drillhole spacing is below 30 m for Indicated Mineral Resources. The lower part of the deposit (E175 to E270) only contains Inferred Mineral Resources.

#### 14.4.11 Mineral Resource Summary

The Mineral Resources for the Ormaque deposit, as of September 30, 2024, are shown in Table 14-23. The Mineral Resources are reported within the constraining volumes that were created to control resource reporting at a 3.5 g/t / 3 m gold cut-off grade. A breakdown of the Mineral Resources by zone are shown in Table 14-24.

**Table 14-23: Ormaque Mineral Resources, as of September 30, 2024**

Deposit Name	Categories	Tonnes (x 1,000)	Grade Au (g/t)	Contained Au (oz x 1,000)
Ormaque	Measured	3	7.76	1
	Indicated	1,414	16.44	747
	<b>Measured + Indicated</b>	<b>1,417</b>	<b>16.42</b>	<b>748</b>
	Inferred	1,749	14.87	837

Note: differences may occur in totals due to rounding

**Table 14-24: Ormaque Mineral Resources breakdown by zone, as of September 30, 2024**

Zone	Class	Tonnes (x 1,000)	Grade Au (g/t)	Contained Au (oz x 1,000)
Stockpile	Measured	3	7.76	1
E006	Inferred	16	13.44	7
E008	Inferred	45	9.22	13
E008.5	Indicated	12	18.25	7
E008.7	Indicated	8	17.70	5
E009.5	Indicated	8	11.87	3
E009	Indicated	72	14.58	34
	Inferred	16	19.63	10
E010	Indicated	2	17.29	1
E013	Indicated	46	11.48	17
	Inferred	32	13.07	14
E020	Indicated	58	17.88	33
	Inferred	16	20.09	10
E030	Indicated	89	20.28	58
	Inferred	3	18.21	2
E040	Indicated	134	15.36	66
	Inferred	23	13.69	10
E050	Indicated	140	16.89	76
E055	Indicated	44	13.90	20
	Inferred	0	14.13	0
E060	Indicated	45	13.61	19
E070	Indicated	41	16.97	23
	Inferred	2	13.84	1
E075	Indicated	18	10.99	6
E080	Indicated	75	15.01	36
	Inferred	1	20.99	1
E085	Indicated	18	17.46	10
	Inferred	2	22.04	1

Zone	Class	Tonnes (x 1,000)	Grade Au (g/t)	Contained Au (oz x 1,000)
E090	Indicated	73	15.73	37
	Inferred	24	15.07	12
E100	Indicated	49	13.92	22
	Inferred	22	18.65	13
E105	Indicated	48	15.75	24
	Inferred	4	15.28	2
E110	Indicated	58	21.67	41
	Inferred	9	23.98	7
E120	Indicated	31	18.64	18
	Inferred	26	16.29	14
E123	Indicated	11	19.67	7
	Inferred	6	22.83	4
E125	Indicated	70	19.31	43
	Inferred	9	15.01	4
E130	Indicated	83	18.34	49
	Inferred	11	12.53	5
E133	Indicated	19	12.94	8
	Inferred	2	11.85	1
E135	Indicated	13	12.89	5
	Inferred	10	15.22	5
E140	Indicated	63	17.71	36
	Inferred	21	12.47	8
E145	Indicated	48	12.73	19
	Inferred	38	17.63	22
E150	Indicated	12	22.06	8
	Inferred	15	24.13	12
E160	Indicated	11	16.21	6
	Inferred	6	19.31	4
E165	Inferred	27	19.66	17
E170	Indicated	3	19.16	2
	Inferred	9	13.20	4
E175	Inferred	2	4.11	0
E195	Inferred	44	9.96	14
E220	Inferred	72	14.45	33
E230	Inferred	66	20.20	43
E231	Inferred	18	5.36	3
E235	Inferred	109	16.71	59
E240	Inferred	23	29.80	22

Zone	Class	Tonnes (x 1,000)	Grade Au (g/t)	Contained Au (oz x 1,000)
E033	Indicated	10	13.86	4
E043	Indicated	2	30.82	2
E236	Inferred	16	25.58	13
E237	Inferred	48	9.14	14
E245	Inferred	68	21.05	46
E250	Inferred	174	14.24	80
E255	Inferred	133	10.49	45
E256	Inferred	99	12.63	40
E260	Inferred	245	17.93	141
E265	Inferred	82	10.98	29
E270	Inferred	129	10.57	44
	Total	160	10.41	53
E200	Inferred	26	8.75	7
E210	Inferred	3	32.49	3
<b>Total</b>	Measured	3	10.37	1
	Indicated	1 414	16.44	747
	<b>M&amp;I</b>	<b>1 417</b>	<b>16.42</b>	<b>748</b>
	<b>Inferred</b>	<b>1 750</b>	<b>14.87</b>	<b>837</b>

There are no foreseen legal, political, environmental, environmental, permitting, title, taxation, socio-economic, marketing, political, or other risks or relevant factors that could materially affect the Mineral Resource estimates.

## 15 Mineral Reserve Estimates

Mineral Reserves are the economically mineable portion of a Measured or Indicated Mineral Resource. Dilution and allowances for losses from the mining and extraction processes are included and supported by prefeasibility-level assessments, including the use of appropriate modifying factors.

Proven Mineral Reserves are the economically mineable portion of Measured Mineral Resources. The Proven Mineral Reserves are based on a high degree of confidence in the Modifying Factors. Probable Mineral Reserves are the economically mineable portion of Indicated Mineral Resources. The confidence in the modifying factors applied to Probable Mineral Reserves is lower than that applying to Proven Mineral Reserves.

The Mineral Reserve estimate is based on Measured and Indicated Mineral Resources within the Triangle, Ormaque, and Parallel deposits upon which the mining plan and economic study have demonstrated economical extraction.

The Mineral Reserves cut-off grade is calculated using a gold price of US\$1,450/oz and an exchange rate of CAD\$ / US\$1.33. Different cut-off grades were determined based on the mining method, as presented in Table 15-1 and Table 15-3.

The costs supporting the analysis of the breakeven cut-off grades were compiled from the 2023 to 2024 actual costs updated to reflect the unit costs of a steady-state production of 900,000 tonnes per year, as presented in Table 15-1 and Table 15-3.

**Table 15-1: Long Hole Cut-off Grade Definition (Triangle and Parallel deposits)**

Description	Unit Cost US\$/t	Cut-off Grade g/t
Mining	89.46	1.98
Process	23.64	0.52
G&A	26.60	0.59
Sustaining Capital	80.85	1.79
Transport & Refining	0.40	0.01
Royalty	4.67	0.10
<b>Total</b>	<b>225.61</b>	<b>4.99</b>
Gold recovery	%	97.0
Gold Price	US\$	1 450
Breakeven Grade	g/t Au	4.99
Cut-off Grade Applied to Resources	g/t Au	3.5

**Table 15-2: Drift-And-Fill Cut-off Grade Definition (Ormaque deposit)**

Description	Unit Cost US\$/t	Cut-off Grade g/t
Mining	126.04	2.83
Process	23.64	0.53
G&A	26.61	0.60
Sustaining Capital	71.49	1.60
Transport and Refining	0.40	0.01

Description	Unit Cost US\$/t	Cut-off Grade g/t
Royalty	4.67	0.10
<b>Total</b>	<b>252.85</b>	<b>5.67</b>
Gold recovery	%	95.6
Gold Price	\$US	1 450
Breakeven Grade	g/t Au	5.67
Cut-off Grade Applied to Resources	g/t Au	3.5

## 15.1 Factors that May Affect Mineral Reserves

Areas of uncertainty that may materially impact the Mineral Reserve estimates include, but are not restricted to, the following items:

- Gold market price and exchange rate.
- Gold market price below US\$1,450/oz or an exchange rate below CAD\$ / US\$1.33 may result in reclassification of some of the Mineral Reserves due to reduced revenue and/or operating margin.
- Costs assumptions, in particular cost escalation.
- Increased capital or operating costs beyond the assumptions utilized may result in reclassification of some of the Mineral Reserves due to reduced operating margin.
- Geological complexity and continuity.
- Geological complexity and continuity that differs from the Geological Models utilized may result in reclassification of some of the Mineral Reserves due to reduced ore tonnages based on minimum mining shapes or cut-off grade
- Dilution and recovery factors.
- Higher dilution and/or lower mining or metallurgical recovery factors may result in reclassification of some of the Mineral Reserves due to higher operating costs and/or reduced revenue and/or operating margin
- Geotechnical assumptions concerning rock mass stability.
- Poorer geotechnical conditions may result in reclassification of some of the Mineral Reserves due to higher operating costs associated with different mining methods, ground control, or other implications

Additionally, Mineral Reserves Estimates may be materially impacted if mining or processing rates could not be maintained at forecasted levels, if critical infrastructure were to become unavailable, or if current permits were rescinded.

## 15.2 Underground Resource Estimates

The Mineral Resources model was provided by a joint effort between mine geology and the exploration team and served as the basis for calculating mineable tonnage and metal content in the mine plan. Resource wireframes were produced on LeapFrog Geo software and an interpolated block model was produced by Edge Software. Using Deswik Stope Optimizer Module, stope shapes were created using the following constraints and modifying factors:

- Long Hole Mining (Triangle and Parallel deposits)
- Vertical Height: 25 m
- Minimum dip 45°
- Between 3 m and 7 m thickness → Longitudinal Retreat
- More than 7 m thickness with sufficient continuity → Transverse Primary / Secondary

- External dilution of 25%
- Mining recovery of 95%
- Ore development included in Mineral Reserves considered 100% mining recovery and no overbreak dilution
- Ore development below breakeven cut-off grade but higher than 3.0 g/t was included as Mineral Reserves material if development was mandatory.
- Metallurgical recovery of 97%
- Drift-and-Fill Mining (Ormaque deposit)
- Sizing
  - Drift Profile of 5 m wide by 3 m high, no maximum length
  - +15% to -15% drift gradient
- External dilution of 13%
- Mining recovery of 98%
- Ore development included in reserves considered 100% mining recovery and no overbreak dilution
- Ore development below breakeven cut-off grade but higher than 4.0 g/t was included as Mineral Reserves material if development was mandatory.
- Metallurgical recovery of 95.6%

During the creation of the stope shapes, a cut-off grade of 3 g/t was used by the software in order to create a broader quantity of mineable inventory in order to support sensitivity studies and mine planning scenarios. Each of the stopes was assigned a fully diluted grade based on the interrogation of the block model and the dilution parameters. This diluted grade was compared to the global cut-off grade before being incorporated in or discarded from the mine plan.

There are circumstances when mineralized material below the stated breakeven cutoff was added to the production stream if supported by a positive secondary economical test. For example, when additional stopes with grades slightly below breakeven cutoff are identified between two high grade stopes, or at the extremities of the mining horizon and do not require additional development. This material may be deemed economical as most of the costs associated with it have already been spent (sunk costs). Ideally, this material would not displace the mining of material above the breakeven cutoff, and efforts are taken to stockpile and feed this lower-value material to the processing stream when there is spare processing capacity. The decision to include this material in the mining profile is carefully analysed and approved by senior staff and/or managers.

During the review of the mining schedule, stopes with grade lower than the cut-off were incorporated if they did not require additional development and were supported by a local positive economical study.

### 15.3 Mineral Reserve Estimate

Mineral Reserves for the Triangle, Ormaque and Parallel deposits were prepared by EGQ Technical Services staff. The Mineral Reserve estimate is summarized in Table 15-3 and has an effective date of September 30, 2024. All Mineral Reserves are classified as Proven or Probable in accordance with the *2019 CIM Estimation of Mineral Resources and Mineral Reserves Best Practices Guidelines*.

As a matter of clarification, the identified Mineral Reserves are included in the total Mineral Resources described in Section 1. Tonnes and grade are diluted and considering mining recovery.

**Table 15-3: Lamaque Complex Mineral Reserves as of September 30, 2024**

Deposits	Proven			Probable			Total P&P		
	Tonnes	Grade	Ounces	Tonnes	Grade	Ounces	Tonnes	Grade	Ounces
Triangle	1,356,672	5.70	248,815	1,681,984	6.58	355,953	3,038,656	6.19	604,768
Ormaque	3 257	7.76	813	2,661,130	7.22	617,791	2,664,387	7.22	618,603
Parallel	-	-	-	274,150	6.04	53,227	274,150	6.04	53,227
<b>Total</b>	<b>1,359,929</b>	<b>5.71</b>	<b>249,628</b>	<b>4,617,264</b>	<b>6.92</b>	<b>1,026,971</b>	<b>5,973,936</b>	<b>6.65</b>	<b>1,276,598</b>

During the 4<sup>th</sup> quarter of 2024, the Lamaque Complex produced 63,742 ounces of gold, out of which 16,757 ounces came from Ormaque deposit during the processing of the bulk sample in December as expressed in Table 15-4.

**Table 15-4: Lamaque Complex Mineral Gold Production during Q4 2024**

	Tonnes Processed	Head Grade	Ounces Produced
Triangle	220,270	6.91	46,985
Ormaque	36,358	14.93	16,757
Total Processed Sigma mill	256,628	8.05	63,742

## 15.4 Qualified Person Comment on Reserve Estimate

The Mineral Reserve estimates could be materially affected by risks associated with mining. These may include unexpected changes in continuity of mineralization, geotechnical aspects such as ground collapse, excessive unplanned dilution, or reduction in metallurgical recoveries at the Sigma mill. There are no other identified mining, metallurgical, infrastructure, permitting or other relevant factors that could materially affect the Mineral Reserve estimates.

## 16 Mining Methods

### 16.1 Introduction

In March 2018 Eldorado completed a prefeasibility study and issued a Technical Report for the Lamaque Project that disclosed inaugural reserves from the upper Triangle and Parallel deposits. Subsequent construction of the underground gold mine began in 2018 with commercial production declared in March 2019. The mine has been producing continuously since 2019 from the Triangle deposit (upper Triangle), and ongoing exploration diamond drilling has outlined an extension of the Triangle deposit at depth (lower Triangle) in addition to identifying the nearby Ormaque deposit. The following items are the deposits that currently make up the Lamaque Complex.

- Upper Triangle (zones C1 to C5)
- Lower Triangle (zones C6 to C10)
- Parallel
- Ormaque
- Plug No 4

The deposits and existing and planned mine development are shown in an isometric view in Figure 16-1. There are no Mineral Reserves in Plug No 4 at the moment.

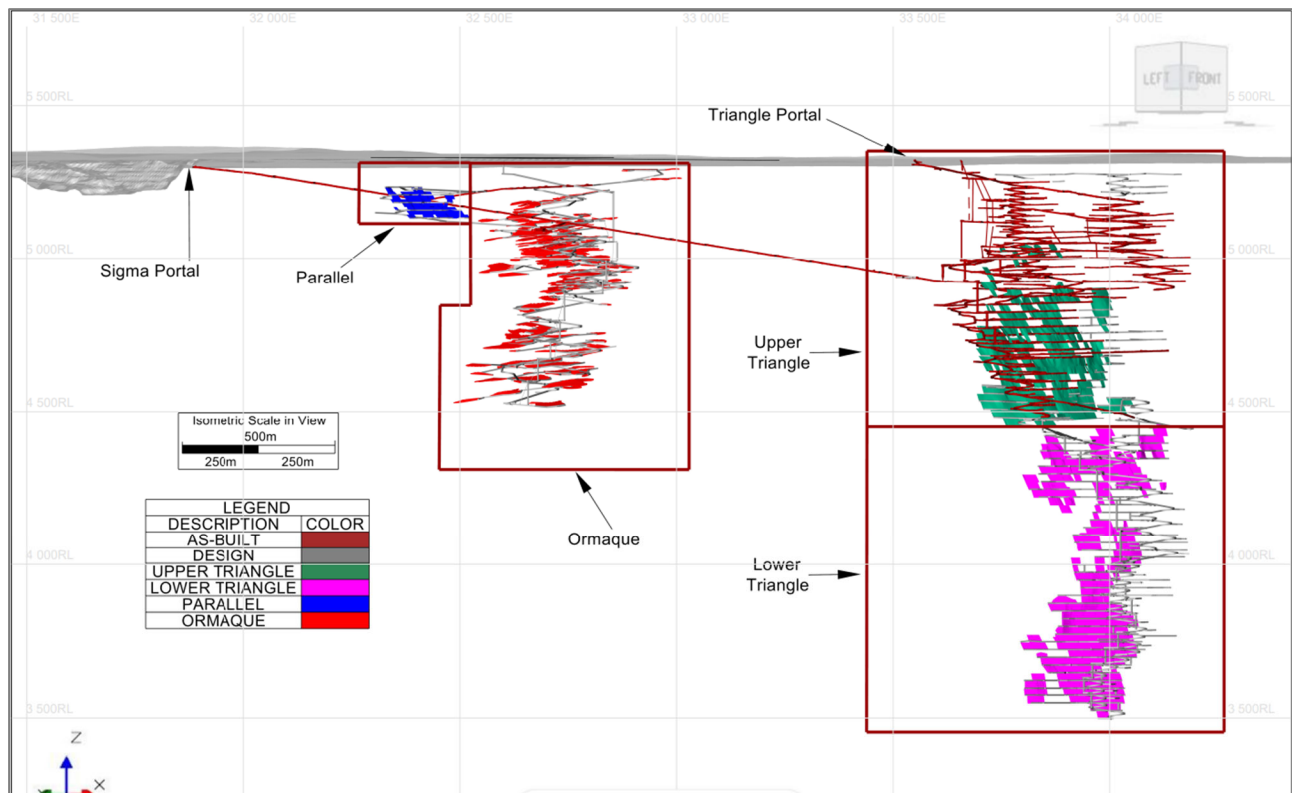

**Figure 16-1: Isometric View of the Lamaque Complex Deposits and Mine Planning Schematics (Eldorado 2024)**

There were two production cases prepared in this Technical Report to describe the current Mineral Reserves for the property (as of September 30, 2024 presented in Eldorado's press release dated December 11, 2024) and to demonstrate further potential of the Lamaque Complex when Measured, Indicated, and Inferred

Resource material from lower Triangle and Ormaque are added to the life of mine plan. The two cases are as follows.

- **Mineral Reserve:** The mine plan that supports the current Mineral Reserves and includes continued production from Measured and Indicated Mineral Resource material that has been converted to Proven and Probable Mineral Reserves from the upper and lower Triangle, Ormaque and Parallel deposits which is described in this section.
- **Inferred Mineralized Material:** A PEA for an extended mine plan that includes additional Measured, Indicated and Inferred Mineral Resources from the Triangle and Ormaque deposits, primarily at greater depth than the Reserves contemplated in this section. Mining and processing of mineralized material is fully described in Section 24 of this Technical Report and is separate from the Mineral Reserves described in this section.

## 16.2 Mineable Resource Summary

### 16.2.1 Mineral Resource Models

The resource models were prepared by Eldorado and have an effective date of September 30, 2024.

### 16.2.2 Mineralized Rock and Waste Rock Density

Mineralized rock and waste rock densities are included in the Mineral Resource model data. For calculations where data falls outside the resource model, the average in-situ densities summarized in Table 16-1 were used.

**Table 16-1: Mineralized and Waste Rock Average In-Situ Densities**

Item	Ormaque	Triangle / Parallel
In situ Mineralized Rock Density	2.71 t/m <sup>3</sup>	2.8 t/m <sup>3</sup>
In situ Waste Rock Density	2.71 t/m <sup>3</sup>	2.8 t/m <sup>3</sup>
Swell Factor	40%	40%

## 16.3 Mine Plan

### 16.3.1 Mine Design Parameters

The following parameters were considered during the mine design process.

- Health and safety for workers, communities, and the environment
- Company and regulating body standards and specifications (or industry best practices where standards and specifications are not available)
- Design concepts centred around a proactive approach to safety
- Prevention through design concepts
- Minimize risk to production and operating costs
- Operational flexibility
- Mining Method

#### 16.3.1.1 Current Mining Methodology

The primary mining method currently used in the Triangle deposits is mechanized longitudinal retreat longhole stoping. The existing mobile equipment fleet, mine infrastructure, services, and workforce skillsets are based on longhole. This method will continue to be used for upper Triangle, lower Triangle, and Parallel. Ormaque

will rely on the Drift and Fill mining method with paste fill provided from a new paste plant planned for construction.

The Triangle mine currently uses cemented rockfill (CRF) and unconsolidated rockfill as backfill. Starting in 2027, paste fill will be introduced with a reticulation system servicing lower Triangle, Ormaque, and Parallel. Mined material from all deposits will be hauled to surface using 45-tonne capacity diesel trucks and 50-tonne capacity battery electric vehicle (BEV) trucks. Ore is delivered to the Sigma mill ore pad via the Sigma-Triangle decline. Development waste rock is brought to surface via one of the two ramps, Sigma or Lamaque, where it is placed on the respective waste pads.

### **16.3.1.2 Longitudinal Longhole Stoping**

Longitudinal Longhole Stoping (LLS) is a common method used in underground mining due to the comparatively low cost and relatively high mechanized productivity. It is a safe mining method, with the use of remotely operated load haul dump (LHD) machines ensuring that workers are not exposed to unsupported ground. Ore is recovered in vertical or sub-vertical mining blocks referred to as stopes. The longitudinal approach is well suited for narrow veins, since the lengths of the stopes are not limited by the thickness of the mineralization. The stope cycle consists of drilling, blasting, mucking, and backfilling. Proper engineering must be completed to assure final wall stability.

Stopes typically have two accesses, the overcut and the undercut. The overcut is used for drilling, blasthole loading and backfilling, while the bottom undercut is used for mucking. Drilling is completed with vertical to subvertical blastholes rings. Vertical slot raises are developed using a Machine Roger V-30 boring head. The stope is typically blasted in several separate steps. A smaller opening blast is completed first and mucked out to create sufficient void (the slot) for the following production blasts. Production drill hole accuracy is essential to control external dilution and to optimize ore size distribution.

Production drifts are developed along strike in the ore to reduce waste development. Stopes are mined by retreating stope by stope from the end of the ore zone, or a pre-determined location, back to the access point. In this sequence, each stope is backfilled with CRF and allowed to cure before the adjacent stope is mined. Stope sequencing is completed bottom up.

A typical layout for LLS is shown in Figure 16-2.

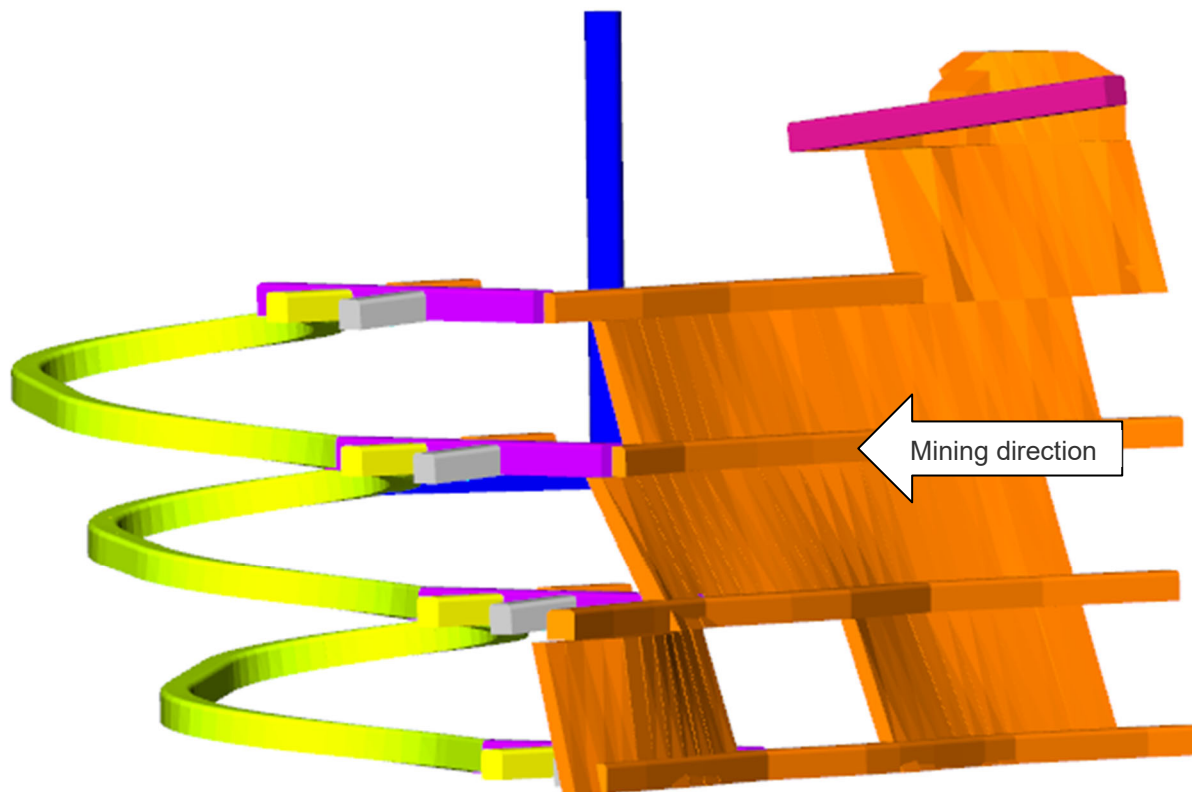

**Figure 16-2: Longitudinal Longhole Stoping** (typical example, Eldorado 2024)

Table 16-2 describes the Longitudinal Longhole Stoping design criteria.

**Table 16-2: Mine Design Criteria: Longitudinal Longhole Stoping**

Description	Criteria
Stope Height (sublevels floor to floor)	25 m vertical
Stope Length (along strike)	25 m maximum
Stope Width (thickness)	2.0 m (min) – 9.0 m (max)
Stope Inclination	-90° (vertical) – -45° (min)
Backfill Type	Cemented Rockfill Unconsolidated Rockfill Paste fill

### 16.3.1.3 Primary-Secondary (Transverse) Longhole Stoping

Primary-secondary longhole stoping (PSLS) has the same mining cycle and benefits as Longitudinal Longhole Stoping. Transverse refers to the orientation of the stopes in relation to the geometry of the mineralization and is better suited for areas with greater thickness. PSLS stopes and stope access drifts are oriented perpendicular to the strike of the mineralization. Where the mineralization width is greater than 9 m over several stopes, the PSLS method is preferred. The sublevel spacing is the same as longitudinal longhole. Yellow stopes in Figure 16-3 illustrates a typical PSLS level layout.

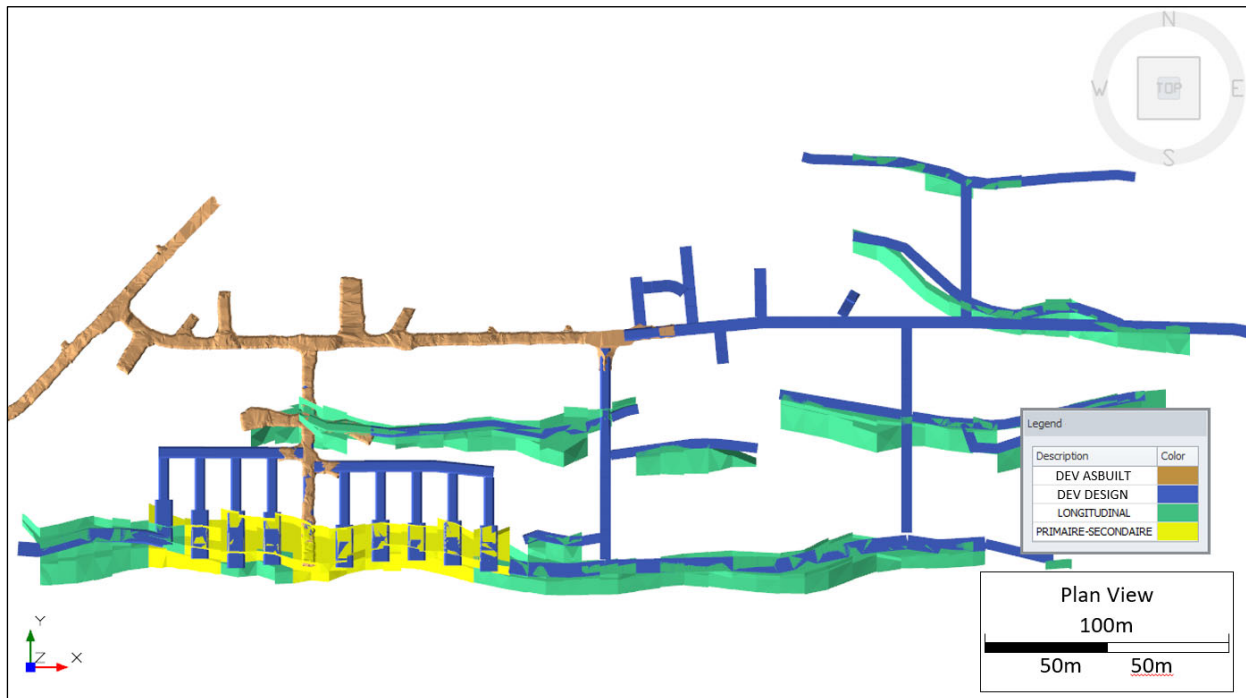

**Figure 16-3: Sublevel plan view example of a PSLS (Eldorado 2024)**

Within a single transverse stope, mining starts at the far boundary of the stope and retreats to the access. Regional stope sequencing is planned as primaries and secondaries and mined from the bottom in an upward direction. All primaries are backfilled with cemented backfill, currently CRF. Secondaries typically do not require cemented backfill unless the transverse stope is mined in more than one panel. In these scenarios, secondaries are initially backfilled with CRF until the CRF reaches the top sill level (i.e., stope edge) to create a consolidated fill end wall. The remainder of the void is backfilled with waste rock. If paste fill is being used, lower cement content is used when backfilling secondary transverse stopes.

In PSLS, a main sublevel drift is developed in waste at a standoff distance of the mineralization. It is designed following geotechnical considerations.

A typical layout for PSLS is shown in Figure 16-4, criteria used are shown in Table 16-3.

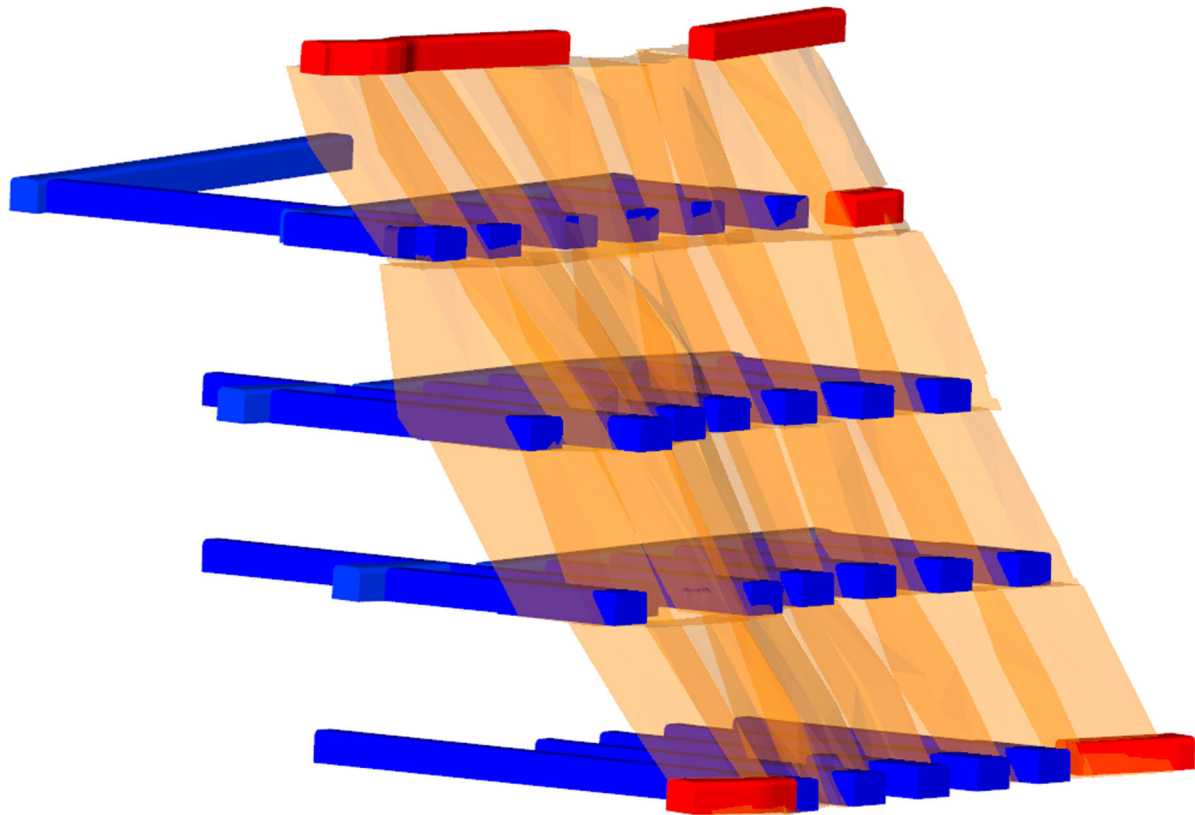

Figure 16-4: Primary-Secondary Transverse Longhole Stopping, (typical example, Eldorado 2024)

Table 16-3: Mine Design Criteria: Transverse Longhole Stopping

Description	Criteria
Stope Height (sublevels floor to floor)	25 m vertical
Stope Length (thickness)	> 9 m
Stope Width (along strike)	15.0 m
Sequencing	Primary / Secondary
Backfill Type	Cemented Rockfill Unconsolidated Rockfill Paste fill

### 16.3.1.4 Uppers Longhole Stopping

In areas where stopes do not extend up to the next upper-level access with regular spacing of 25 m, they may be mined as back stopes (i.e., “uppers” stopes). Refer to Figure 16-5 for an illustration of Uppers Longhole Stopes. Uppers longhole stopes have the same general mining cycle but are drilled, loaded, blasted, and mucked from the bottom sill. With only bottom access, and no top access to deliver backfill material, these stopes are typically not backfilled. Uppers stopes are typically located at the extremities of the mining area where a lack of backfill does not create geotechnical hazards for adjacent areas in the mine.

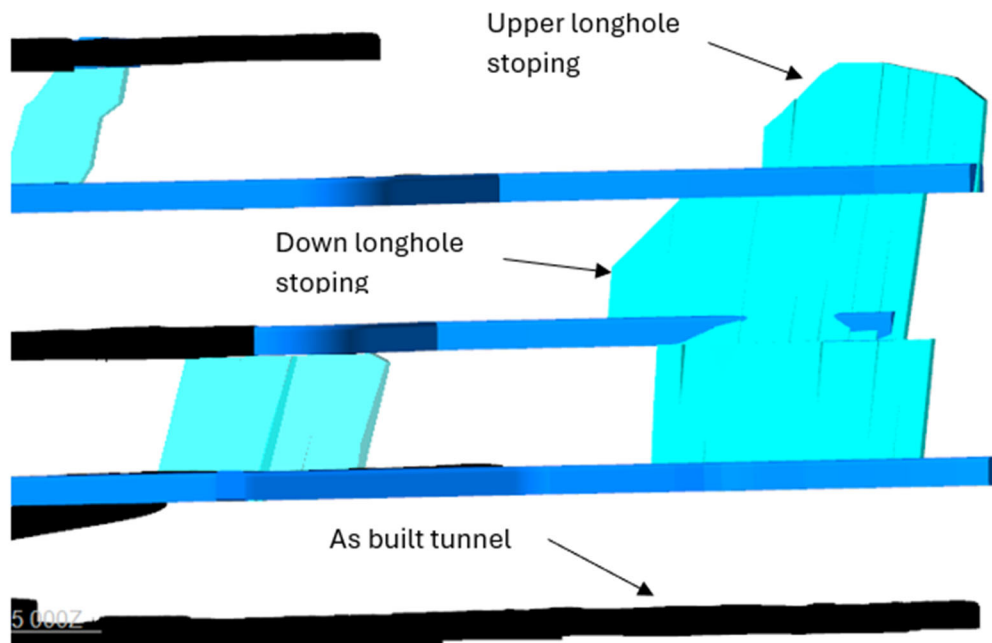

**Figure 16-5: Illustration of Uppers Longhole Stopping** (typical example, Eldorado 2024)

Uppers stopes use similar design criteria as LLS. Refer to Table 16-4 for uppers longhole stopping design criteria.

**Table 16-4: Mine Design Criteria: Uppers Longhole Stopping**

Description	Criteria
Stope Height	12-15 m
Stope Length	25 m
Stope Width	2.0 m (min) – 9.0 m (max)
Stope Inclination	-90° (vertical) – -45° (min)
Backfill Type	Not Backfilled

### 16.3.1.5 Sill Pillar Longhole Stopping

Creating multiple stoping mining centers allows higher production profiles and allows more mining flexibility in scheduling. For example, in Figure 16-6, when Mining Block 2 mines up under Mining Block 1, a sill pillar is created. Recovering ore from the sill pillar requires developing new top cuts adjacent to the previously blasted and backfilled workings, usually in the hanging wall. Previously, redeveloped top cuts in backfilled areas were in use, but such development was too consuming in term of time and costs and the method was discarded. The sill pillar is then mined as transverse or longitudinal longhole stopes depending on the mineralization thickness. These stopes are referred to as Sill Pillar Stopes.

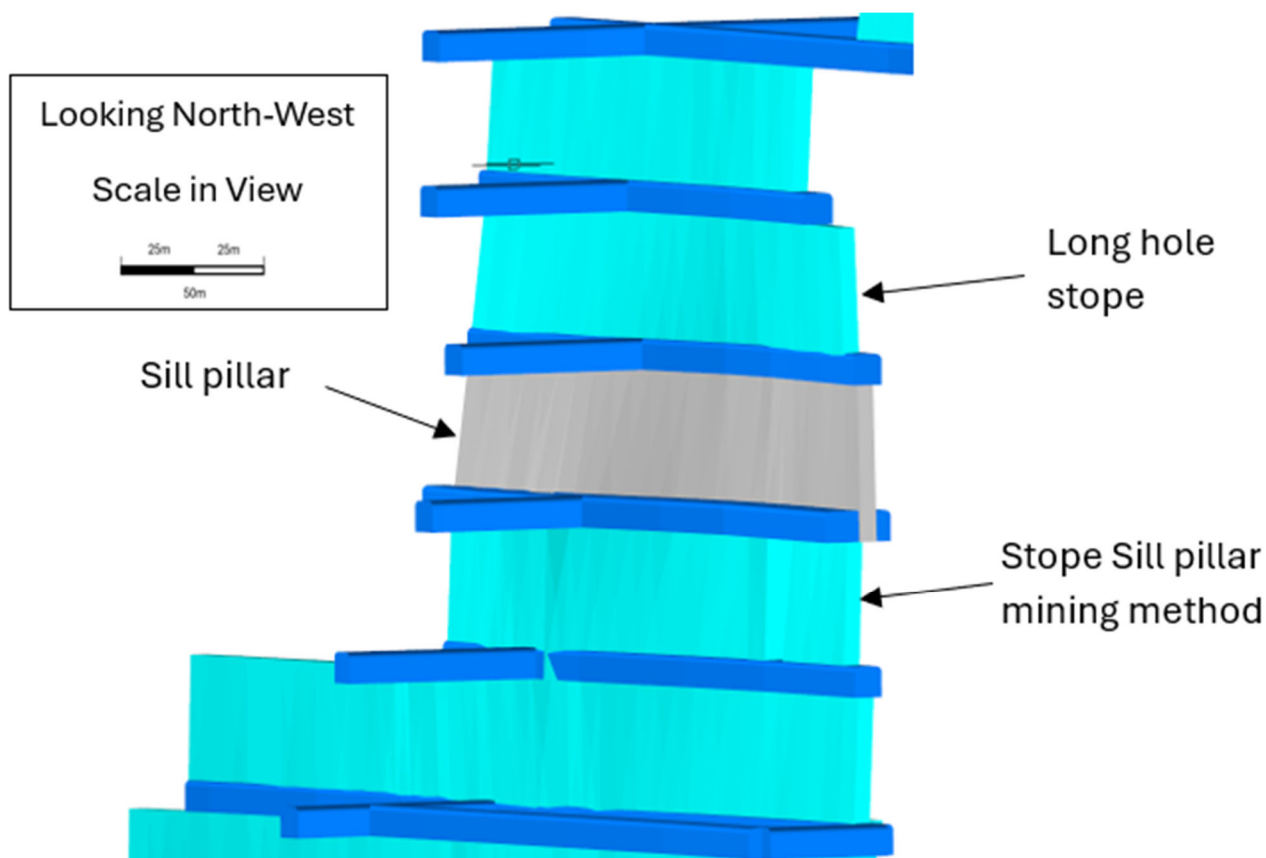

**Figure 16-6: Illustration of a Sill Pillar** (typical example, Eldorado 2024)

Sill Pillar stopes maintain the same design criteria as LLS. Refer to Table 16-5 for Uppers Longhole Stopping design criteria.

**Table 16-5: Mine Design Criteria: Sill Pillar Longhole Stopping**

Description	Criteria
Stope Height (sublevels floor to floor)	25 m
Stope Length	25 m
Stope Width	2.0 m (min) – 9.0 m (max)
Stope Inclination	-90° (vertical) – -45° (min)
Backfill Type	Cemented Rockfill Unconsolidated Rockfill Paste fill

### 16.3.1.6 Drift and Fill

Drift and fill (DAF) mining extracts ore in horizontal slices (cuts) using conventional development methods when the ore zone is thin, and dip is flat. Mining is completed by extracting slices (drifts) one beside the other or in primary-secondary fashion. DAF mining is a selective mining method that allows near complete recovery of mineralization. Smaller face rounds with good drilling and blasting control minimizes unplanned dilution from waste or adjacent backfill. Ore zone characteristics, mining equipment capabilities (limited drift height), and ground conditions, are critical factors for slice design.

The mining sequence of independent lenses can either be bottom up (overhand) or top down (underhand), rock mechanics being a sequence design element. Geological mapping completed on every round allows precise adjustment to enhance ore extraction and reduce dilution. In short term planning, DAF mining can optimize orebody recovery by redesigning defined stope boundaries to chase stringers of high grade mineralization not previously identified in the Mineral Resource model.

The development for DAF mining includes a ramp in the waste rock, with attack accesses to the mineralization, as seen in Figure 16-7.

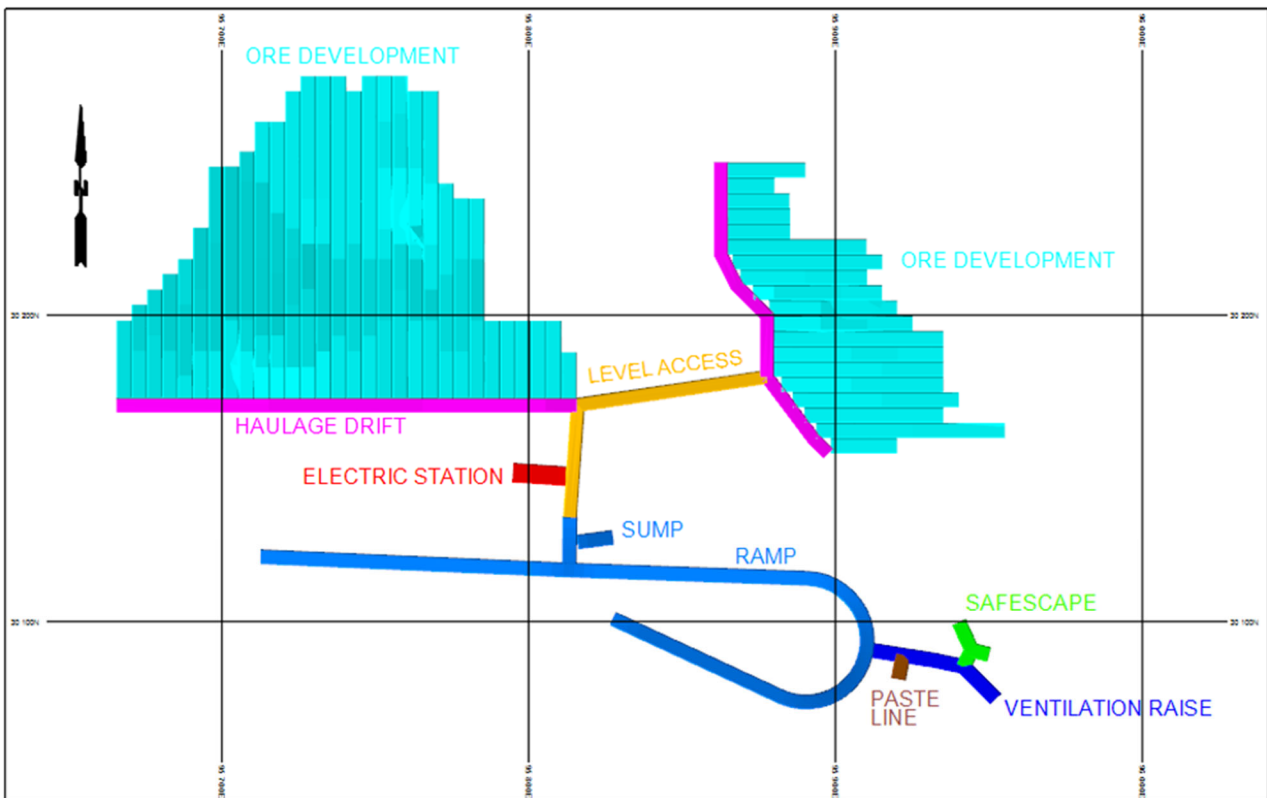

**Figure 16-7: Typical DAF Mining Level (Eldorado 2024)**

The Ormaque mineralised system consists of multiples of undulating sub-horizontal veins with variable thickness up to 8 m that thin out on the edges. The flat dipping geometry and variable thickness of the veins was the main criteria for selecting the DAF method for Ormaque. Drift height and width are based on deposit geometry, equipment limitations (low drift height), and geotechnical requirements (bolt lengths). Drift dimensions are a minimum of 3.0 m to a maximum of 8.0 m high, and 5.0 m wide. Each mineralized lens is accessed from an optimized level access drift from the main ramp. A main drift is developed along the inside edge of the mineralized contact. From this main drift, perpendicular crosscuts will be driven to the outer boundary of the lens. Ore crosscuts to be mined out in a primary-secondary fashion. Once mined to full length and height, the openings will be backfilled. Depending on the lens size, geometry, and relative location to other lenses, shotcrete post-pillars may be used in primary crosscuts prior to paste filling. When lenses are greater than 6 m high, the initial drift will be mined at the top of the lens, followed by floor benching. Final drift maximum height will be up to 8 m when completed.

Table 16-6 summarizes the mine design criteria for Drift and Fill for the Ormaque deposit.

**Table 16-6: Drift-and-Fill Mining Criteria**

Item	Criteria
DAF Cut Height	3.0 m (min) / 8 m (max)
DAF Cut Width	5.0 m
DAF Stope Gradient	0% up to +/- 15%
Backfill	Paste fill and shotcrete post pillar when required
Sequence	Primary / Secondary, bottom-up

## 16.3.2 Dilution and Mining Recovery

### 16.3.2.1 Internal Dilution

Internal dilution refers to the low-grade mineralized material and/or waste rock that is included within the stopes and development shapes that is mined along with the mineralized resource. The mine design and scheduling software accounts for the tonnes and grade for internal dilution contained in the mining shapes in the reported production tonnes.

### 16.3.2.2 External Dilution

External dilution refers to the surrounding mineralized material, waste rock or backfill that is recovered with the stope resource due to overbreak during mining. The estimated external dilution for each type of method has been included in the mine plan and is summarized in Table 16-7.

**Table 16-7: External Dilution Factors**

Type	External Dilution
Mineralized Development	No overbreak
Drift and Fill	13%
Longhole	25%

### 16.3.2.3 Mining Recovery

The mining recovery factor refers to the actual mineralized resource that will be removed from the shape. The mining recovery factors by mining method are summarized in Table 16-8.

**Table 16-8: Mining Recovery Factors**

Type	Mining Recovery Factor
Stope Development	100%
Longhole Mining	95%
Drift and Fill Mining	98%

## 16.4 Underground Mine Design

### 16.4.1 Mine Access

#### 16.4.1.1 Triangle Ramp

Two ramps service the Lamaque Complex: The Triangle ramp and the Sigma-Triangle decline. Access to the Triangle deposit is via the existing Triangle ramp from surface (highlighted in red) in Figure 16-1. The Triangle mine surface operation is shown in Figure 16-8 with the ramp (adit) circled in red.



Figure 16-8: Plan View - Triangle Ramp Portal Location (Source: Google Earth, 2024 image)

#### 16.4.1.2 Sigma-Triangle Decline

The primary haulage route to the Sigma mill and access to Ormaque and Parallel will be via the 2.4 km long Sigma-Triangle decline, which was completed in 2021. The decline is 8.0 m wide by 5.5 m high at an average gradient of 14%. The Sigma-Triangle decline provides access to surface via the portal located in the inactive Sigma open pit, illustrated in Figure 16-9.



Figure 16-9 Sigma-Triangle Decline Portal Location (Source: Google Earth, 2024 image)

## 16.4.2 Mine Development

### 16.4.2.1 Lateral Development

Ramps are designed at  $\pm 15\%$  gradient with levelling off at access points. Level development is designed at a 2% gradient to allow adequate water drainage, along a ditch on the floor, to sumps for dewatering in Triangle and up to 15% in Ormaque to comply with lenses geometry. Remuck bays are spaced approximately every 120 meters. The design criteria for lateral development are presented in Table 16-9.

Table 16-9: Lateral Development Criteria

Heading Type	Heading Profile Triangle	Heading Profile Ormaque
Internal Ramp	5.1 m W x 5.5 m H	4.9 m W x 5.0 m H
Level Access Cross Cut Footwall Drive / Level Haulage Remuck Exploration Drift CRF Mixing Bay Paste Transfer Bay Refuge Station Ventilation Raise Access	5.0 m W x 5.0 m H	4.6 m W x 4.1 m H
Shop	9.0 m W x 5.5 m H	
Material Storage	9.8 m W x 5.0 m H	9.0 m W x 6.0 m H

Heading Type	Heading Profile Triangle	Heading Profile Ormaque
Sump	4.5 m W x 5.0 m H	4.9 m W x 5.0 m H
Electrical Substation	5.0 m W x 4.5 m H	5.0 m W x 5.0 m H
Emergency Escapeway Access	6.5 m W x 4.5 m H	4.6 m W x 4.1 m H
Stope Development – Longhole Mining Method	4.2 m W x 4.2 m H	Not Applicable
Stope Development – Drift and Fill Mining Method	5.0 m W x 2.5 to 8.0 m H	5.0 m W x 3.0 to 8.0 m H

### 16.4.2.2 Vertical Development

The design criteria for vertical development are summarized in Table 16-10.

**Table 16-10: Vertical Development Criteria**

Heading Type	Heading Profile Triangle	Heading Profile Ormaque
Ventilation Raise without Escapeway	Circular: 4.27 m dia.	Circular: 5.1 m dia.
		Circular: 4.6 m dia.
Ventilation Raise with Escapeway	Circular: 3.50 m dia.	Not Applicable
	Circular: 4.27 m dia.	
	Circular: 4.88 m dia.	
	Circular: 7.32 m dia.	
Escapeway without ventilation	Circular: 1.07 m dia.	Circular: 1.07 m dia.

### 16.4.2.3 Overbreak and Design Allowance

Overbreak and design allowance factors applied to the neat quantities for lateral development in waste rock (but not mineralized development quantities) are summarized in Table 16-11. These factors have been applied in the design and scheduling software. Allowances account for miscellaneous excavations that are expected but not included in the design model, including safety bays, slashes at intersections, back slashes, local width or height variations, etc. For the Ormaque deposit, additional excavations that are not included in the design model include remuck bays, sumps, and secondary electrical cut outs.

**Table 16-11: Overbreak and Design Allowances**

Item	Value
Overbreak in all Lateral Waste Development	10%
Design Allowance on Lateral Waste Development	10%
Design Allowance on Lateral Waste Development - Ormaque Only	15%

### 16.4.2.4 Development Quantities

The development quantities for Case 1 (Triangle, Ormaque, and Parallel, Measured and Indicated Mineral Resources) are presented in Table 16-12. Drift and fill ore drifts were included as production stopes and excluded from total development numbers. Only haulage drifts and level access drifts were included in the total.

**Table 16-12: Development Quantities for Case 1**

Development Type	Total
Lateral CAPEX (km)	21.9
Vertical CAPEX (km)	1.2
Lateral OPEX (km)	26.5
<b>Totals</b>	
Development (km)	49.6
Development (Mt)	3.4

The development quantities for Case 2 (addition of Triangle and Ormaque Inferred Mineral Resources) are presented in Table 16-13.

**Table 16-13: Development Quantities for Case 2**

Development Type	Total
Lateral CAPEX (km)	53.3
Vertical CAPEX (km)	2.8
Lateral OPEX (km)	55.4
<b>Totals</b>	
Development (km)	111.5
Development (Mt)	8.3

## 16.4.2.5 Mine Development Layout

### 16.4.2.5.1 Upper Triangle, Lower Triangle, Parallel

Upper Triangle, lower Triangle, and Parallel will be accessed via ramps. The ramps and raises between each sublevel create the ventilation circuit and provide secondary egress. Sublevels are spaced at 25 m, and each level has a minimum of one ramp access. Figure 16-10 shows the existing development and mine ramps in black.

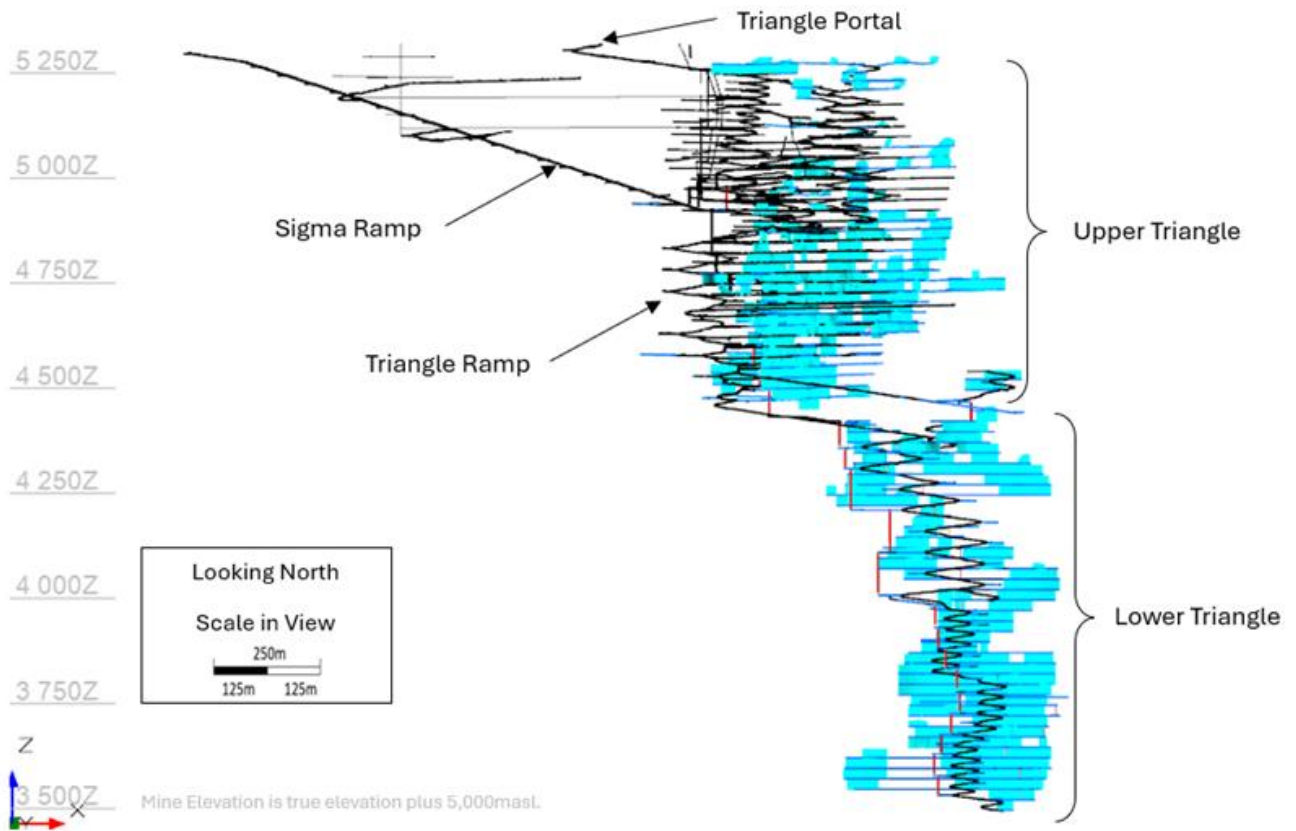

**Figure 16-10: Mine Design with Ramps and Existing Development in Black (Eldorado 2024)**

Upper Triangle and lower Triangle are separated into different mining zones, from C1 to C10. Zones C1 to C5 are considered upper Triangle and zones C6 to C10 are lower Triangle. Figure 16-10 shows the zones for Triangle. Figure 16-11 shows all the mining zones for the Lamaque Complex.

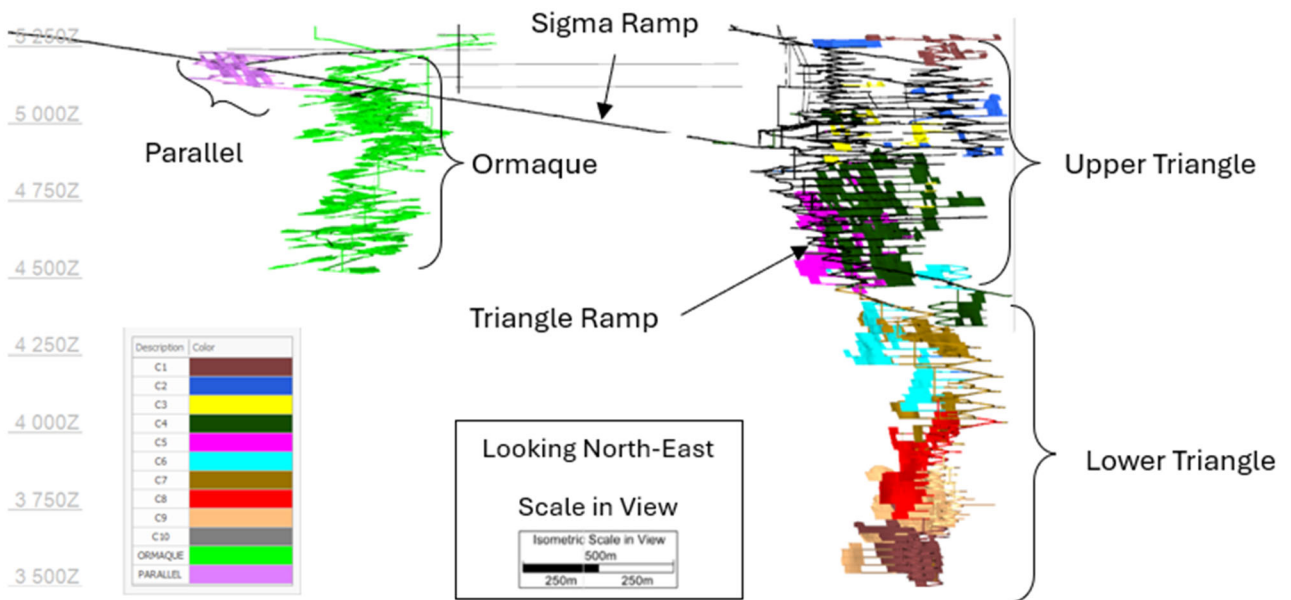

**Figure 16-11: Mining Zones, Looking North-East (Eldorado 2024)**

Each mining sublevel uses a typical layout consisting of a level access, central haulage drift, and mineralized development drives to access stopes. Level development also includes ventilation access and raises, remuck bays, electrical bays, and other development for infrastructure. Figure 16-12 shows a typical Triangle mine sublevel layout.

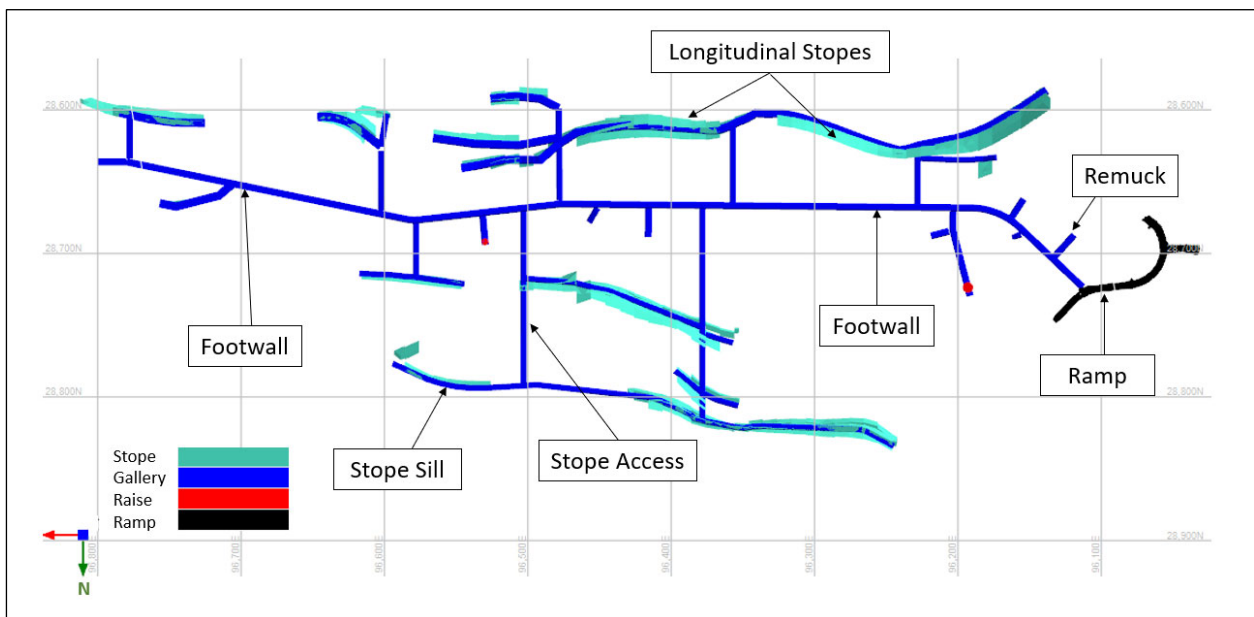

**Figure 16-12: Typical Triangle Sublevel Layout (Eldorado 2024)**

### 16.4.2.5.2 Ormaque

Ormaque will be accessed via ramps located south of the deposit, as shown on Figure 16-13. The ramps and raises between each level create the ventilation circuit and provide secondary egress. Level development also includes remuck bays, electrical bays, and other development for infrastructure (as displayed below, in Figure 16-13). The spacing between levels is based on lens location because they are flat-lying and formed in vertically stacked clusters. Each lens may require its own level. There are no related activities on upper or lower levels in the DAF mining cycle.

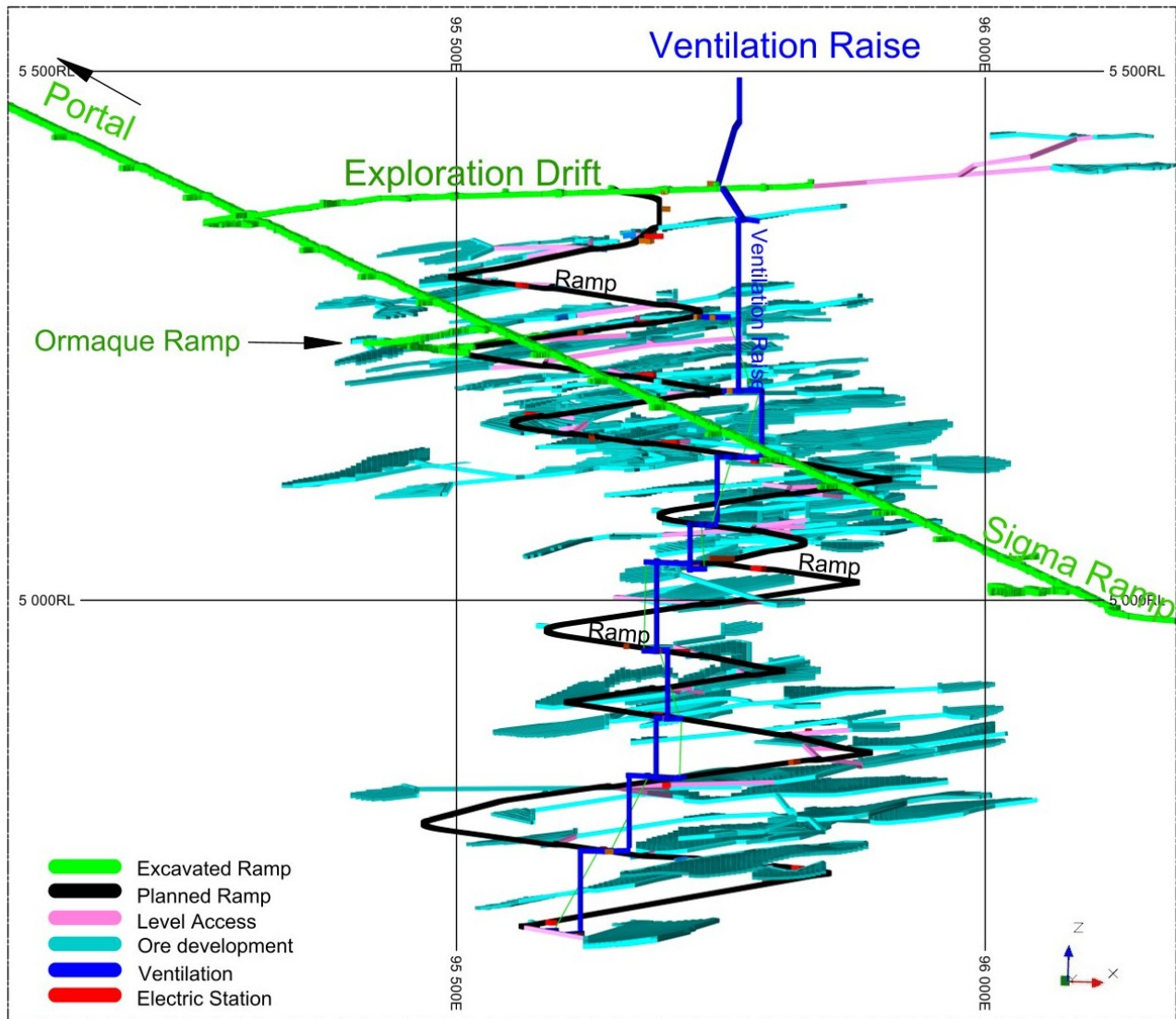

Figure 16-13: Ormaque MI&I Design Longitudinal View Looking East (Eldorado 2024)

## 16.5 Mine Backfill

Mine backfilling is an integral part of the mining cycle at Triangle and is needed to provide long term regional ground stability, as well as providing a working floor for ongoing mining operations. Longhole stope volumes range from about 300 m<sup>3</sup> to 8,000 m<sup>3</sup>. Currently, empty stopes are filled using varying combinations of

cemented rockfill and unconsolidated rockfill. If geomechanical context and operational constraints allow, unconsolidated rockfill is preferred as it is more productive and less expensive.

The existing backfill system comprises a series of 6 m<sup>3</sup> underground mixing pits filled with run-of-mine waste and mixed with a cement slurry batched on surface and delivered underground via 50 mm slicklines. The current mixing system produces about 90 m<sup>3</sup> of CRF per shift. After batching, the material is trammed and dumped into the longhole stopes with LHDs.

Depending on the situation, when cemented rockfill is required, a low strength mix with 3.5% binder may be preferred instead of a high strength mix with 6% binder.

In the long term, the mine will change to paste fill utilizing pressure filtered tailings (approximately 40%) from the Sigma mill. The paste plant consists of a conventional flowsheet with a filter press, cake feed hopper, feed conveyor, paste mixer, cement delivery system via a rotary valve and screw conveyor, vortex mixer and finally discharge to a paste pump.

The paste plant will be located near the regional office on highway 117. It is designed at 750 m<sup>3</sup>/day and will provide a paste mix at a designed 71.0% solids for a nominal yield stress of about 150 kPa for Ormaque. Mining at Triangle will require a higher strength of 300 kPa. The paste will be sent down to Ormaque in a dedicated cased borehole located below the paste plant. It will then be delivered to stopes using carbon steel schedule 80 x 100mm pipes. Delivery to Triangle mine from Ormaque will use the Sigma-Triangle decline down to Triangle. In the decline, NB100mm piping will be used with a flow velocity of about 1.5 m/s. A paste pump rated at 45 m<sup>3</sup>/hr for a 120 MPa discharge pressure will be required at the paste plant to overcome the accumulated friction losses down the Sigma-Triangle decline.

The paste reticulation backbone shown in Figure 16-14 consists of Schedule 80 carbon steel piping, switching to Schedule 40 on the working mine levels. The final 200 m of the run into the stopes being filled will consist of SDR 9 HDPE piping.

Once the paste plant is operational, cemented paste utilizing mine tailings will be used as the primary lower Triangle backfill option, whereas the RF/CRF backfill will be used where paste reticulation can't be delivered. Waste rock not used for backfill will be trucked to surface for construction activities associated with TSF construction or disposal. The use of paste with mine tailings will reduce the need for storage of tailings on surface, hence lowering tailings dam construction costs and TSF operating costs.

Based on laboratory test work, the following three paste mixes have been proposed:

- A low strength bulk paste for filling of longhole stopes. This paste has a nominal binder content of about 2% and a targeted strength of 200 kPa.
- A medium strength paste for sill pours up to 5 m wide. This paste will have a nominal binder content of 4%.
- A high strength mix for sill pours up to 10 m wide. This paste will have a nominal binder content of 6%.

Laboratory testing has shown exceptional strengths using a locally available slag cement binder.

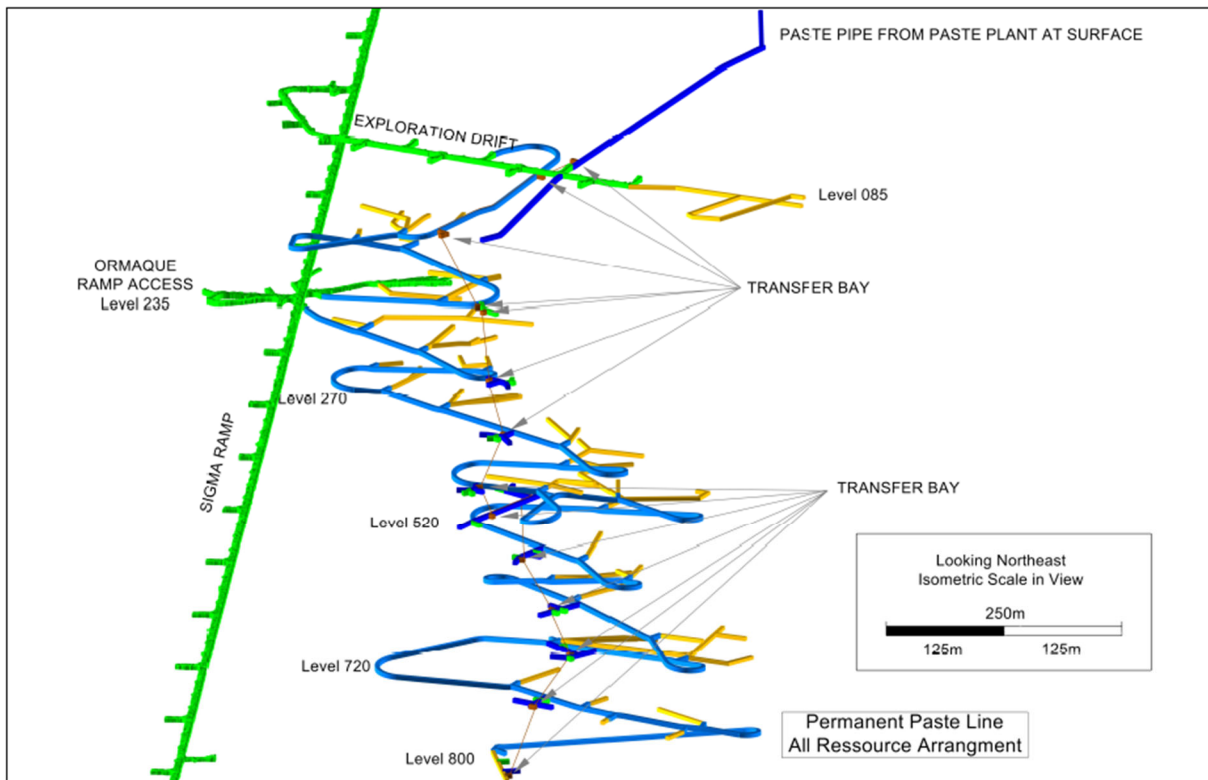

Figure 16-14: Ormaque Paste Reticulation Network (Eldorado 2024)

## 16.6 Productivity Rates

### 16.6.1 Effective Hours

The estimated available productive time for underground activities during a typical 11-hour shift is summarized in Table 16-14.

Table 16-14: Effective Work Hours per Shift

Description	Hours / Shift
Shift Length	11.0
Safety Meeting / Line up	0.5
Travel Time In	0.5
Supervisor Visit	0.5
Lunch	0.5
Travel Time Out	0.5
Total Time	8.5
Effective Minutes per Hour	55
Effective Shift Hours	7.8
Effective Daily Hours	15.6

## 16.6.2 Labour

The underground labour consists of contractors for major construction projects and Eldorado personnel for underground development, operations, sustaining capital, and miscellaneous underground construction projects.

## 16.6.3 Development

Development rates are based on demonstrated performance experienced at the Triangle mine. The rates reflect the advance that each jumbo and associated gear will achieve over extended periods of operation. Table 16-15 presents the development advance rates for each heading type.

**Table 16-15: Development Advance Rates**

Activity Type	Advance Rate
<b>Vertical Development</b>	
Raise with Escapeway (Platform)	0.82 - 1 m/day
Raise with no Escapeway (Conventional)	90 m/month
<b>Lateral Development</b>	
Internal Ramp	120 m/month
Level Access Cross Cut Footwall Drive / Level Haulage Remuck Exploration Drift Mixing / Paste Transfer Bay Refuge Station Ventilation Raise Access Shop Sump Electrical Substation Emergency Escapeway Access Mineralized Gallery	60 m/month
Material Storage Bays	30 m/month

## 16.6.4 Production

The mining production rate for the Lamaque Project is based on the operating mining rates, permitting restrictions, and the Sigma mill processing throughput of 2,500 tonnes per day (tpd). The hoisting permit for Triangle allows for 2,650 tpd and for Parallel and Ormaque another 2,500 tpd. As Ormaque will be mined using DAF, it is planned in a range of 1,000 to 1,300 tpd, based on detailed build-ups of mine schedules using Deswik software.

Production rates for Longhole mining are based on historic performance of Triangle (Table 16-16).

**Table 16-16: Longhole Mining Mucking Rates**

Mining Zone	Mucking Rate	Effective Mucking Time per Day
Upper Triangle: zones C1 to C5	1,200 tonnes / day	13 hours / day

### 16.6.4.1 Drift and Fill

The targeted tonnage rate for the Ormaque deposit is 1,000 tpd of ore, with allowable rates up to 1,300 tpd when needed after consolidating production schedules with Triangle. Mining zones will be designed by grouping lenses together to assure overall geotechnical stability, and each lens will be sub-divided into blocks to optimize productivity. Sequencing using a primary / secondary approach was selected for DAF at Ormaque. The production and backfilling activities are assumed to alternate every second mining block allowing adequate mining and backfill curing time (refer to Figure 16-15). The paste fill rate is estimated for the blocks using calculated volumes and placement rates. To reach the targeted production rates, two to three mining blocks will be mined concurrently.

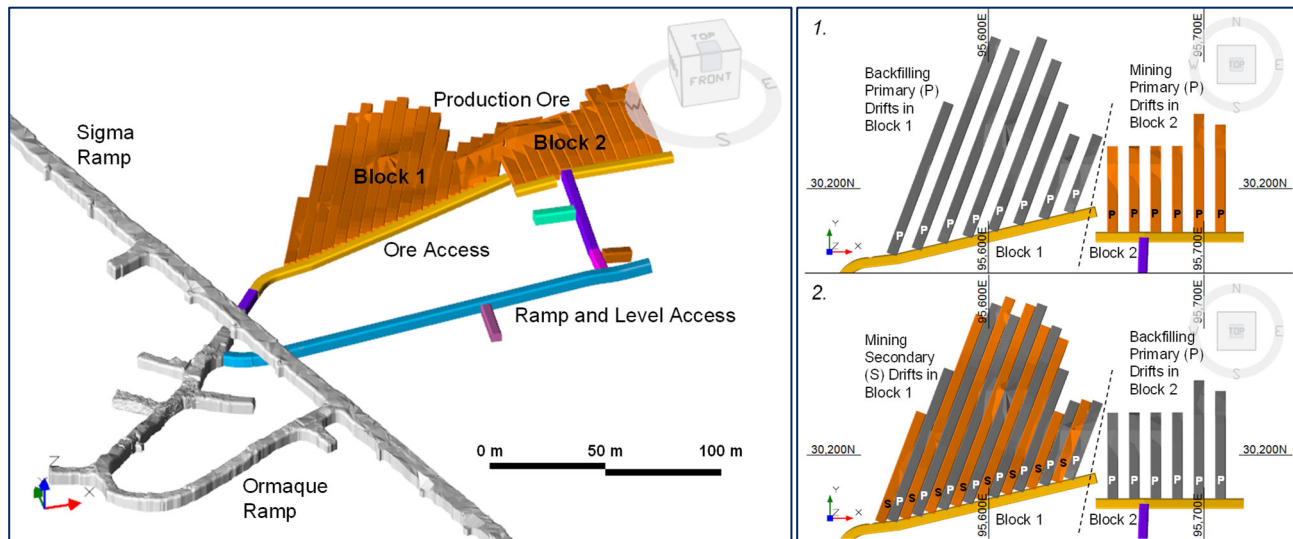

Figure 16-15: Conceptual Primary-Secondary Mining Sequence of Blocks (Eldorado 2024)

## 16.7 Mine Development and Production Schedule

All mine development and production scheduling has been completed using Deswik scheduling software. The schedule is interactively linked to the 3D mine model. All development and production scheduling has been based on dependency linking and start date constraints within the mine model. All data is contained within the mine model and schedule.

The mine plan that supports the current Mineral Reserves is summarized in Table 16-17.

Table 16-17: Annual Summary of Waste and Mineralized Tonnes

Mined Material	Total	2025	2026	2027	2028	2029	2030	2031	2032
Waste (kt)	2,938	959	679	770	242	81	79	76	52
Mineralized (kt)	5,672	879	907	923	920	584	518	516	424

Note: Recovered and Diluted Tonnes, rounded

### 16.7.1 Development Schedule

The Case 1 development schedule consists of ongoing development to support the Triangle mine plan, with additional capital development to bring Ormaque and Parallel into production as outlined in Table 16-18. The LOM development schedule for Case 1 is summarized in deposit in Figure 16-16 and by cost center in Figure 16-17.

**Table 16-18: Life of Mine Development Schedule**

Development Type	Total	2025	2026	2027	2028	2029	2030	2031	2032
Lateral CAPEX (km)	21.9	8.3	6.0	5.0	2.0	0.2	0.1	0.2	0.1
Vertical CAPEX (km)	1.2	0.4	0.3	0.4	0.0	0.0	0.0	0.0	0.0
Lateral OPEX (km)	26.5	6.3	4.4	6.4	2.4	1.7	1.8	1.9	1.7
<b>Totals</b>									
Development (km)	49.6	15.0	10.7	11.8	4.4	1.9	2.0	2.1	1.7
Development (kt)	3417	1138	744	865	290	103	98	103	77

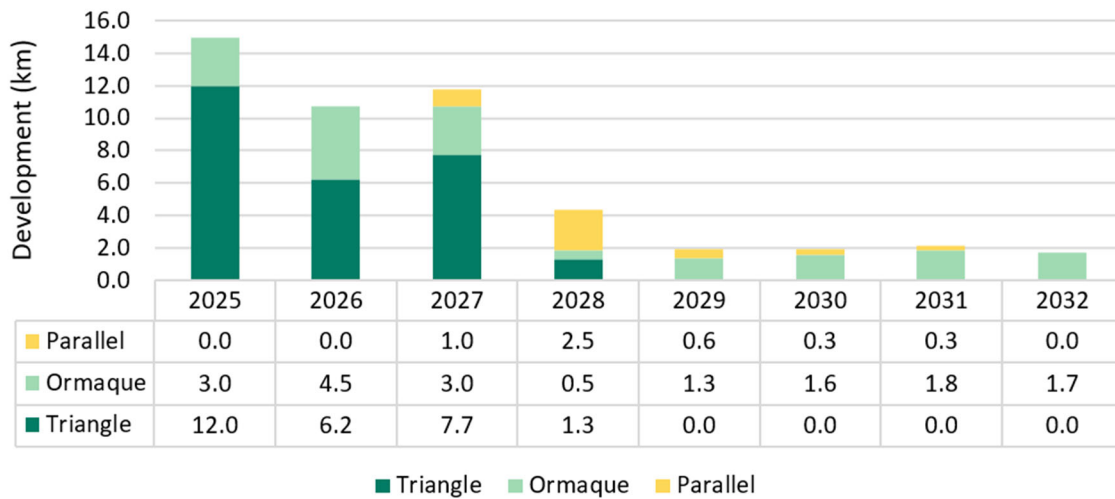

**Figure 16-16: Total Annual Development Metres by Deposit (Eldorado 2024)**

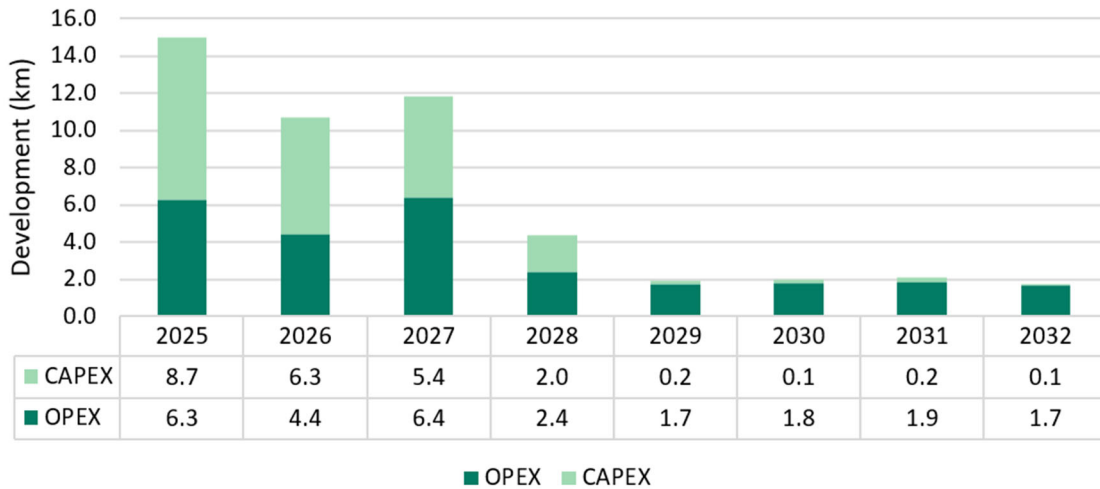

Figure 16-17: Total Annual Development Metres by Cost Centre (Eldorado 2024)

## 16.7.2 Mine Production Schedule

The annual mine production tonnage profile for Case 1 is summarized by deposit in Table 16-19 and Figure 16-18.

Table 16-19: Mine Production Schedule

	Description	Total	2025	2026	2027	2028	2029	2030	2031	2032
Triangle	Mineralized Material (kt)	2,769.2	853.7	802.5	607.3	505.7	-	-	-	-
	Au Grade (g/t)	6.14	6.19	6.01	6.14	6.28	-	-	-	-
	Au Ounces (k Oz)	547.0	169.9	155.1	120.0	102.1	-	-	-	-
Ormaque	Mineralized Material (kt)	2,629.0	25.2	104.8	315.9	359.3	469.0	457.0	473.7	424.1
	Au Grade (g/t)	7.18	9.94	7.00	6.43	6.41	6.68	7.67	7.34	8.03
	Au Ounces (k Oz)	607.5	5.7	21.7	71.4	74.0	100.8	112.7	111.8	109.5
Parallel	Mineralized Material (kt)	274.2	-	-	-	55.4	114.8	61.4	42.5	-
	Au Grade (g/t)	6.04	-	-	-	5.79	6.29	5.85	5.94	-
	Au Ounces (k Oz)	53.2	-	-	-	10.3	23.2	11.5	8.1	-
Total	Mineralized Material (kt)	5,672.4	879.0	907.3	923.2	920.4	538.8	518.4	516.2	424.1
	Au Grade (g/t)	6.62	6.21	6.06	6.45	6.30	6.61	7.45	7.23	8.03
	Au Ounces (k Oz)	1,207.8	175.6	176.7	191.3	186.5	124.0	124.2	119.9	109.5

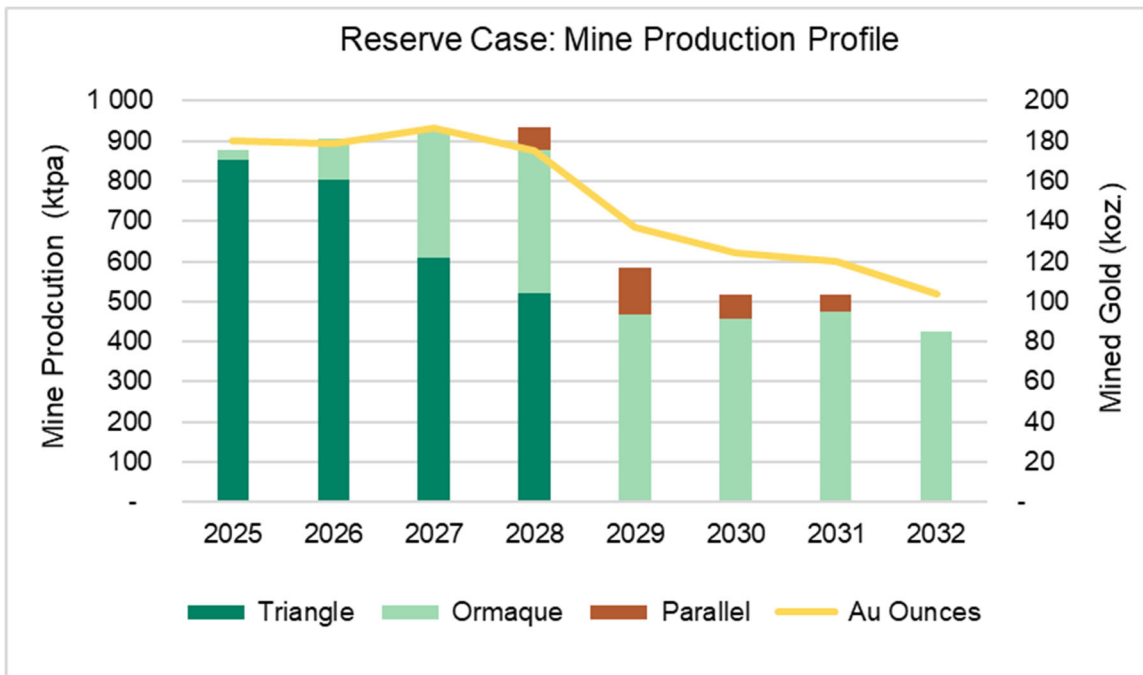

Tonnes are diluted and recovered

**Figure 16-18: Mines Production Profile** (Eldorado 2024)

Figure 16-19 summarizes the distribution of ounces extracted by mining method.

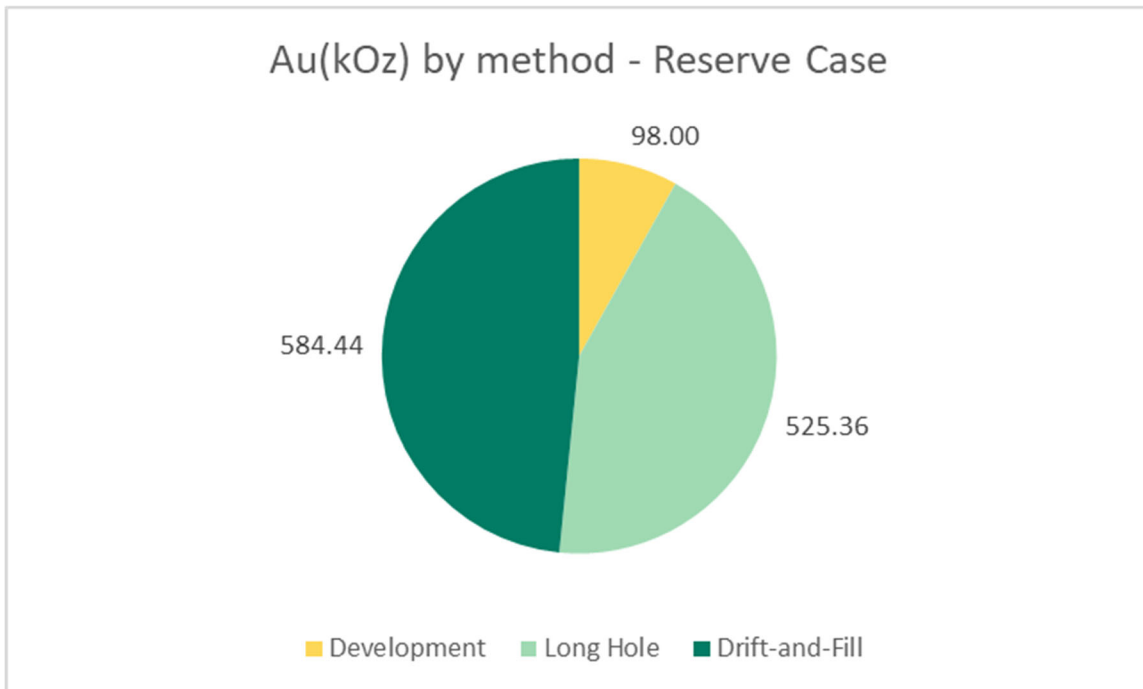

Mining factors are applied on ounces displayed (dilution and ore losses)

**Figure 16-19: Distribution of Ounces by Mining Method** (Eldorado 2024)

## 16.8 Mine Equipment

### 16.8.1 Mobile Equipment

The mobile equipment requirements for development, production, and support services are listed in Table 16-20. The equipment list is based on the current fleet for the upper Triangle operation and has been updated to include the satellite deposits; Ormaque, Parallel, and lower Triangle.

Ormaque requires specific equipment to mine low height drifts in ore zones, especially for bolting and jumbo drilling. Case 1 will leverage on transferring some equipment from Triangle to Ormaque as the Triangle mining rates decrease. Major additional equipment for Case 2 will include jumbos, bolters, LHDs, and trucks. Since Triangle will maintain a higher mining rate at higher depth compared to Case 1, less equipment will be available for transfer to Ormaque.

**Table 16-20: Lamaque Complex Mobile Equipment List**

Activity	Type	Model	Current Fleet	Max Fleet
Development Drilling	1-Boom Jumbo	S1D	1	1
	2-Boom Jumbo	M2C	2	2
	2-Boom Jumbo	S2C	3	4
Ground Support	Bolter	Maclean MEM-928 and MEM975	8	8
	Small Section Bolter	Maclean SSB	0	3
	Cable Drill	Machine Roger	1	1
		CMAC SPLH II	1	1
Blasting	Explosive Vehicle	PAUS	1	1
		Minecat	1	1
		Maclean CS3	1	3
Mucking	LHD – 8yd	CAT R1700K	1	1
		SDK LH514	3	3
		SDK LH515i	2	6
		CAT R1700G	3	3
	LHD - 11yd	CAT R2900G	3	3
Hauling	Haul Truck 30T	CAT AD30	2	2
	Haul Truck 45T	CAT AD 45	4	4
		SDK TH545I	5	8
	Haul Truck 50T	TH550B	2	2
Production Drilling	Long Hole	SDK DU-311	1	1
		CUBEX (contractor)	3	3
Support Vehicles	LHD - 3yd	CAT R1300H	2	3
	LHD – 6yd	CAT R1600H	3	3
	Block Holer	Maclean BH3	1	1
	Scissor Lift	Maclean SL2, SL3	6	11
	Telehandler	Manitou / Bobcat	3	3
	Flatbed Boom Truck	MacLean BT3	3	4

Activity	Type	Model	Current Fleet	Max Fleet
	Grader	CAT MC100	2	3
	Blockholer	BH3	2	2
	Cement Mixer	MacLean TM3	4	4
	Backhoe	CAT420Fit / John Deer 310	4	4
	Shotcrete Sprayer	Swatcrete	1	2
	Service Truck	CS3	3	3
	Mine Rescue	PAUS Minca 18	1	1
	Tractor	Kubota	35	38
	Jeep	Toyota	24	33
	Surface Front Loader	Volvo / Neuson / Komatsu / CAT / Yanmar	8	8

## 16.9 Ventilation

The current ventilation system for the upper Triangle deposit is a “push” system with the fresh air heated, as required on surface. The main fans push the air through the fresh air raise (FAR) and subsequently deliver it to the working areas of the mine. The used / exhaust air from the mine is then upcasted through the ramp and exhausted at the Triangle and Sigma-Lamaque portals.

As mining of the Triangle deposit progress deeper, booster fans are added in the FAR system.

The Ormaque deposit will have an independent FAR with dedicated main fans and heaters. The heaters and E-house will be located on surface while the fans will be installed underground to minimize noise nuisance issues. Air will be “pushed” into raises and distributed from FAR to levels following production demands. Used air will be directed into the Ormaque internal ramp toward the Sigma-Triangle decline. Total estimated ventilation requirements include 350 kcfm for Ormaque and 1,100 kcfm for Triangle, based on CANMET (Canada Centre for Mineral and Energy Technology) airflow requirements for diesel engine equipped equipment. A schematic outlining the major ventilation infrastructure for the ventilation system of the Lamaque Complex, including the Ormaque and Triangle deposits, is provided in Figure 16-20. An additional booster fan will be required underground within the exhaust system for Triangle to boost the pressure in the exhaust network and allow the ventilation for Triangle to be maintained.

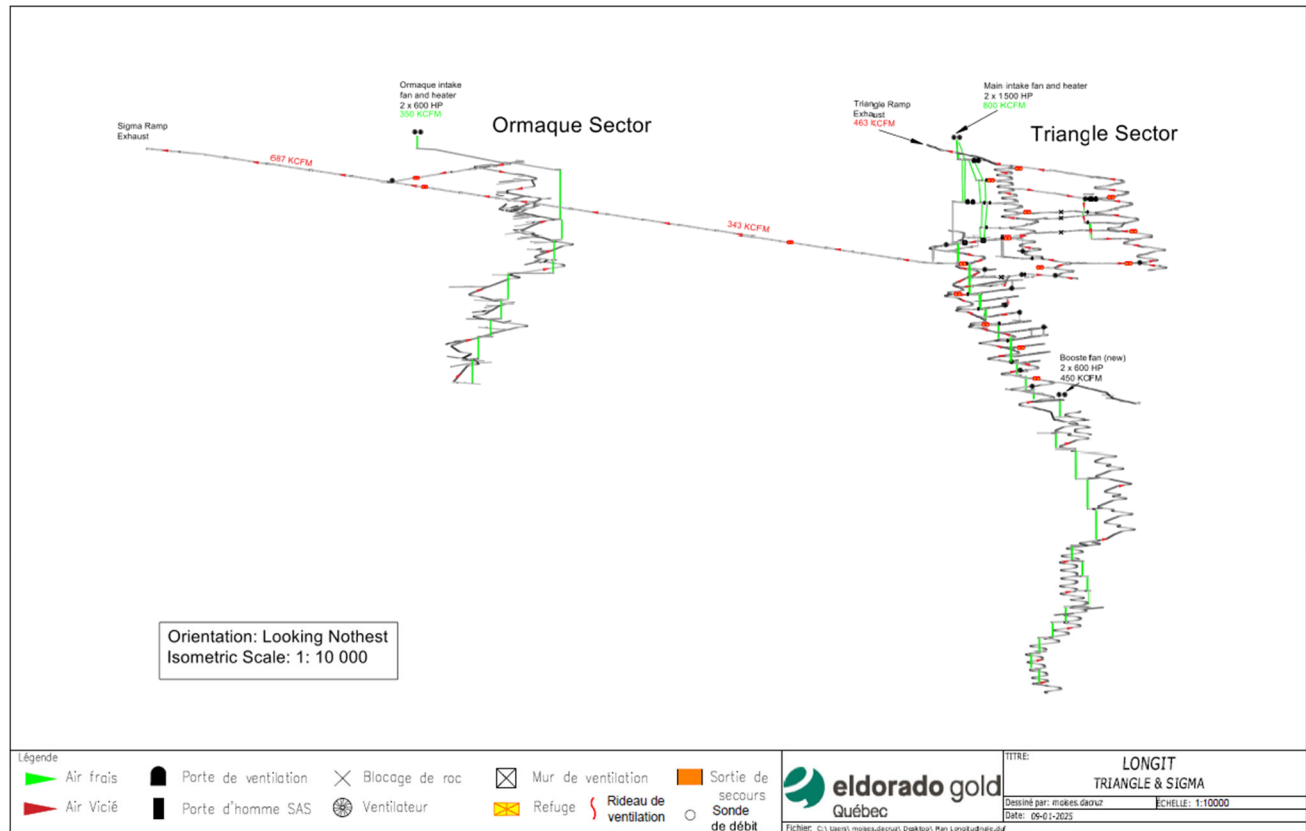

Figure 16-20: Ventilation Network for Lamaque Complex (Eldorado 2024)

## 16.10 Geotechnical Assessment

Development and mining the deposits on the Lamaque property, apart from Ormaque, comply with the Geotechnical Ground Control Management Plan (GCMP), “Programme en Contrôle de Terrain 2024”. The Ormaque GCMP will be published when further geotechnical data is collected prior to commercial production. As described in Section 7.3.2.3, the Triangle deposit orebodies are located either in the volcanoclastics units, or in the Triangle Plug or marks the contact between the two units. As for the Ormaque deposits, all the orebodies are totally contained inside the C-Porphyry unit, as described in section 7.3.2.6.

### 16.10.1 Rock Mass Quality

The Geology department collects relevant data from DDH core logging and underground mapping. This data includes RQD, stratigraphic data, and geological structures that populate a dedicated database.

Rock mass classification is obtained by completing dedicated tests and field observation. Lab testing provides quality information to evaluate intact rock and Hoek-Brown parameters.

The geomechanical properties used of the Triangle diorite/tuff are presented in Table 16-21 and Table 16-22.

Table 16-21: Geomechanical Properties of Triangle Diorite / Tuff

Parameters		Queen's 2014 & Golder 2015		Englobe 2019					
		C1 to C6		C7 to C10					
		Representative Range	Mean Value	Representative Range			Mean Value		
				T Ap	T to BI	I2JT	T Ap	T to BI	I2JT
Intact Rock Parameters	Uniaxial Compressive Strength (UCS) Mpa	100 to 200	145	98 to 442	67 to 204	1	313	157	55
	Young's Modulus (E) Gpa	30 to 40	35	46 to 92	42 to 64	1	69	56	55
	Poisson's Ratio ( $\nu$ )	0,10 to 0,25	0.15	0,25 to 0,30	0,19 to 0,22	1	0.28	0.2	0.2
	Density (t/m <sup>3</sup> )	2,7 to 1,0	2.8	2,82 to 3,12	2,75 to 2,91	1	2.99	2.89	2.62
Hoek-Brown Parameters	Triaxial Compressive Strength ( $\sigma_{ci}$ ) Mpa	166 to 189	175	179 to 483	187 to 358	1	380	292	260
	Tensile Strength ( $\sigma_t$ ) Mpa	8 to 16	13	15,2 to 24,8	11 to 31,1	11 to 15,6	20.7	17.1	13.3
	Material's Coefficient (mi)	13 to 16	14	-	-	-	13.3	13.3	15.1

Table 16-22: Hoek-Brown and Mohr-Coulomb parameters

Hoek -Brown Classification	
UCS of intact rock (MPa)	145
GSI	78
$m_i$	19
Disturbance factor	0
Intact modulus (MPa)	20,000
Hoek -Brown Criterion	
$m_b$	8.66
S	0.08668
A	0.501
Mohr-Coulomb Fit	
Cohesion (MPa)	13,63
Friction angle	44.267 <sup>0</sup>
Rock Mass Parameters	
Tensile strength (MPa)	1.453
Modulus of deformation (MPa)	17140.791
Uniaxial compressive strength (MPa)	42.64
Global strength (MPa)	64.64
Failure Range Envelope	
Sigma3 (Max) (MPa)	36.25
Application	General

### 16.10.2 Rock Mass Classification

Rock mass classification is obtained by combining intact and joint rock properties such as RQD, number of joint sets, their roughness, their alteration, water presence and a stress parameter. Two indexes are widely used, the NGI Q' and RMR system. These values are evaluated for each rock type. They are a requirement to determine any ground support system.

### 16.10.3 In-Situ Stress

In-situ stresses are natural forces that are present in the rock mass. That can affect ground stability. Regional stresses evaluation was evaluated with time by independent research. The values for any initial high level stress modeling are shown in Table 16-23.

Table 16-23: Regional Natural Stresses

Parameters		Minor Principal Stress ( $\sigma_v$ or $\sigma_3$ , Mpa)	Major Principal Stress ( $\sigma_h$ , Mpa)	Maximum Stress ( $\sigma_H$ , Mpa)
Arfang 98	Intensity	$\sigma_v$ or $\sigma_3 = 0.028 \times Z$	$\sigma_{h2} = 1.3 \times \sigma_3$	$\sigma_{H1} = 1.9 \times \sigma_3$
	Direction	Vertical	East - West	North - South
	Dip	90°	0°	10°
Cammet 95 - 97	Intensity	$\sigma_v$ or $\sigma_3 = 0.028 \times Z$	$\sigma_{h2} = 1.6 \times \sigma_3$	$\sigma_{H1} = 2.5 \times \sigma_3$
	Direction	Vertical	East - West	North - South
	Dip	90°	-	-

### 16.10.4 Geotechnical Model

The geotechnical model developed contains data related to structures. It includes major and minor discontinuities. The model was refurbished in 2022 by ASA Geotech an external specialized and renowned firm. Results concluded that nine structure families are present. Of that number, two are considered major and pervasive. Refer to Table 16-24 for major and minor structure families.

Table 16-24: Major and Minor Structures Families

Set	Type	Typical spacing	Azimuth Median	2-3 Quartile		Dip Median	2-3 Quartile	
CIS C&S	Major	Pervasive	187.1	+/-	8.9	68.7	+/-	6.8
CIS TH	Major	Pervasive	187.6	+/-	13.8	38.0	+/-	10.0
J1	Minor	10m, irregular	245.9	+/-	8.0	64.5	+/-	11.1
J2	Minor	4-10m (mapping)	154.8	+/-	15.5	71.8	+/-	7.7
T	Moderate	Variable	350.0	+/-	20.0	28.0	+/-	15.0

### 16.10.5 Ground Support

Triangle slope wall stability is determined using Mathews-Potvin abacus and the N' stability index. The abacus shows that slope walls are stable up to a 25 m x 25 m span. Support for slope hanging walls is individually designed for identified local structures. Parameters are shown in Table 16-25.

Table 16-25: Ground Support Parameters

	Hanging wall	Foot wall	Roof	Abutment
A	1	1	0.1	0.1
B	0.2	0.2	0.2	0.2
C	3.5	5	2	8
Q'	10-30	10-30	10-30	10-30

All underground infrastructure and accesses use ground support specific to the opening. To assure stability, up to four methods are used: local support (bolts and cables), surface support (screen, shotcrete), built structures (concrete arches) or a combination of methods.

The method selection is based on local geology, present and future induced stress, usage, lifespan, installation method and support function. Support designs key parameters are bolts (density, length, types, steel properties), surface support type and thickness, and finally the covered area.

## 16.10.6 Ormaque Geotechnical Considerations

### 16.10.6.1 Rock Mass Quality

Rock Quality Designation (RQD) was established from 1,543 m of representative DDH drillholes. Core integrity was good at 98% with an average joint spacing of 1.4 m.

Strength was mainly determined using geology hammer blows using field assessment of rock strength (ISRM, 1981). From this method, an averaged rock strength of 100 MPa was obtained. Some smooth chlorite infilled joints are observed penalizing joint conditions. The next phase will include laboratory testing that will enhance rock strength estimation representativeness. Strength estimates between mineralized zone (shear) and host rock (diorite) are somewhat similar with diorite slightly stronger as shown in Figure 16-21.

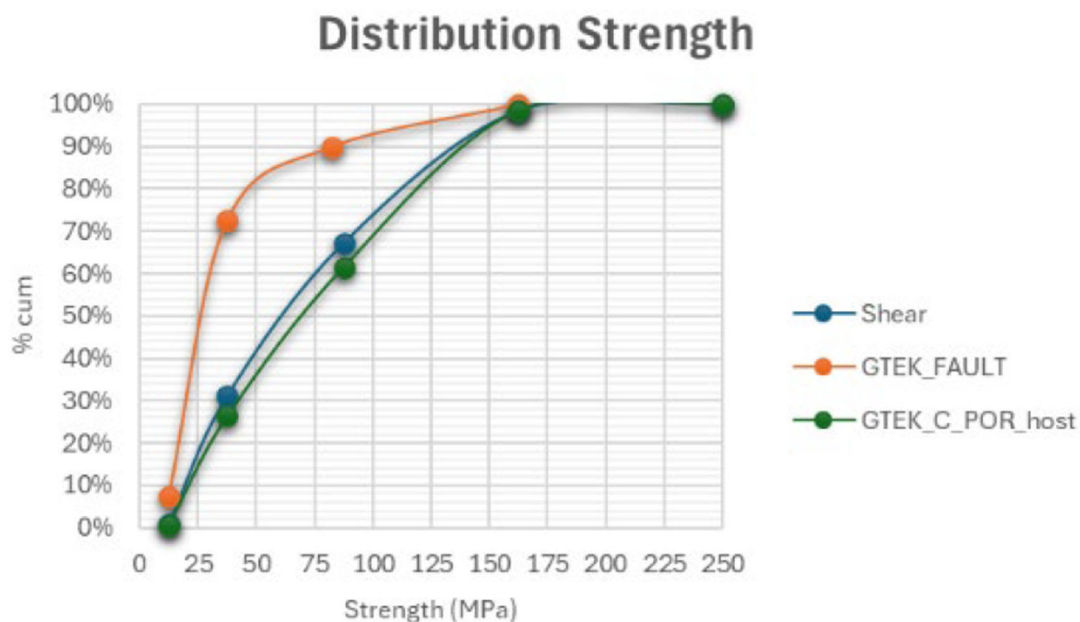

**Figure 16-21: Field Strength Distribution per Domain (Eldorado 2024)**

Some preliminary laboratory tests, including 17 UCS (but no triaxial tests) were conducted to compare with field assessments to review some parameters for initial RMR89 estimation, have a better understanding of the rock mass assumptions for further stress analysis modelling, and to populate the Mohr-Coulomb failure criteria. They targeted diorite host rock between lenses and mineralized shear zones. UCS average values range from 75 to 100 MPa which corresponds reasonably well with field tests.

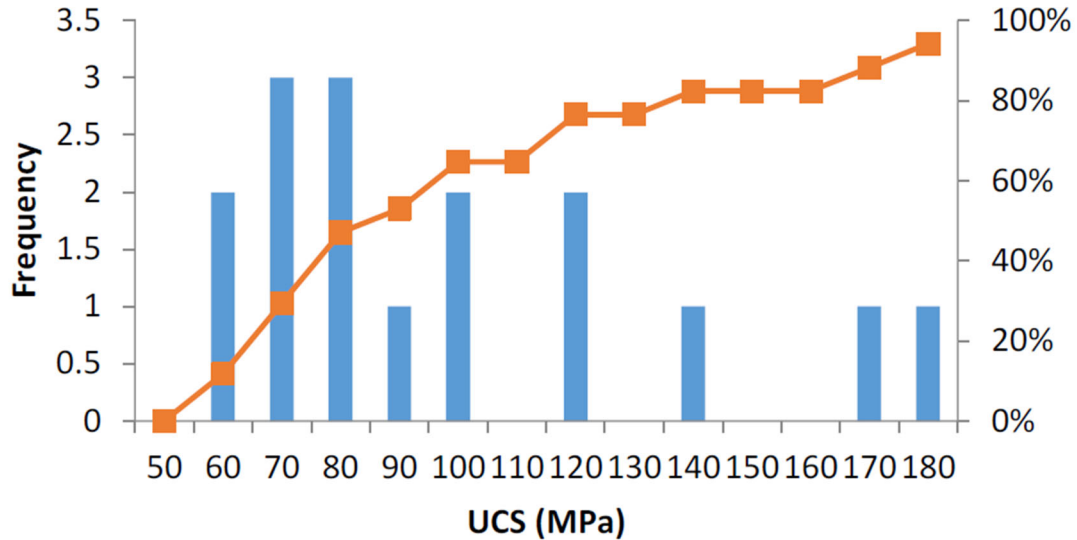

Figure 16-22: UCS Lab Tests (Eldorado 2024)

### 16.10.6.2 Rock Mass Classification

At Ormaque,  $RMR_{89}$  is used as the classification system. This system includes five parameters; RQD, joint frequency, rock strength, joint condition, and presence of water.

Results obtained from the campaign shows values ranging from 70 and 80 for the diorite. The fault domain shows values from 25 to 85, and the mineralized zone represented by the horizontal shear shows a skew distribution suggesting competency contrast within the domain.

At this stage, the following values are allocated to different the rock types shown in Figure 16-23:

- Host: 70 – 80 based on mean, median and mode values
- Faults: 65 – 75 based on median and mode values
- Shears (mineralized): 70-75 based on median and mode values

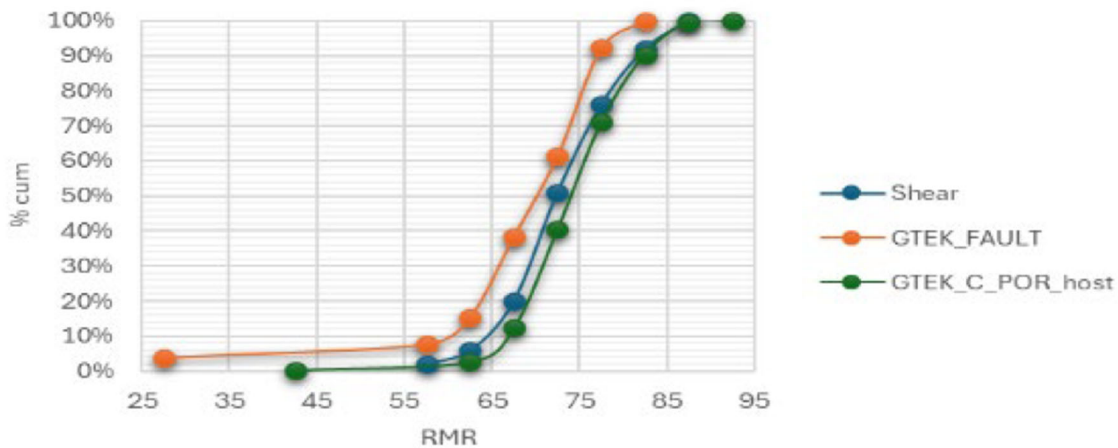

Figure 16-23: RMR Distribution per Domain (Eldorado 2024)

### 16.10.6.3 Geotechnical Model

The current initial geotechnical model uses structures and RQD tabs to look at potential alignment to define and constrain the model. The interpretation shows a potential of five distinct structures, as illustrated in Figure 16-24.

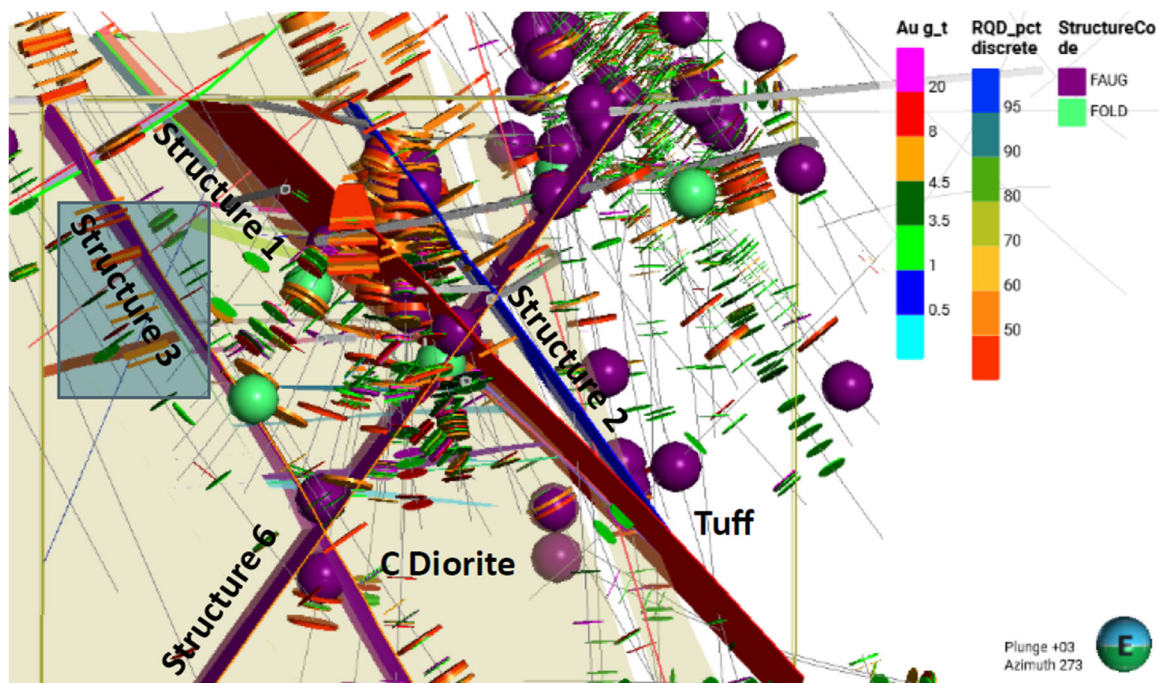

Figure 16-24: Cross-section Showing Information used for Preliminary Structural Model (ASA Geotech 2024)

Geotechnical domains in the models include the shear zone and host rock.

It is assumed that the sub-horizontal shear zones will behave differently to stress conditions and that the orientation of ground conditions possibly follows the sub-horizontal shear. The host rock includes porphyry C diorite and tuff. Tuff is far field of the intended mining and is not a significant concern currently. The porphyry C diorite is well characterized in near field to the veins. Far field is minimal at this time.

The current model includes three different entries: lithology with two domains, faults with five individual domains and shears/veins with 17 individual domains.

The most significant stress is the vertical component of the tensor. Shallowness of the deposit counters its effect. The flat dipping tabular lens of the deposit is less subject to the regional higher horizontal component.

The flat dipping tabular lens of the deposit is less subject to the regional higher horizontal component. Mining with the DAF mining method will shift stress to the abutments. Subsidence may loosen ground promoting convergence.

Mining sequence will account for each lenses proximity to each other to avoid geomechanical issues and potential ground failure.

#### 16.10.6.3.1 Ground Support

Recommended rock support is adjusted to opening type and duration. In all designs, modern mechanical bolts are mandatory, even in the thinner ore lenses. The rock support system is based on available geotechnic data such as RQD and RMR<sub>89</sub>. Qualitatively, the rock, both host and mineral zones are considered Good to Very Good rock material and fault systems considered Fair Ground.

- Short term ore drifts
  - Ceiling – 1.5 m rebar No. 6 on a 1.2 m × 1.2 m square pattern with No. 9 gauge screen
  - Wall – 1.5 m 35 mm split set on a 1.2 m × 1.2 m square pattern screenless
- Long term waste infra
  - Ceiling – 2.3 m rebar No. 7 on a 1.2 m × 1.2 m square pattern with No. 6 gauge screen
  - Wall -1.8 m 35 mm split set on a 1.2 m × 1.2 m square pattern with No. 6 gauge screen

Resin grouted cable bolts are installed in wider openings or intersections on a 2.0m × 2.0 m pattern.

Analysis conducted with UnWedge™ and numerical analysis software were used to asses any stress related potential issues.

Backfilling the drifts to as close to the back as possible provides confinement against unraveling. Shotcrete post pillars may be required in dedicated sectors in primaries to assure global stability for larger lenses.

### 16.11 Mine Services

Upper Triangle has established operating mine services (i.e., dewatering, compressed air, etc.) These systems will be extended to lower Triangle, Ormaque and Parallel as mining progresses.

#### 16.11.1 Dewatering

The purpose of the underground mine dewatering system is to collect the used service water (water used in drilling operations and wetting muck piles), groundwater infiltration, and decant water from stope fill operations in the underground mine (collectively mine water). The system will be a “dirty” water system, meaning that there will be only minor attempts to settle or remove solids from the majority of the dewatering stream underground until the mine water reaches the Sturda weir system located in the access ramps to the Ormaque deposit. Mine dewatering efforts below the Sturda weir will not attempt to remove solids from the mine water streams. Sturda weir decant drifts will be used to settle solids. With this type of system, maintenance of the decant drifts should be completed on a regular basis. Sumps are to be mucked to remove dewatered grit and fines and/or fibers if fibers are used in the shotcrete.

In the ramp development period, mine water collected at the ramp face will be pumped to the Sigma ramp dewatering system where it will be directed to surface water treatment facilities for treatment, re-use, or discharge. As the ramp is developed downward, pocket and/or borehole sumps will be developed in excavated muck bays. Submersible pumps will pump water from the development face up to the closest pocket sump / muck bay and the submersible pumps there will then pump to the Sigma ramp dewatering system. As further ramp development continues, additional pocket sumps will be excavated until the primary pumping station and decant drifts are developed and commissioned. Primary pumping stations will be constructed at 200 m vertical intervals, nominally bypassing the development pocket sumps and submersible pumps. Water pumped from the development faces will pass through conditioning equipment at the upper primary pumping station, where appropriate flocculants and/or coagulants are introduced to the flow stream and will then be placed in the decant drifts. See Figure 16-25 for a layout of the decant drifts.

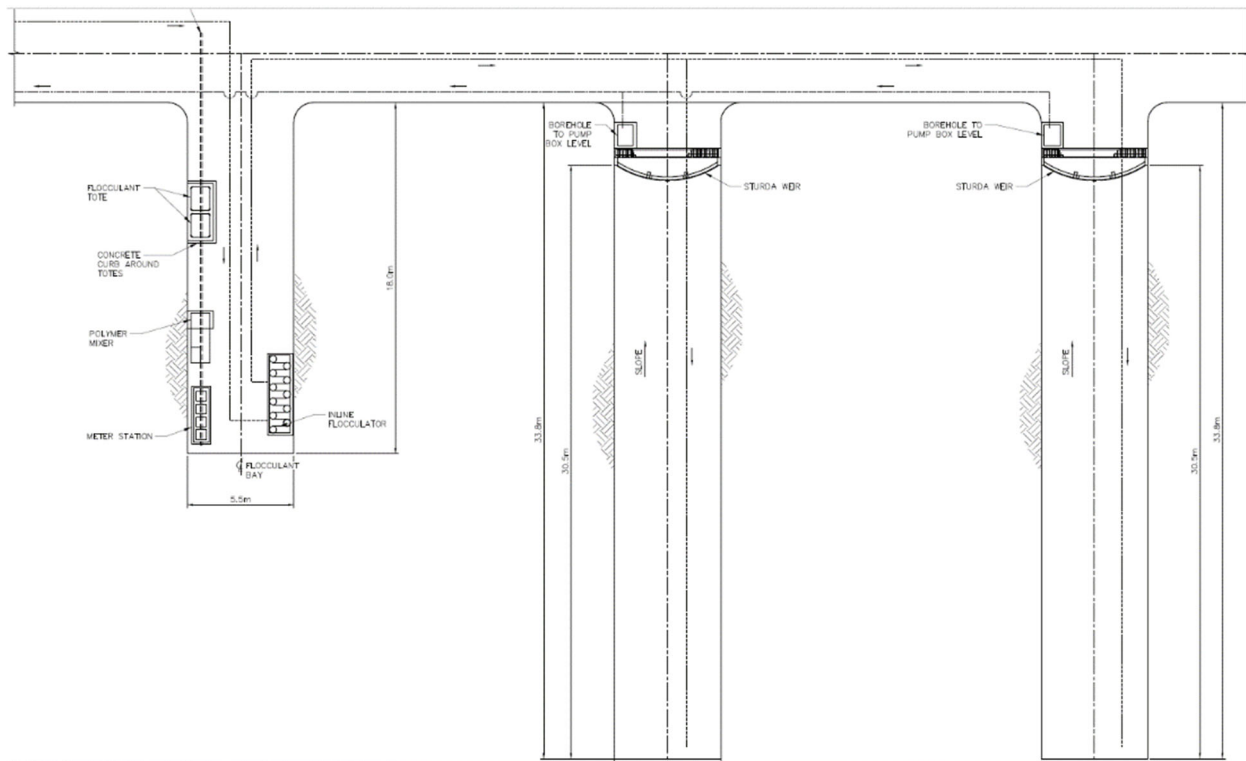

**Figure 16-25: Typical Decant Drifts (Eldorado 2024)**

The primary pump station will collect decant water from the decant drifts. The centrifugal pumps in the primary pump station will pump it to the surface water handling facility. The pumps will be installed as an n+1 scheme. See Figure 16-26 for a layout of the primary pump station.

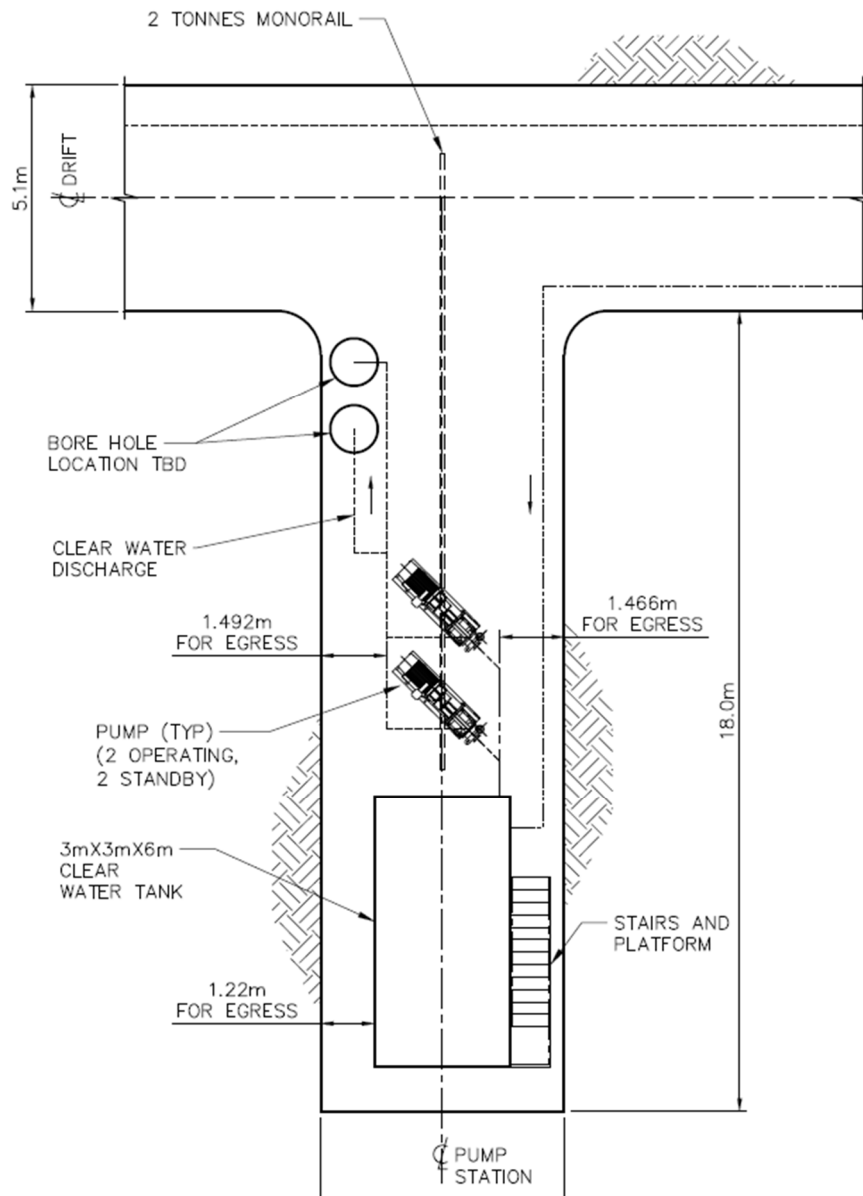

**Figure 16-26: Typical Primary Pump Station (Eldorado 2024)**

Each development level of the mine to access the mineralized lenses will collect mine water that will gravity flow to a collection sump in the footwall drift near the ramp access. The collection sumps will have the ability to de-grit the collected water before transferring water to the next lower level via borehole, until it reaches another primary dewatering pump station. The dewatering pump station will then pump up to the previously installed dewatering pump station, following the same process until the water reaches decant system at the Ormaque deposit accesses. See Figure 16-27 for a section view of a borehole sump.

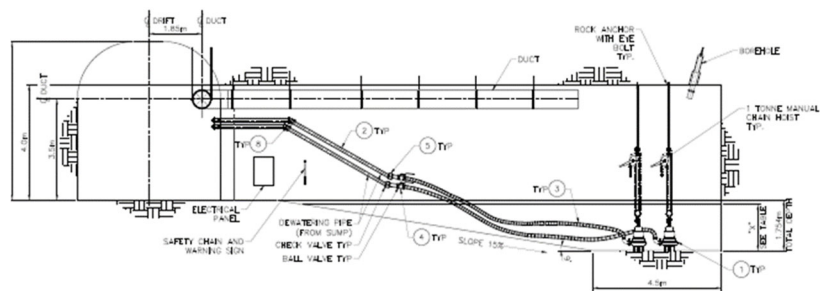

Figure 16-27: Typical Borehole Sump (Eldorado 2024)

### 16.11.2 Compressed Air

The compressed air supply for the mine is provided by four 1,476 cfm compressors located in the newly built compressor room on surface. The piping for the compressed air network is installed along the ramp, the main drifts and the escapeways throughout the mine. The compressed air is used to provide power to pumps for dewatering, handheld drills, as well as emergency air supply to refuge stations. Ormaque will have its own dedicated air compressor unit.

### 16.11.3 Industrial Water

To provide service water for Ormaque, a water basin will be constructed in the exploration drift on level 90 to collect decanted water from natural inflow. This will be connected to the decline service water lines that will run the full length of the Ormaque mineralized lenses. There will be Pressure Reducing Valves (PRVs) located every 360 m down the decline to maintain pressure at levels that may be deployed without endangering workers. Branches from the decline header will drop down to a utility station located every 100 m and to any additional equipment that requires service water. Utility stations are also spaced so there will be one at each collection sump. There will be branches from the decline header that provides service water to each development level. Water demand for Ormaque was calculated using first principles and has a peak water requirement of 5.4 liters per second and an average requirement of 3.4 liters per second.

### 16.11.4 Explosives / Detonator Storage

Explosives and detonators will be stored separately in different excavations. Blasting agents are stored in the explosives magazine on level 425, which has a capacity of 135,000 kg. The detonators and blasting accessories are stored in the detonator magazine on level 425 with a capacity of 625,875 units.

An additional explosives / detonator storage will be built in Ormaque at level 405 to support operation.

### 16.11.5 Underground Power Distribution

#### 16.11.5.1 Distribution

The distribution will be at 13.8 kV with two feeders to provide redundancy. One feed will be supplied from each portal. The two medium voltage power feeds are used to segregate the MLC loads. If one feeder is compromised, the other is available, minimizing the outages. Breakers and isolation switches are required to sectionalize the distribution for safety. Grounding will be established on the surface at the Main Mine Utility substation and carried continuously throughout the mine.

The UG at full production requires approximately 5.2 MW of energy with an installed load of 8 MW.

The Lamaque Complex has a 25 kV supply with a capacity of 18 MW. Greater loads would require connection to the higher voltage distribution which is available.

The present average load for surface operations is 11 MW and adding the nominal 5.2 MW totaling 16.2 MW for the Lamaque Complex, below the 18 MW capacity. The present capacity is sufficient. However, this does not allow for much variation or future expansion

It is recommended that in the next study phase the new project power requirements be modelled with the overall mine load projections to raise confidence in the supply capacity meeting the needs of the total mine.

### 16.11.5.2 Mine Load Center

A mine load center (MLC) is a skid mounted unit substation consisting of a feed through switch, fused disconnect transformer protection, 13,800 / 575 V transformer with a neutral grounding resistor and 575 V 3 phase feeder circuits.

MLCs will be installed close to the intersection of the ramp and each level. The pumping stations are also located close to the ramps and are fed from MLCs. Ventilation fans and pick-up pumps are fed from MLCs. Where development and production activities are greater than 1,000 ft (nominally 300 m) from the MLCs, a second MLC will be installed.

Production MLCs may feed 575 V from one level to the next level through short boreholes to a jumbo box which is an isolator with overcurrent, ground fault, and ground monitoring protection.

The mine load center is sized for the loads defined in the load list and will nominally be 750 kVA.

Not all the loads are continuously operating. For this study, the sizing will be standardized for all MLCs. MLCs will have feed-through medium voltage (MV) breakers and dry type transformers. Low voltage (LV) feeds will have mine duty receptacles and be protected by overcurrent and ground fault and ground monitoring. Surge arresters will be connected to the MV bus.

The main pumping and ventilation loads are designed with Variable Frequency Drives (VFDs) to minimize high starting loads to the system and control flow to optimize energy use.

### 16.11.5.3 Emergency Loads

It is considered an electrical emergency when utility power is lost. It is assumed that production stops and only life critical services are maintained. Typically, life / critical services are ventilation and pumping. Personnel either evacuate by vehicle up the ramp or by walking out. Ventilation is critical and is nominally maintained at 50% of operating when ventilation doors and regulators are set to optimize air flow. Pumping is maintained to avoid flooding.

Diesel emergency backup generators are sized to meet the calculated emergency loads, plus an additional 20% to accommodate any unforeseen increases and changes in loading. Diesel tank storage capacity would typically be 8 hours minimum or twice the time it would take the fuel supplier to refill the tanks. There would be N+1 generating units to allow for maintenance.

It is calculated that surface generators totalling 4.5 MVA operating are required for full production phase. This capacity could be split between the portals if the distribution system is designed for this.

## 16.11.6 Underground Communication

All communication is provided by fiber optic and “leaker feeder” networks. These systems support voice communications, PLC monitoring, and control, video, operation data and to control and monitor the electrical network.

Personnel will carry leaky feeder radios and vehicles will be equipped with base units.

The fiber optic data backbone can also support control and communications systems. Wi-Fi Access points for data collection, VOiP phones, tablets etc.

## **16.11.7 Mine Safety**

### **16.11.7.1 Fire Prevention**

As prescribed in the regulations and best practices, fire extinguishers are provided and maintained for underground refuge stations, electrical substations, pump stations, fueling stations, explosives magazines, detonator magazines, and other areas. Every vehicle will be required to carry at least one fire extinguisher. Additionally, large underground heavy equipment, such LHDs, haulage trucks, and jumbo drills, will have an automatic CO<sub>2</sub> fire suppression system installed.

### **16.11.7.2 Mine Rescue**

A fully trained Mine Rescue Team is already in place and the mine is equipped for surface and underground emergencies.

### **16.11.7.3 Refuge Station**

Triangle refuge stations are located on levels 94, 135, 195, 238, 300, 325, 375, and 410. Permanent refuge stations are sealable chambers that prevent the entry of gases. They are equipped with compressed air, potable water, and first aid equipment. There are portable refuge stations additionally available to be moved to new locations as the work and areas advance.

The main ramps will provide primary egress from the underground workings. The FAR system will be equipped with a dedicated manway to provide secondary egress in case of emergency. The manway is equipped with steel ladders and platforms.

Ormaque refuge stations will be located on levels 230, 325, 440, 520, 630 and 800. The main ramps will provide primary egress from the underground workings. Dedicated raises will be used as secondary egress escapeways using the SafeScape technology.

### **16.11.7.4 Emergency Stench System**

A stench gas injection system is installed on each fresh air intake and compressed air delivery circuit and can be triggered to alert underground personnel in the event of an emergency.

## 17 Recovery Methods

### 17.1 Introduction

The Sigma mill has a demonstrated annual throughput capacity above 900 ktpa, dependent on ore type and plant availability. In the current plan, the mill is expected to operate at a similar throughput. With a mill availability of 95% the required plant throughput is 110 tonnes per operating hour (tpoh). This is below the best 30-day average throughput reaching 121 tpoh in December 2024. Minor investments for debottlenecking will be planned and executed to ensure the processing capacity keeps pace with increased mine production.

This section describes the process equipment available at the Sigma mill as well as some planned modifications that will improve availability and processing capacity.

This section also discusses and presents the following items:

- The estimated gold recovery, considering the metallurgical testwork and processing results obtained to date
- A summary of the process design criteria
- Mass and water balance
- A list of the major plant equipment
- Operating costs including required plant personnel, energy, consumables
- Plant layout

#### 17.1.1 Sigma Mill Process Description and Flowsheet

The Sigma mill is situated at the East entrance of the city of Val-d'Or. The process plant started operation in 1937 and the plant capacity and flowsheet have been modified several times over the years. A complete rebuild of the facility was completed before operations restarted in March 2019. The current configuration of the process uses two-stage crushing followed by primary grinding through an open circuit rod mill and closed-circuit ball mill, then secondary grinding through a closed-circuit ball mill. Gold is recovered by a gravity concentration circuit, and by a cyanide leaching and carbon-in-pulp circuit with subsequent gold refining. The Sigma mill simplified flowsheet is provided in Figure 17-1.

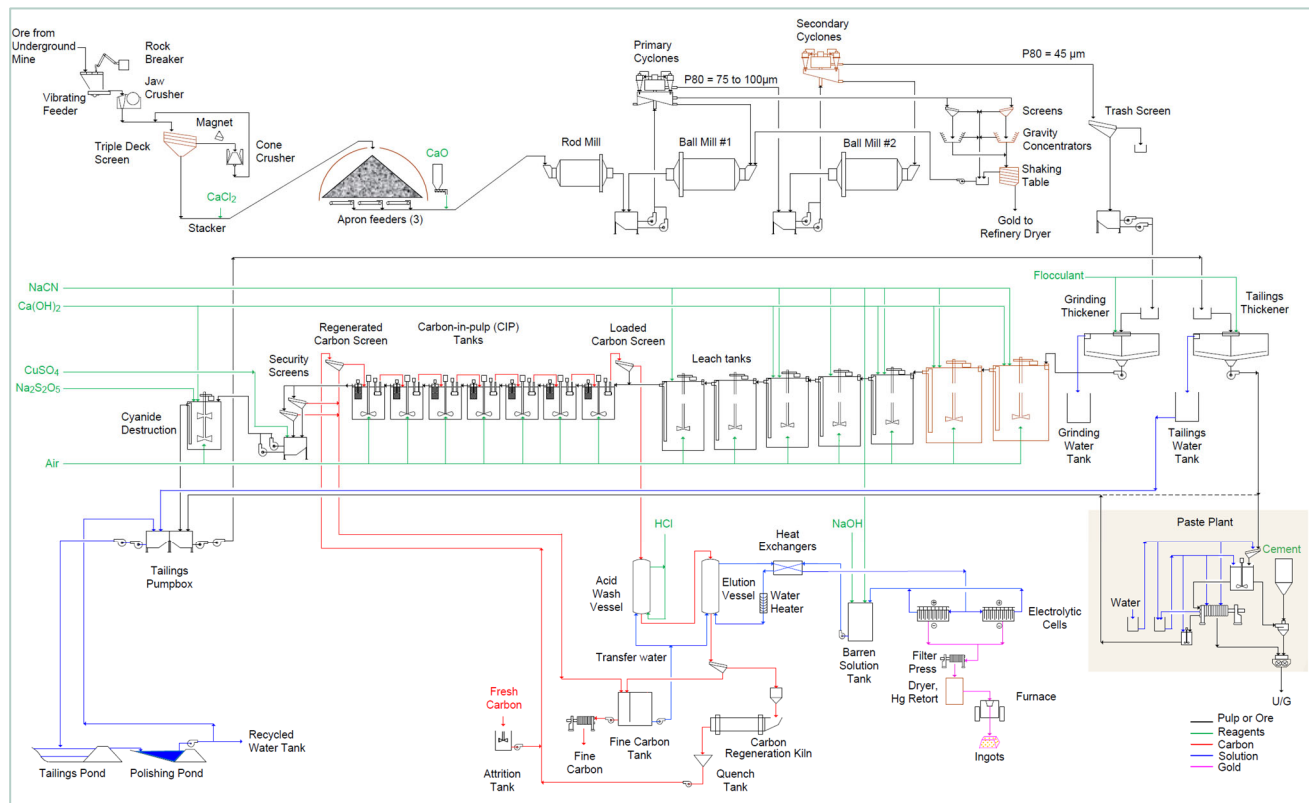

Figure 17-1: Sigma Mill Simplified Flowsheet (Eldorado 2024)

### 17.1.2 Crushing Circuit

Ore from the mine is trucked to the Sigma mill site 24 hours per day. The crushing circuit is operated during a 12-hour day shift and consists of a grizzly screen, a rock breaker, a 110 kW crusher with an opening of 1,120 mm × 870 mm, and a 294 kW secondary cone crusher in closed circuit with a triple deck screen. The final screened product is conveyed to the covered stockpile.

In the winter, calcium chloride is added to the crushed material on the conveyor belt to prevent ore freezing and potential material handling problems.

### 17.1.3 Ore Storage

The mill is fed from a covered stockpile above a reclaim tunnel equipped with three apron feeders.

A 100-tonne quicklime silo is located near the ore storage silo and feeds solid quicklime via a screw feeder directly onto the ore silo discharge conveyor.

### 17.1.4 Grinding Circuit

The grinding circuit includes a 2.74 m × 3.65 m, 300 kW rod mill and a 3.51 m × 4.27 m, 750 kW ball mill. The rod mill operates in open circuit and the primary ball mill is closed with cyclones. A portion of the cyclone underflow is sent to the gravity circuit with the remainder returned to the primary ball mill. The cyclone overflow, with a grind size P80 of 75 µm to 100 µm, proceeds to the secondary ball mill pumpbox.

The secondary ball mill is 3.66 m × 4.27 m, 930 kW and operates in closed circuit with a second set of cyclones. The targeted grind size from the secondary ball mill is a P80 µm of 40 µm. The secondary cyclone

underflow is returned to the mill for further size reduction while the overflow is directed to the trash screen to remove debris. The trash screen underflow is pumped to the production thickeners.

A lead nitrate system, incorporating a bag discharge hopper, mixing tank, transfer pump, storage tank, and dosage pumps, is installed in the grinding circuit but it is currently not in use.

### 17.1.5 Gravity Circuit

The gravity circuit incorporates a static screen and two gravity concentrators, each capable of 80 tonnes/hr solids. The gravity concentrate is treated on shaker tables with the table concentrate further processed in the refinery.

### 17.1.6 Thickening

The trash screen underflow is pumped to the pre-leach thickener feed box. A sampler and particle size monitor are installed on this line. The plant is equipped with two 9.14 m (30 ft) diameter high-rate thickeners. Flocculant is supplied to the thickeners using a flocculant preparation system. Thickener overflow gravity feeds into the grinding water tank and underflow from the thickeners is pumped to the first leach tank.

### 17.1.7 Leach Circuit

After thickening to approximately 50% solids, the underflow slurry is pumped to the leach circuit where cyanide is used to dissolve the gold. The circuit currently consists of seven tanks with a total of 10,475 m<sup>3</sup> active leach volume. At current processing rates, this translates to a leaching residence time of over 70 hours.

Slurry flows from one tank to the next by gravity. Every tank can be by-passed to allow maintenance on any given tank. Each tank is equipped with an agitator mechanism and compressed air lines. A second 40 tonne quicklime silo was recently installed near the main plant building to feed a lime slaker and milk of lime storage tank and distribution pumps. The milk of lime is used for pH control in the leach and cyanide destruction circuits.

### 17.1.8 Cyanidation

Sodium cyanide is fed to the leach circuit as well as the elution circuit. The sodium cyanide tank is in an annex of the mill building with its own containment area and truck delivery pad. The same pad is used for sodium cyanide, sodium hydroxide and lime deliveries.

### 17.1.9 Gold Extraction Circuit

The leach circuit discharge first flows through a sampler before feeding the carbon-in pulp (CIP) circuit, composed of one larger 280 m<sup>3</sup> tank and six smaller 170 m<sup>3</sup> tanks. The slurry flows from one tank to the next by gravity. Every tank can be by-passed to allow for maintenance on any given tank. New inter-stage screens were recently installed in each tank to prevent carbon from being transferred with the slurry. All tanks are equipped with agitators, compressed air lines and air distribution cones.

Carbon is pumped counter-current to the flow of slurry using vertical pumps. Fresh pre-atritioned carbon is fed to the last tank via the regenerated carbon vibrating screen which removes carbon fines prior to feeding the carbon to the CIP circuit.

After going through the CIP circuit, the slurry proceeds to two parallel vibrating safety screens used to recover any smaller carbon particles that may have passed through the inter-stage screens. The undersize from the

screens, which contain the slurry tailings, is fed into a pump box while the oversize, which contains fine loaded carbon, flows back to the fine carbon tank.

### 17.1.10 Elution and Carbon Regeneration

The carbon, elution and electrowinning circuits operate in batch. Gold loaded carbon is pumped periodically from the first CIP tank onto a screen, which returns the undersize slurry and residual cyanide solution to the same tank. The screen oversize, containing the loaded carbon, flows into a bin followed by the acid wash column, which soaks the carbon with hydrochloric acid for about 2 hours to remove inorganic contaminants and carbonates fouling the carbon. When the acid wash is completed, the loaded carbon is rinsed with water to return to a neutral pH before being transferred to the elution vessel.

From the acid wash column, the carbon is transferred into a 3-tonne capacity pressure elution column. Elution is carried out using the ZADRA process which uses a high temperature, high pressure sodium cyanide and caustic solution to elute gold from the carbon. The elution solution is prepared in the barren solution tank. The barren solution is then pumped through a heat exchanger, further heated using an electric heater, then through the elution column. The enriched solution then flows out from the top of the elution column and cooled through the trim heat exchanger before being transferred to the electrowinning cells.

Carbon from the elution column is transferred to a dewatering screen, with oversize carbon feeding the regeneration kiln and undersize flowing to the carbon fines tank. At the regenerating kiln, the carbon is heated to remove organic contaminants. The existing kiln is equipped with a 240-kW electric heater and can regenerate a maximum of 160 kg/h carbon.

The regenerated carbon exits the kiln and is cooled in a quench tank, and then returned to the regenerated carbon screen which feeds the last CIP tank. As required, fresh carbon will be fed to an agitated carbon attrition tank and pumped to the same CIP tank. Carbon fines collected from the regenerated carbon screen, the kiln feed dewatering screen and other carbon transfer waters are collected in the fine carbon tank. Bagged carbon fines are sent to a third-party smelter for processing.

### 17.1.11 Refining

The cooled pregnant solution from elution is pumped to the electrolysis cells located in the refinery. There are two electrowinning cells, running in parallel with stainless steel cathodes. During an elution cycle, elution solution flows continuously through the circuit and a fan is used to evacuate fumes from the electrowinning cells.

When the elution cycle is complete, barren solution from the electrowinning cells is pumped back to the barren solution tank and gold is removed from the cathodes by pressure washing in a wash booth. The resulting gold sludge is pumped to a filter press. The filter cake is dried, and any mercury in the ore is removed in a mercury retort unit before it is mixed with flux and melted in the induction furnace. A dust collector is used to treat the off gas from the induction furnace. The doré ingots poured from the furnace are stored in a vault. The retort unit and furnace are also used to treat the shaking table concentrate.

### 17.1.12 Cyanide Destruction and Related Reagents

CIP tailings from the safety screens undersize pump box are pumped directly to a cyanide destruction (detox) tank equipped with an agitator mechanism and a compressed air line. In cyanide destruction, reagents and air are used to reduce cyanide concentrations to environmentally acceptable levels. Sodium metabisulphite is used as the SO<sub>2</sub> source. Copper sulfate is added as needed to catalyze the reaction. Milk of lime from the new lime slaking and distribution system is used for pH control.

### 17.1.13 Tailings

The plant is equipped with two tailings pump boxes each connected to two tailings pumps in series with a third spare set of two pumps on standby. The plant tailings from cyanide destruction are currently being sent to the tailings pond via either of the pump boxes.

### 17.1.14 Water Supply Services

The plant is equipped with two water tanks, the grinding water tank, and the recirculated water tank. The grinding water tank collects water from the pre-leach thickeners and will collect some of the water from the tailings thickener once it is constructed. The recirculated water tank collects water from the tailings pond recovery basin, as well as water from the Sigma mine underground water line.

### 17.1.15 Air Supply Services

To meet the expanded leach, CIP, and cyanide destruction compressed air requirements, a third low pressure air compressor will be installed with two compressors in operation and one stand-by unit.

Plant compressed air to the concentrator will be supplied by two high pressure air compressors with one operating and one on stand-by. Additional compressors may be required for the future installation of the paste backfill plant.

Instrumentation air is supplied by the plant air compressors.

## 17.2 Metallurgical Recoveries

Metallurgical recoveries in the plant averaged 97.0% from 2019 to 2024. The plant has observed a seasonal fluctuation whereby higher recoveries are obtained during the warmer summer months with lower recoveries in the winter months. This was also confirmed in recent metallurgical testwork under varied temperatures. The expected recovery for blended Triangle, Ormaque, and Parallel ore varies annually from 96.7% to 97.0%.

Expectations for metallurgical recoveries from the lower Triangle zones (C6 through C10) are slightly lower, at 95%. This does not include the lower-grade Stockwork zone which is not considered in the current analysis.

Expectations for metallurgical recoveries from the Ormaque deposit are in line with the upper Triangle zones at 97%.

## 17.3 Water Balance

A high-level water balance is presented in Figure 17-2. The balance will change with the planned conversion of the spare pre-leach thickener to a tailings thickener in 2025, and then again with the addition of a paste backfill plant in 2026, as illustrated in Figure 17-3. Once the paste plant is in operation, all water removed from the tailings in the paste plant thickener and filter, as well as seal water used within the paste plant, will be returned to the Sigma mill.

The mill also requires an average of about 65 m<sup>3</sup>/h fresh water for reagent mixing, gland water, gravity concentrators, loaded and regenerated carbon screens as well as elution and carbon regeneration. The paste plant will also require around 15 m<sup>3</sup>/h fresh water for flocculant mixing, gland water, paste mixer cleaning and paste line flushing. Water from the Sigma underground mine will be used for this purpose. The Sigma mill is also connected to city water which will be used for sanitary purposes and safety showers and serves as back-up for fresh water.

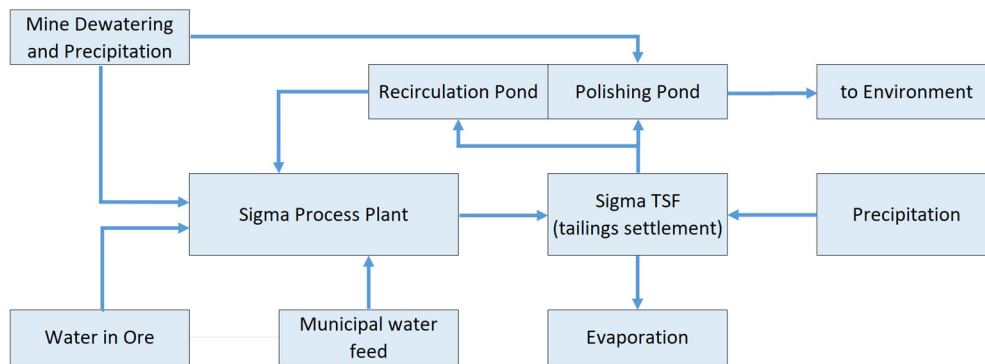

Figure 17-2: High-Level Mill Water Schematic (Eldorado 2024)

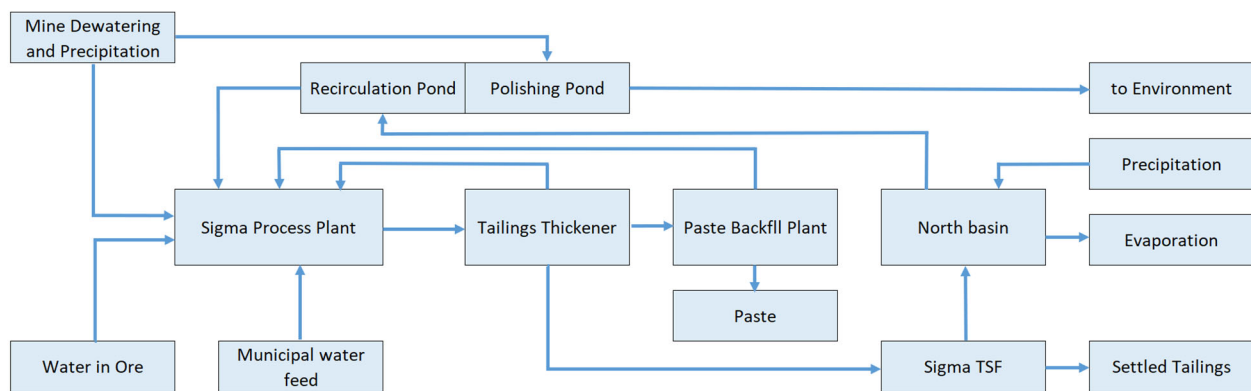

Figure 17-3: High-Level Mill Water Schematic – Future (Eldorado 2024)

## 17.4 Process Equipment

The major equipment required for the process operation is listed in Table 17-1 with their general characteristics.

Table 17-1: Major Equipment List

Equipment	Characteristics
<b>Crushing</b>	
Jaw Crusher	1120 × 870 mm, 260 kW
Cone Crusher	300 kW
Screen	2.4 × 6.0 m triple deck
<b>Grinding</b>	
KVS Ball Mill	3.51 m × 4.27 m, 750 kW
AC Rod Mill	2.74 m × 3.65 m, 300 kW
AC Ball Mill	3.66 × 4.27 m, 930 kW
Primary / Secondary Cyclones	25 cm cyclones
Trash Screen	1.8m × 4.9m, 30 kW
<b>Gravity Circuit</b>	

Equipment	Characteristics
Gravity Static Screens	1.2 m wide sieve bend (2)
Gravity Concentrators	50 cm dia. gravity concentrators (2)
Shaking Table	1.3 m W × 2.2 m L (1)
<b>Leaching and Carbon-in-Pulp</b>	
Pre-Leaching Thickeners	Two (2) 4.55 m D high-rate thickeners
Leach Tanks	11.5 m D × 11.5 m H, useful volume 1,015 m <sup>3</sup> (2 new tanks 2500 m <sup>3</sup> effective volume)
CIP Tanks	7.6 m D × 7.3 m H (1) and 6.7 m D × 5.5 m H (6)
Interstage Screens	4 m <sup>2</sup> interstage screens, 7.5 kW each (7)
Safety Screens	Two vibrating screens, 5.5 kW each
Cyanide Destruction	6.7 m D × 7.3 m H, useful volume 440 m <sup>3</sup>
<b>Carbon Circuit and Elution</b>	
Barren Carbon Dewatering Screen	Vibrating 1.2 × 2.4 m, 7.5 kW
Carbon Regeneration Kiln	400 kW electric heating capacity
Fine Carbon Filter-Press	30 m <sup>2</sup> filtration surface
Carbon Attrition Tank	1.5 m D × 1.8 m H
Loaded Carbon Screen	Vibrating 1.2' × 2.4', 7.5 kW
Acid Wash Column	6 m <sup>3</sup> capacity for 3t of carbon
Elution Columns	6 m <sup>3</sup> capacity for 3t of carbon
Heat Exchangers	One (1) shell-and-tube, Two (2) plate-and-frame
Barren Solution Heater	(To be replaced with gas-fired heater)
Electrowinning Cells	Two electrowinning cells
<b>Refinery</b>	
Mercury Retort System	0.3 m <sup>3</sup> retort
Refinery Filter-Press	N/A
Induction Furnace	75 kW heating capacity

## 17.5 Design Criteria

Table 17-2 presents the current design criteria for processing at the Sigma mill.

**Table 17-2: Design Criteria**

Criteria	Units	Value
<b>General</b>		
Mine Production per Day (dry tonnes)	tpd	2,600
Mill Availability	%	95
Gold Recovery	%	96
Crushing Plant Availability	%	75
Hourly Operating Plant Throughput	tpoh	110
<b>Crushing</b>		
Hours of Production per Day	h	12

Criteria	Units	Value
Jaw Crusher Closed Side Setting	mm	150
Crushing P <sub>80</sub>	mm	133
<b>Grinding</b>		
Average Grinding Power	kWh/t	25.7
Grinding P <sub>80</sub>	µm	40
<b>Gravity</b>		
Gold Gravity Recovery	%	14.6
<b>Leaching</b>		
Pulp Density	%	50
Number of Tanks		7
Total Residence Time	h	> 70
<b>Carbon-in-Pulp</b>		
Number of Tanks		7
Total Residence Time	h	>7
Carbon Concentration	g/L	20
<b>Elution and Carbon Regeneration</b>		
Elution Capacity (carbon)	t/d	3.6
Loaded Carbon Gold Grade	g/t	3,245
Barren Carbon Gold Grade	g/t	100
Elution Temperature	°C	142
Elution Pressure	kPa	450
<b>Cyanide Destruction</b>		
Effluent Cyanide Concentration (CN <sub>WAD</sub> )	mg/L	<1

## 17.6 Power Reagents and Consumables

### 17.6.1 Power

Total power consumption at the site is approximately 12.8 MW with the process operation currently consuming 4.9 MW. The electrical power currently supplied is sufficient for the processing requirements and future additions including the paste plant requiring approximately 1.3 MW to be supplied from an existing line.

Future power requirements for the paste backfill plant will be analyzed based on siting, sizing, and other design parameters and may require additional power infrastructure.

### 17.6.2 Reagents and Consumables

Reagent consumption rates are expected to remain at current rates. Current consumption rates of reagents and consumables are presented in

Table 17-3. Cement will be required for backfill (cemented paste) once the paste plant comes online and is discussed in Section 18.12.

Table 17-3: Consumption of Reagents and Consumables

Reagent or Consumable	Unit	Consumption
Grinding media (rod mill)	kg/t	0.25
Grinding media (primary ball mill)	kg/t	0.33
Grinding media (secondary ball mill)	kg/t	0.43
Sodium cyanide (100% NaCN)	kg/t	0.54
Lime (CaO)	kg/t	1.00
Flocculant	kg/t	0.25
Carbon	kg/t	0.07
Hydrochloric acid (HCl)	kg/t	0.15
Caustic soda (NaOH)	kg/t	0.20
Calcium chloride	L/t	1.00
Scale inhibitor	kg/t	0.09
Sodium metabisulphite (Na <sub>2</sub> S <sub>2</sub> O <sub>5</sub> )	kg/t	1.20
Copper sulphate (CuSO <sub>4</sub> .5H <sub>2</sub> O)	kg/t	0.25

## 17.7 Plant Personnel

The plant staffing levels will remain consistent with the current levels throughout the life of mine apart from the addition of four operating staff and four maintenance staff for paste plant operation. The list of plant personnel is provided in Table 17-4.

Table 17-4: Plant Personnel

Description	Number of Personnel
<b>Staff</b>	
Operations General Manager	1
Mill Superintendent	1
Metallurgist	1
Metallurgical Technician	3
Operations Supervisor	2
Mechanical Supervisor	1
Electrical Supervisor	1
Maintenance Supervisor	1
Surface Supervisor	1
Mechanical Planner	1
Reliability engineer	1
Subtotal Staff	14
<b>Operations</b>	
Grinding Operator	4
Solutions Operator	4
Crushing Operator	4
Reagents Operator	2
Loader Operator	4
Back-up Helper	4
Subtotal Operations	22
<b>Maintenance</b>	
Mechanic	8
Electrician	3
Carpenter	3
Subtotal Maintenance	14
<b>Total</b>	<b>50</b>

## 17.8 Plant Layout

The main building of the process plant contains most of the unit operations. The image shown in Figure 17-4 shows the process area, from top right to bottom left operational areas are crushing, ore storage (dome) main plant and leaching (tank farm) respectively.



Figure 17-4: Process Plant Aerial Photo (Google Earth 2023)

## 18 Project Infrastructure

### 18.1 Site Access and Logistics

The Lamaque Complex has been in commercial production since 2019 and is situated in an active mining district. Located on the eastern limits of Val-d'Or, the site benefits from direct access to a provincial highway with proximity to essential infrastructure and resources to support ongoing operations. Equipment and supplies are readily transported via paved roads to the Sigma mill and Ormaque project and over a well maintained gravel road directly to the Triangle mine. Both the mill and mine sites are free of logistical challenges and can accommodate heavy transport through the provincial infrastructure. Additionally, rail services and the Val-d'Or Airport (IATA airport code YVO) are nearby, further enhancing accessibility.

### 18.2 Site Infrastructure

The site has all necessary infrastructure in place to support current mining and processing operations. Early construction at the Triangle mine site was initiated in 2015 in preparation for an underground exploration program. Infrastructure for the Ormaque mine is planned to be built in two sectors, the areas adjacent to the regional exploration office core yard and northeast of the historic Lamaque tailing facilities. The Sigma mill, originally built in 1937, was refurbished in 2017 through 2018 prior to commercial production. The Lamaque Complex has the following infrastructure, either existing or planned.

- Triangle mine
  - mine dry and office complex
  - garage
  - warehouse
  - mine ventilation facilities
  - compressor house
  - waste rock stockpile
  - slurry plant and cement silo
  - core logging building
  - surface fuel station
- Future Ormaque mine
  - mine dry and office
  - garage (dome type)
  - outdoor laydown yard
  - waste rock stockpile
  - mine ventilation facilities (planned)
- Sigma mill
  - main process plant
  - covered crushed ore storage
  - crushing facility
  - warehouse
- Sigma-Triangle Decline
- Support infrastructure
  - regional administration office

- exploration office and core yard
- construction offices near Sigma mill
- Tailings storage facility (Sigma TSF)
- Site water management and collection ponds
- Paste plant (planned)

### 18.3 Site Development

Integra's acquisition of the Sigma-Lamaque Complex in 2014 provided the company with a permit for a 5,000 tpd milling complex and TSF (Sigma) in proximity of the Triangle mine. The mill capacity has been reduced to 2,500 tpd after the removal of a SAG mill by the previous owner. The Sigma-Lamaque Complex also included three portals giving access from underground to surface infrastructure, including the mechanical workshop, offices, mine dry, and equipment. The acquisition included all mining concessions and mineral claims on the past producing property.

Triangle infrastructure was put in place during the summer and fall of 2015 to develop an underground exploration ramp and conduct a bulk sampling program as proposed in the 2014 PEA.

Land clearing, road construction, and site preparation were carried out in the summer of 2015. A 25 kV power line was erected between the Sigma mill and Triangle mine surface facilities. Pipelines (two 6-inch HDPE pipes) were installed to transport water from the dewatering of the Triangle underground workings. The sites were connected to Val-d'Or's municipal water and sewage systems. The final connections to the electrical grid and the Val-d'Or water network were completed in 2016.

A portal was excavated to accommodate a ramp 5.1 m wide by 5.5 m high to access the Triangle mine.

In 2017, Eldorado acquired Integra and the Triangle site was expanded to support the future production phases. Modular buildings were added to increase dry capacity from 100 to 200 workers. Another expansion was completed in 2018 to increase capacity to 400 workers by adding extra modular buildings. A modular building to serve as technical services and administration offices was added in 2017 as well as other buildings to serve for health and safety, training, and surface personnel. During 2017, an expansion of the garage-warehouse building was completed to add two service bays, one wash bay, tripled warehouse capacity, and added office space for maintenance personnel. A dome building was added in 2018 to serve as a garage for underground transport vehicles to facilitate transport of personnel at shift change. During 2017, a temporary heating unit building was built over the escapeway at surface, heating intake air for underground ventilation. A buried natural gas supply line was installed to provide fuel. A permanent guardhouse was completed at Triangle in 2018. In 2019, the permanent mine ventilation and heating system was commissioned. Also in 2019, a multi-service building including an air compressor system and a cement plant were commissioned.

In 2018, a Certificate of Authorization was granted, allowing for the Sigma mill to operate at up to 5,000 tpd.

The Sigma mill refurbishment started in 2017 and was completed in late 2018 with commissioning and subsequent commercial production in 2019.

A new mine dry and office facility were constructed at the Triangle site to support mining operations and the complex was opened in October 2021 (Figure 18-1).

Excavation of a 2.5 km long decline (8.1 m wide × 5.1 m high) was completed in December 2021 between the Sigma pit crest (Figure 18-2) and the 400 Level at Triangle allowing for direct ore and waste haulage between the Triangle mine and the Sigma mill.



Figure 18-1: Triangle Mine Operation (Eldorado 2024)



Figure 18-2: Sigma Mill and Decline Portal (Eldorado 2024)

Temporary infrastructure was put in place at Ormaque during the spring of 2024 to develop an underground exploration ramp and conduct a bulk sampling program. Modular buildings provide a dry capacity for 100 workers. The existing modular construction office currently serves as space for technical services.

## **18.4 Local Infrastructure**

### **18.4.1 Housing**

Given the close proximity to Val-d'Or, no provisions have been considered necessary for workforce housing accommodations, or transportation arrangements for operations or construction activities.

### **18.4.2 Site Access Road**

The Lamaque Complex includes operations located on two sites, the Triangle mine operation and Sigma mill operation. The Sigma mill is located directly off Hwy 117, approximately 1.3 km east of Rue Saint Jacques on the eastern edge of Val-d'Or. The Triangle mining operations are east of the intersection of 7e Rue and Barrette Blvd. along the Goldex-Manitou access road, 3.6 km east of 7e Rue.

### **18.4.3 Surface Electrical Infrastructure, Distribution, and Consumption**

A 25 kV, 3-phase 18 MVA overhead line from Hydro-Québec provides electrical power to the operation. This line is currently feeding an outdoor substation providing power to Sigma and Triangle utilities.

The underground and mill activities are supplied by two dedicated outdoor substations with two redundant transformers and switchgear.

The mine requires power for additional ventilation and dewatering systems as development advances, and minor upgrades to the process plant are planned.

The plan for Ormaque mine ventilation, underground infrastructure, and the paste plant requires an estimated 4.9 MW of additional power. Use of an existing 25 kV, 3-phase 7 MVA overhead line is proposed.

### **18.4.4 First Aid and Emergency Services**

An active emergency response plan is in place and active for both sites.

Proximity to Val d'Or provides ready access to emergency services. Local police authorities, fire brigade, ambulance service, and hospital are, on average, 10 minutes away from the Sigma site and 15 minutes from the Triangle site. Each service has been contacted, notified, and documented as per the active ERP.

A mine rescue team is active and readily available on the Lamaque Complex at any given time.

Qualified first aid and first responders are always available on site.

## **18.5 Triangle Mine Site**

The following section describes the infrastructure in place at the Triangle mine site.

### **18.5.1 Administration Building and Mine Dry Complex**

The mine dry and administration building were put into service in October 2020. The permanent facility is a two-story building which includes offices for administration, technical and operational services, and dry facilities. It also houses the mine rescue facilities. The ground floor houses dry facilities for 411 employees,

(331 men and 80 women), with an area of 745 m<sup>2</sup>. The upper floor contains offices and additional meeting rooms.

### 18.5.2 Maintenance Shop and Warehouse

The surface maintenance shop is used to maintain all equipment used at the Triangle mine. With seven access doors, maintenance work on up to five pieces of production equipment can take place concurrently. The workshop is equipped with a wash bay, two 15-tonne cranes, a tool crib, an electrical workshop, and all the tools necessary for efficient maintenance of all the mobile equipment assets at Triangle. Warehouse and kitting areas are part of the building with approximately 200 m<sup>2</sup> of floor space.

### 18.5.3 Core Logging Building

A core logging building was commissioned in February 2019. It is sized to allow geology personnel to process more than 100,000 m of diamond drill core per year. It is equipped with offices, logging room, sample reception area, sawing and water management system, lavatories, and lunchroom. The building also houses a carpentry shop. Ormaque core may also be analysed in this facility.

### 18.5.4 Gatehouse and Parking

A security entrance gate controlling personnel, supplies and visitors accessing the Triangle mine site. Parking outside the gatehouse can accommodate 250 vehicles.

### 18.5.5 Underground Services

Underground services include the following items:

- Maintenance shop
- Fuel distribution
- Slick line for shotcrete delivery

The underground maintenance shop includes the following items:

- Heavy equipment service bay for two pieces of equipment with a 15-tonne overhead crane
- Wash Bay equipped with oil separator system
- Fire protection for the maintenance shop, oil / grease, and tire storage areas
- Garage fire door
- Electrical shop
- Warehouse
- Supervisor office
- Service bay for BEVs (battery swapping and maintenance)

### 18.5.6 Explosive and Detonator Storage

Explosives and detonators are stored underground in two separate permitted facilities located on Level 0425. The explosive storage room has a holding capacity of 135,000 kg and the detonator storage room has a holding capacity of 375,875 units. Permits were issued by the provincial police, Sureté du Québec, and are valid until June 30, 2025.

A small container (2.5 m by 12.0 m) located 100 m east of the Triangle laydown area is used to store explosive wrapping and boxes. A permitted burning facility for explosive wrapping and boxes is located on surface about 400 m west of Triangle and is used when required.

### **18.5.7 Fuel Storage and Delivery**

Both the Triangle mine and Sigma mill have diesel fuel storage systems consisting of dispensing units and 50,000-liter double walled tanks.

At Triangle diesel fuel is pumped underground using dedicated lined holes. It is delivered to a 4,500-litre double wall reservoir located in the fuel bay at the underground maintenance shop on level 0325. In the future, it will be pumped further down to a fuel bay located at level 0800. Explosion proof fuel dispensers are installed.

### **18.5.8 Contractor Dry and Offices**

The former trailers used for dry facilities and offices were kept in service and dedicated to contractor needs as required for the remaining LOM.

### **18.5.9 Triangle Mine Site Services**

The operation has all utilities in place to support existing and future operations. Ventilation and underground services are described in Section 16.

#### **18.5.9.1 Electrical Infrastructure**

A power line was constructed for the Sigma mill directly to the Triangle mine site and has sufficient capacity for existing and anticipated future operations.

#### **18.5.9.2 Potable Water and Sewage**

The Triangle mine site is connected to Val-d'Or municipal services. Municipal water is used for consumption and fire protection; sewage is discharged to the municipal system. The connection to the municipal systems is via 2.5 km private pipelines installed between Triangle and the Sigma mill site.

#### **18.5.9.3 Mine Service Water**

A clean water sump is in operation on Level 0135 (underground). The sump collects seepage water from the upper part of the Triangle development (Level 0070) close to the ventilation raises. The sump has a capacity of over 200 m<sup>3</sup> and water is pumped to the industrial water network to serve the mining operation. The water is 100% provided from underground operations and generates recycled water.

#### **18.5.9.4 Communication and IT**

The Triangle mine site is connected to the public telephone service and internet. A new VOIP telephone network was also installed.

The communication between buildings uses single mode fiber optic cable. To allow employees to have wireless access, a network access point (WI-FI Unifi AP Pro) is installed in each of the buildings to permit cellular and computer connections. Long Term Evolution (LTE) services are available on surface and underground.

The surface radio communication system is the same as underground with LTE. Specific channels are used on each different sites (Triangle mine, Sigma mill, future Ormaque mining operations).

## 18.6 Ormaque Mine - Infrastructure Additions

Additional underground and surface infrastructure are required to support mining at Ormaque. The plan is to reallocate existing surface infrastructure and install an additional dome for maintenance. An aerial photography of new and relocated infrastructure with the existing infrastructure is displayed in Figure 18-3.



**Figure 18-3: Ormaque Surface Infrastructure (Eldorado 2024)**

The infrastructure in place at the Triangle mine site will also support Ormaque mining operations. The following infrastructure will be utilized for Ormaque mining operation.

### 18.6.1 Administration Building and Mine Dry Complex

The mine dry will be located in a new trailer and a previously used dry relocated to site. The main function of the facility is to accommodate mine operations personnel and provide an area for showering and changing into and out of work clothing.

The building will include the following areas:

- Dry areas for men and women with showers, sinks, toilets, urinals, and baskets.
- Lunchroom with kitchenette and janitor's closet.
- Planning and training / meeting room capable of accommodating 60 people.

### **18.6.2 Maintenance Shop and Warehouse**

A surface maintenance shop in a dome is planned for light equipment services. Fleet maintenance is planned to be completed at Triangle 0325 garage facilities. Site active warehouses and storage areas will also be used for Ormaque.

### **18.6.3 Gatehouse and Parking**

The Sigma mill security entrance gate will also control Ormaque personnel, supplies, and visitors. A dedicated parking lot will be added for Ormaque workers.

### **18.6.4 Underground Services**

Underground services include two lean maintenance workshops that are planned for Level 0300 and 0600. They will include the following:

- Wash Bay equipped with oil separator system
- Fire protection for the maintenance shop, oil / grease, and tire storage areas
- Garage fire door
- Expandable items Warehouse
- Supervisor office

### **18.6.5 Explosive and Detonators Storage**

Explosives and detonator storage facilities located in Triangle on Level 0425 will be used at the beginning of the project. Dedicated Ormaque explosives and detonator storage facilities are planned for construction on Level 0405.

### **18.6.6 Fuel Storage and Delivery**

Diesel fuel is stored on the eastern edge of the Sigma crusher ore pad in a 50,000-liter double-walled tank. Mine equipment that has access to surface fuel facilities will fuel on surface. A dedicated fuel and lube vehicle is planned for the remainder of the fleet.

### **18.6.7 Contractor Dry and Offices**

The trailers installed as contractors' dry facility and offices for the sampling program will be kept in service and dedicated to contractor needs for the remaining LOM.

### **18.6.8 Ormaque Mine Site Services**

The operation has all utilities in place to support existing and future operations.

#### **18.6.8.1 Electrical Infrastructure**

A power line was constructed from the Sigma mill directly to the Triangle mine site and has sufficient capacity for existing and anticipated Triangle future operations.

#### **18.6.8.2 Communication and IT**

The Ormaque mine site is connected to the public telephone service and internet.

The communication services described in 18.5.9.4 will be expanded to support the Ormaque mine.

### 18.6.8.3 Potable Water and Sewage

The Ormaque mine site is connected to Val-d'Or municipal services for potable water and sewage systems via the Sigma mill.

### 18.6.8.4 Mine Service Water

A water basin will be built to collect seepage and reuse water from diamond drill holes in GEX-0090 Ormaque zone. The basin will have the capacity to supply the service water requirements for Ormaque mining operations.

### 18.6.8.5 Dewatering

The mine dewatering network, shown in Figure 18-4, will consist of pocket sumps located on each level's lowest point to collect drainage water. They are small shallow excavations that can accommodate a submersible pump. Water will then be pumped in a pipe to the level temporary sump. From the level sump, it will be pumped to larger permanent pumping stations. Water will be pumped in cascade from one permanent pumping station to the one above until reaching surface. The system will be designed to handle dirty water.

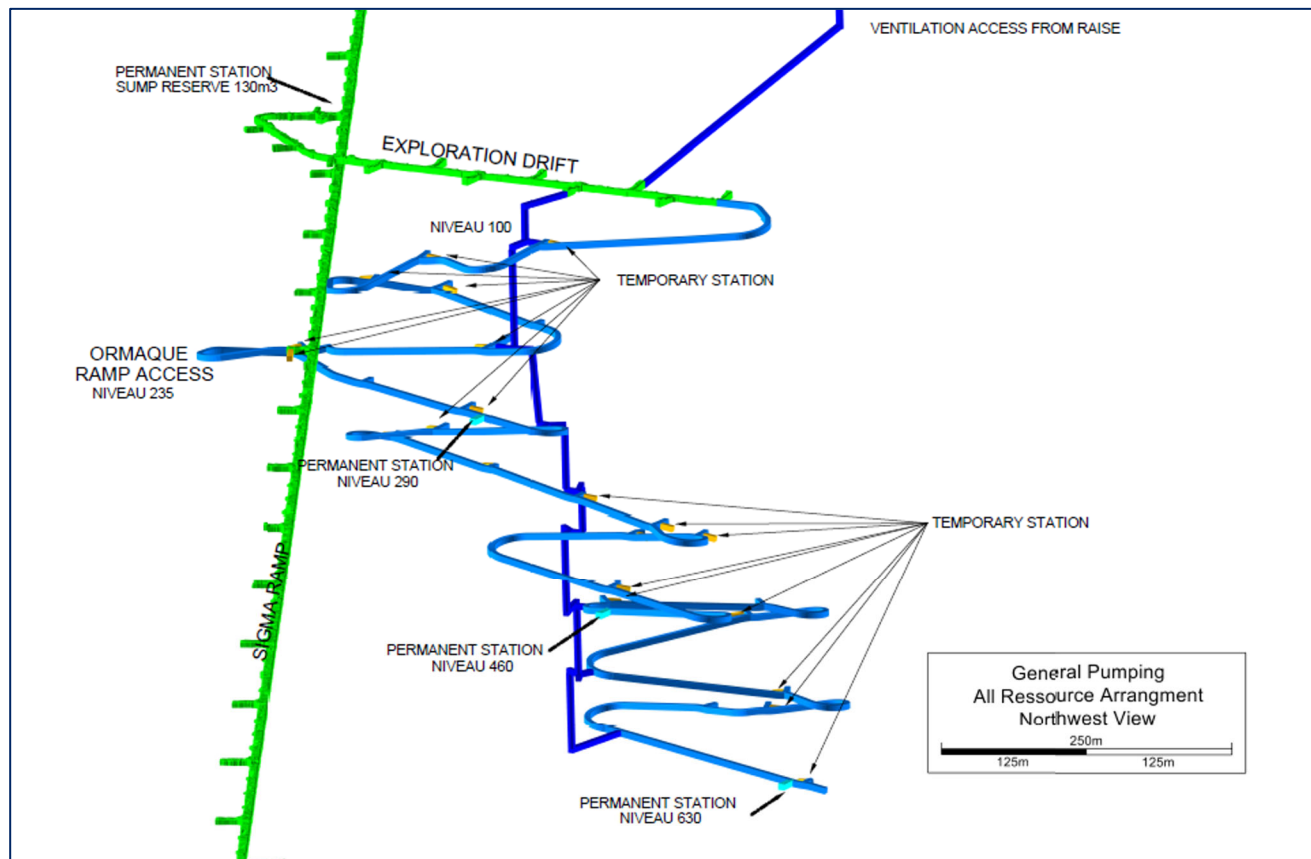

Figure 18-4: Dewatering System Network (Eldorado 2024)

### 18.6.8.6 Main Ventilation Network

The Ormaque deposit will possess an independent main ventilation network. A dedicated 5.1 m raisebored FAR will be drilled from surface. A natural gas burner and E-house will be installed on surface. The two

primary fans will be installed underground in a parallel configuration. The network will follow mine development as shown in Figure 18-5. Exhaust will be directed out the Ormaque ramp.

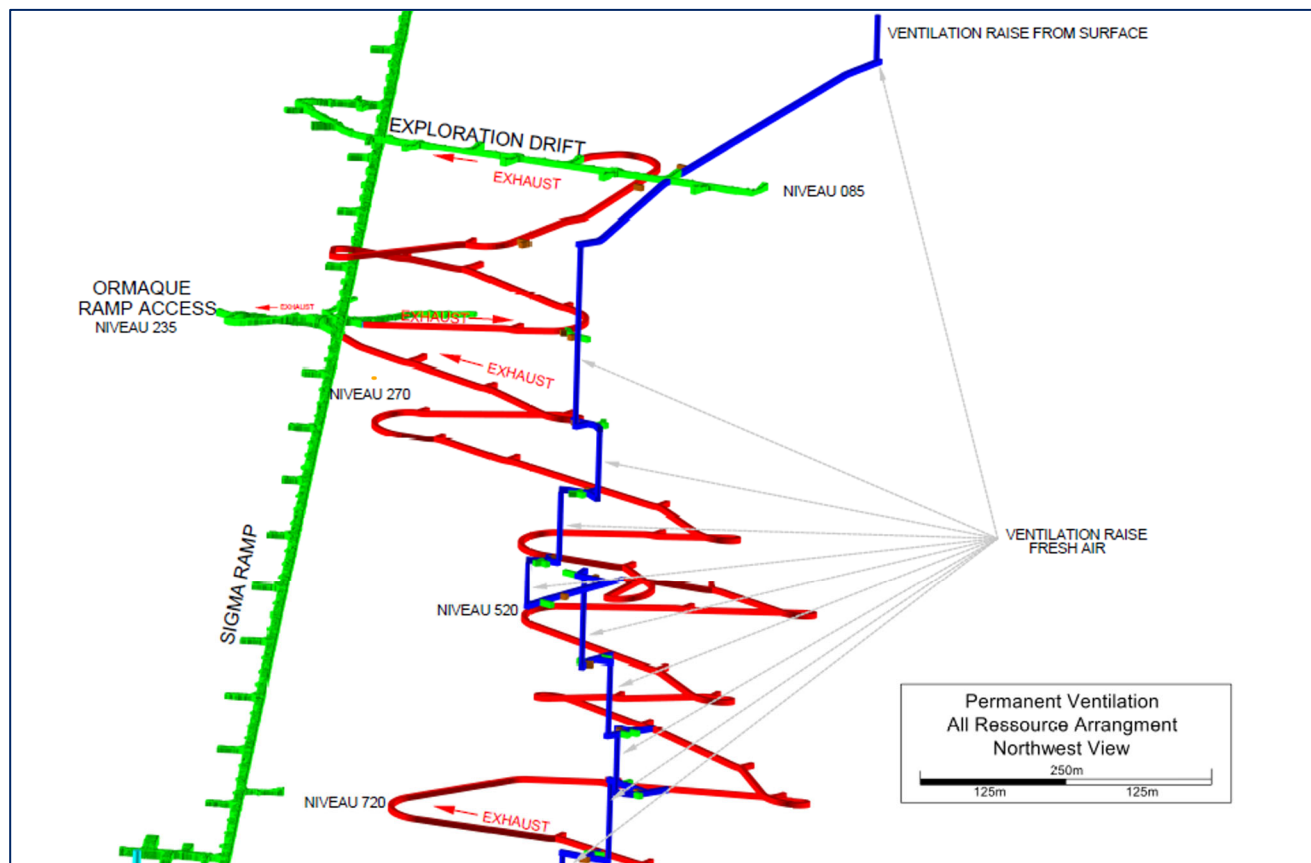

Figure 18-5: Ormaque Main Ventilation Network (Eldorado 2024)

## 18.7 Sigma Mill Complex

### 18.7.1 Process Plant

Plant refurbishing work was completed in 2018 to bring the plant to a level suitable for commissioning and continuous operation. Recently completed upgrades, now support milling operations of up to 2,500 tpd. The plant unit operations are described in Section 17 of the report.

#### 18.7.1.1 Plant Equipment Upgrades

In 2020, a dome was added above the coarse ore stockpile to reduce freezing by keeping snow and rain off the stockpile. The dome has also reduced dust during ore handling.

There are two leach tanks that were added (one in 2020 and one in 2021).

### 18.7.2 Sigma Mill Site Services

The Sigma mill operation has all utilities in place to support existing and planned future operations.

### 18.7.2.1 Electrical Infrastructure

The plant has all the existing infrastructure to support milling operations at a rate of 2,500 tpd.

The current power demand is estimated at 11 MW (11.6 MVA) based on operational data that includes Triangle mine operations.

### 18.7.2.2 Instrumentation

Instrumentation was fully replaced during the plant refurbishment and is augmented as required to support operations.

### 18.7.2.3 Communication and IT

The Sigma mill complex is connected to the public telephone service and internet. VOIP telephone network is installed at the Sigma mill.

The communication between buildings uses single mode optic fiber cable. To allow employees to have wireless access and to permit cellular and computer connections, a network access point (WI-FI Unifi AP Pro) is installed in each of the buildings. LTE services are available on surface.

A surface radio system consists primarily of channels with local short distance coverage or extended coverage. The following channels are planned for the site.

- Security / Emergency
- Surface Operations
- General and Maintenance (mechanical / electrical / housekeeping / etc.)

### 18.7.2.4 Potable Water and Sewage

The Sigma mill complex is connected to Val-d'Or municipal services for potable water, fire protection, and sewage.

### 18.7.2.5 Warehouse

A new 640 m<sup>2</sup> warehouse was constructed at the Sigma mill in 2023 and supports process operations.

### 18.7.2.6 Gatehouses and Parking

There is an entrance gate controlling personnel, supplies, and visitors accessing the Sigma mill. Security personal monitors all traffic entering the site. Parking can accommodate 200 personal vehicles and is directly accessed from Hwy 117.

## 18.8 Support Infrastructure

### 18.8.1 Regional Administration Office

The regional office was relocated to a leased building on the south side of Hwy 117, approximately 500 m east of the entrance to Sigma mill. The building is a two-story building with a total floor area of 1,900 m<sup>2</sup>.

### 18.8.2 Exploration Core Yard and Office

The exploration core yard is located on the south side of Hwy 117, approximately 700 m east of the entrance to Sigma mill. The core yard is approximately 24,000 m<sup>2</sup> with indoor facilities for core preparation and logging. Ormaque core may be analysed in this facility.

### 18.8.3 Construction Offices

The construction office is located 350 m east from the Sigma mill in an 800 m<sup>2</sup> prefabricated complex that was recently updated. It houses the construction and the environmental department supporting operations.

## 18.9 Material Stockpiling

The Lamaque Complex has the following six stockpiles on the site.

- Triangle mine waste rock pile (located beside the Triangle mine surface facilities)
- Future Ormaque mine waste rock pile (located east of Sigma TSF)
- Sigma waste rock pile (east of Sigma east)
- ROM stockpile (near the crushing operation)
- Mineralized Material Stockpile (mined Ormaque material near the crushing operation)
- Overburden pile (organic material east of Sigma TSF)

### 18.9.1 Waste Stockpile

Waste stockpiles serve as permanent storage infrastructure for the waste rock extracted from the underground mines. The Triangle waste pile is located close to the Triangle portal to limit transport distance. Stockpiling waste rock at the existing Sigma waste rock stockpile at the east end of the Sigma tailings management facility is also possible.

The waste stockpiles are built, permitted and are already in use. The Triangle stockpile covers an area of 52,000 m<sup>2</sup> for a total capacity of 400,000 m<sup>3</sup>. When the Triangle stockpile reaches capacity, surplus waste rock will be trucked through the ramp to the Sigma waste rock stockpile which can receive an additional 100,000 m<sup>3</sup>.

A dedicated Ormaque waste stockpile, including a water basin and diversion channelling, is planned east of the Sigma TSF with a capacity of 600,000 m<sup>3</sup>. Construction is planned to begin in 2025 with four cells being constructed over subsequent years as shown in Figure 18-6.

The stockpiled waste rock will also provide material for underground ramp roadbed construction, TSF raises, and various construction activities on surface.

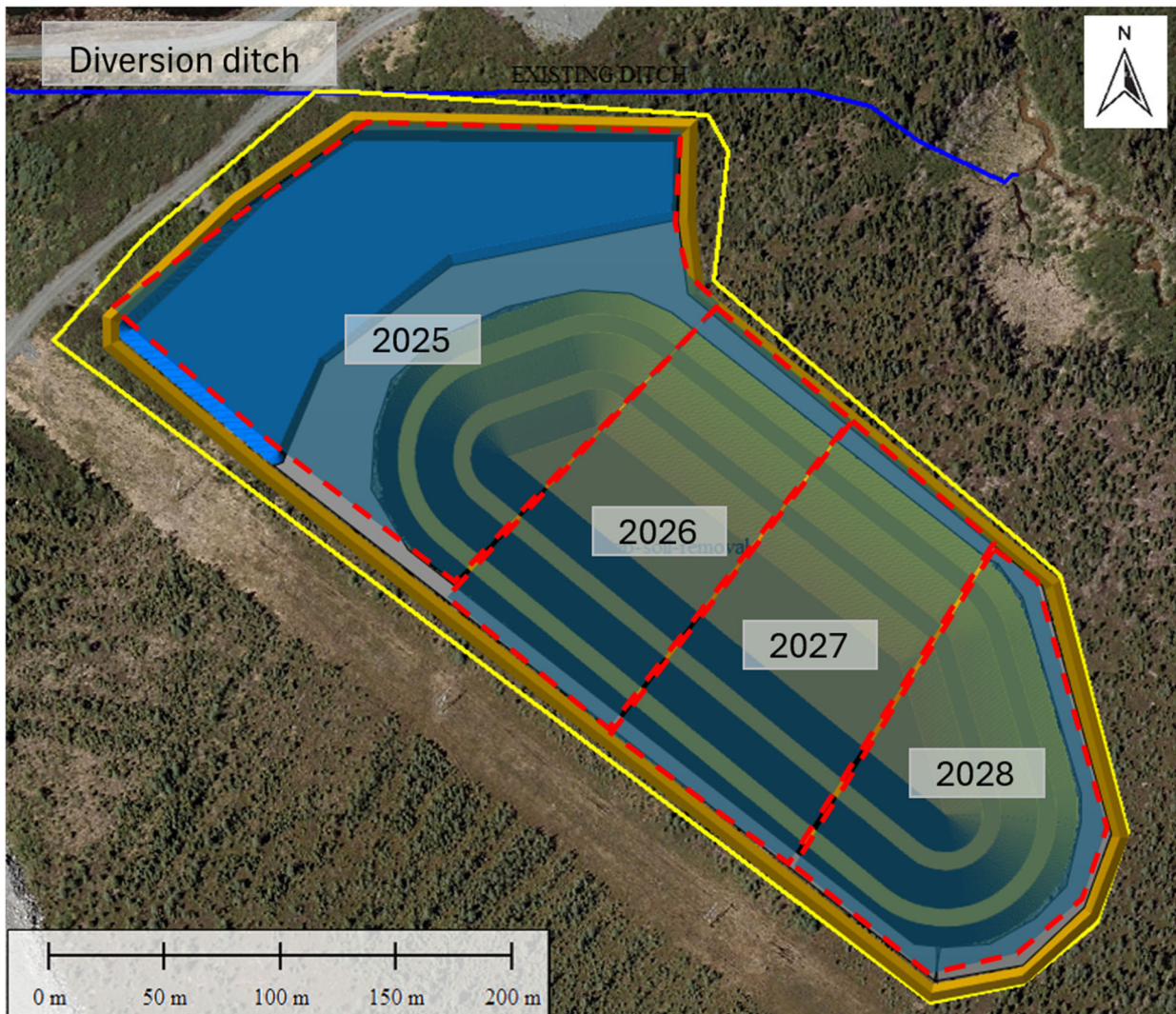

Figure 18-6: Ormaque Waste Rock – Planned (Eldorado 2024)

### 18.9.2 Run of Mine and Mineralized Material Stockpiles

In front of the primary crusher, an area of approximately 8,000 m<sup>2</sup> is available for stockpiling. Currently, two ore stockpiles are in use for Triangle ore and the Ormaque bulk sampling campaign. Volumes at the end of 2024 are described in Section 1.

An additional 23,000 m<sup>2</sup> is available for temporary waste rock storage in an area adjacent to the run of mine stockpile 460 m from the decline portal. Currently waste rock is classified for use in construction and road maintenance.

### 18.9.3 Overburden Stockpiles

An overburden stockpile is in operation at the Triangle site 500 m west of the portal access. The overburden material will serve for reclamation purposes at the end of the mining operation. A second stockpile is located 50 m south of the mill at the Sigma TSF.

## 18.10 Tailings Strategy

The current reserve plan requires approximately 5.92 Mt of tailings storage capacity. The Sigma mill pumps slurried tailings to the Sigma Tailings Storage Facilities (TSF). The Sigma TSF has approximately 2.86 Mt of capacity remaining once all phases are completed.

Construction of a paste plant is planned to start in 2025, with commissioning in the later half of 2026, to deliver cemented paste to the Ormaque and Triangle as backfill. Tailings volume in paste will account for approximately 2.06 Mt of tailings.

### 18.10.1 Sigma TSF

The Sigma TSF was refurbished and has been the tailings storage facility since operations commenced at the Lamaque Complex in 2019. The impoundment is located north of the Sigma mill, immediately north of the historic Sigma open pit and the CN railway. The tailings impoundment consists of four cells: B-1, B-2, B-4, and B-9. The main structures include the following items.

- West dyke
- South dyke
- North dyke
- East dyke
- Median dykes 1, 2, and 3
- Operational / Emergency Spillways
- Peripheral Ditches
- Recirculation Pond and a Polishing Pond

The dykes for the tailings impoundment were built and raised periodically with tailings. At the cessation of mining operations by Century Mining Corporation, tailings deposition was within cells B-1 and B-2, while the B-4 and B-9 cells were used only for storage of excess water. No tailings were deposited within the tailings impoundment from May 2012 to December 2018.

There were three dyke raises carried out between 2018 and 2021 to increase the storage capacity for tailings and water management as well as to stabilize the infrastructure up to current stability standards. The raises are detailed as follows.

- Phase 1 constructed in 2018: Raising of cell B-2 from elevation 318.5 m to 320 m for additional tailings capacity and berm construction for the TSF to stabilize for static loading
- Phase 2 constructed in 2019: Raising of cell B-1 and B-2 from elevation 320 m to 322 m for additional tailings capacity and berm construction for the TSF to stabilize for seismic loading
- Phase 3 constructed in 2021: Raising of cell B-4 and B-9 from elevation 320 m to 321.5 m for additional water management capacity

The tailings management strategy for the Sigma TSF was optimized in 2021 to increase its storage capacity, allowing the continuity of the operations beyond 2022. Three additional phases (phase 4, 5, and 6) were designed to extend the life of the tailings impoundment. Two phases have been implemented, Phase 4 completed in 2022, and Phase 6 completed in 2024, these bring the service life of the Sigma TSF until end of 2025.

- Phase 4 constructed in 2022: Raising of cell B-1 and B-2 from elevation 322 m to 323.5 m for additional tailings storage capacity
- Phase 6 constructed in 2023 and 2024: Raising of cell B-4 and B-9 from elevation 321.5 m to 323.5 m for additional water and tailings storage capacity

Phase 5 is the addition of a new water basin (the North Basin) planned for 2025 and 2026 and shown in Figure 18-7. This water basin was proposed to be built directly north of the Sigma TSF to contain the Design Flood defined in Directive 019 without spillage to the environment. This basin would extend the life of the Sigma TSF by removing the surface ponds and allowing for additional tailings capacity at B4 and B9, while reducing the risks associated with tailings and water management by managing water outside of the tailings impoundment facility. With the reduction in water storage requirements on the TSF additional storage capacity can be added providing two more years of service to the TSF, sufficient for operations to the end of 2027. The North Basin will be divided into two smaller basins (BN1 and BN2) for passive batch treatment of contact water through natural degradation and pH control.

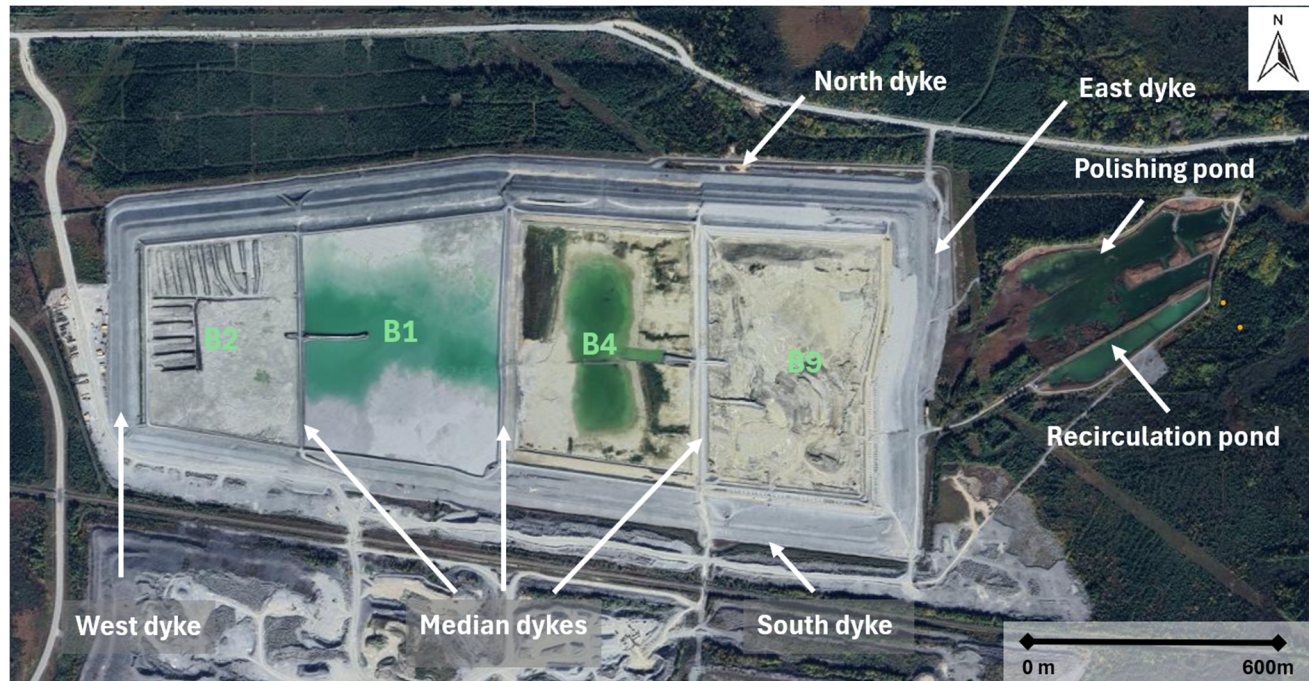

**Figure 18-7: View of the existing Sigma Tailings Storage Facility (Eldorado 2024)**

Phase 7 is planned as an additional raising of cell B-4 and B-9 from elevation 323.5 m to 325 m for additional tailings storage capacity of 1.5 Mt of tailings Figure 18-8.

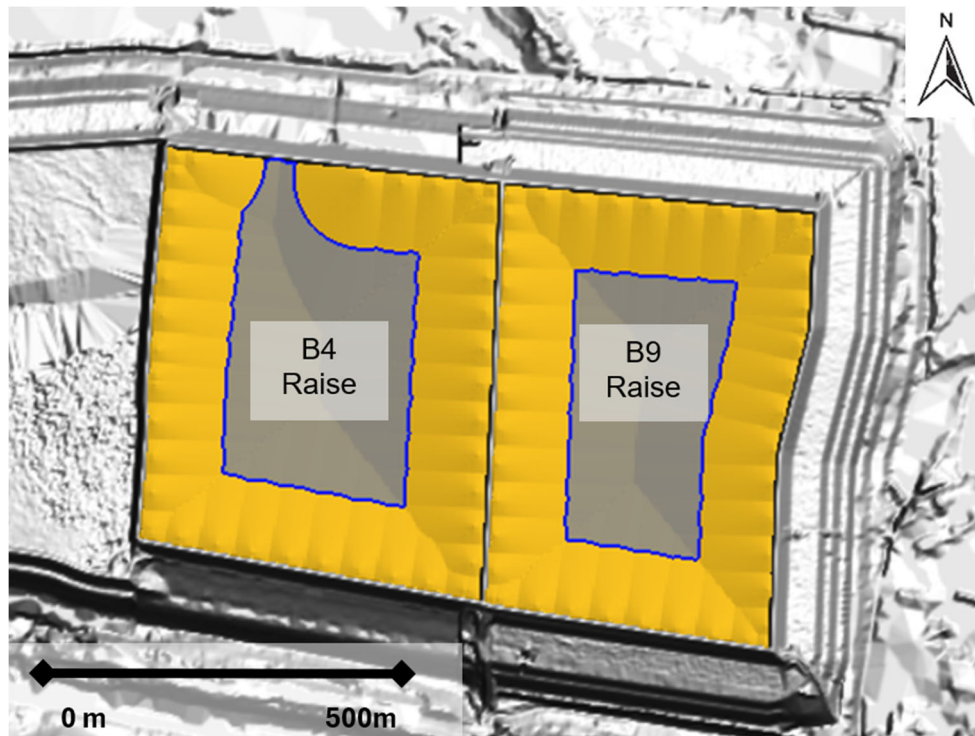

Figure 18-8: Sigma Tailings Storage Facility Phase 7 (Eldorado 2024)

### 18.10.2 Sigma TSF Progressive Closure

Progressive closure was evaluated to reduce surface drainage from the watershed of the Sigma TSF. As part of the current plan, the cells of the Sigma TSF will be closed, once full, to reduce site contact water storage requirements. The following sequence was projected:

- Cell B1 closure in 2025
- Cell B2 closure in 2026
- Cell B9 closure in 2028
- Cell B4 closure beyond 2029

Initially the North Basin was designed with a storage capacity of 1 Mm<sup>3</sup>. Considering the progressive closure of the cells and the residual water storage capacity from 2025 to 2028, the required volume for the Design Flood was reduced significantly (30% to 40% reduction). The storage capacity of the North Basin was reduced to approximately 0.6 Mm<sup>3</sup>, shown in Figure 18-9.

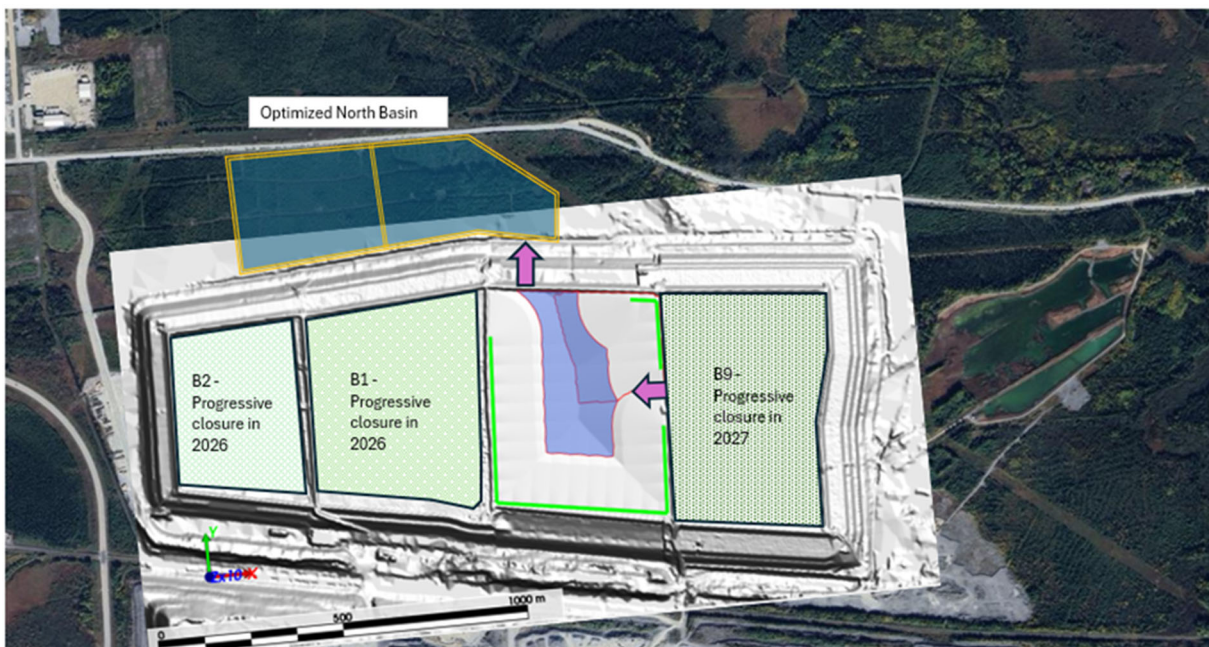

Figure 18-9: View of the existing Sigma Tailings Storage Facility at Completion (Eldorado 2024)

### 18.10.3 Historic Lamaque Tailings Impoundment

The Lamaque TSF, (also known as the historic Lamaque TSF) operated between 1934 and 1989 is located East of the town of Val d'Or, Québec and is surrounded by wetlands and fish habitat. The tailings are contained by four peripheral dykes (North, South, East, and West) with an average height between 4 m to 10 m. Based on past geotechnical investigations, the dykes are believed to have been built using sand and gravel and raised by the upstream method. The downstream slopes of the dykes, covered in vegetation, are relatively steep, exhibiting an average slope of 1.5H:1V. The dykes are classified between "Significant" to "Very High." The Lamaque TSF is currently classified as post-closure with the Ministry of Natural Resources and Forest, which is still under the environmental responsibility of Teck Resources but in "care and maintenance" by EGQ through private agreements signed with Teck.

The general surface has a low vegetation cover over a majority of tailings. Inside the TSF the surface slopes toward the south-east side with the supernatant pond against the east dyke. A series of internal ditches help to divert surface run-off toward the pond. Two spillways (operational and emergency) are located on the south-east corner, allowing surface run-off to discharge into a stream located at the toe of the TSF (stream 163). This is one of two streams classified as fish habitats located immediately at the toe of the dykes. The streams join and the main stream 163 flows toward the north, crossing Hwy 117, and continues to flow north discharging into Lake Langlade.

A main north-south gravel road was constructed from the Triangle mining operations towards the Sigma mill for services including power, natural gas, internet access, and water from the mill to the Triangle mining operation. The Ormaque deposit and Sigma-Triangle decline are located directly underneath the TSF. EGQ also built a network of gravel roads over the surface of the TSF to access drill pads to facilitate exploration; EGQ has been actively drilling to the deposits below as the TSF sits above the Ormaque and Parallel deposits and with the decline between the Triangle mine and the Sigma mill. On the surface a historic mine opening exists towards the south-east. The current arrangement is shown in Figure 18-10.

The TSF is regularly inspected and receives ongoing maintenance. The capital cost estimates for both cases includes budgets for additional buttressing the dams sections to improve factors of safety.

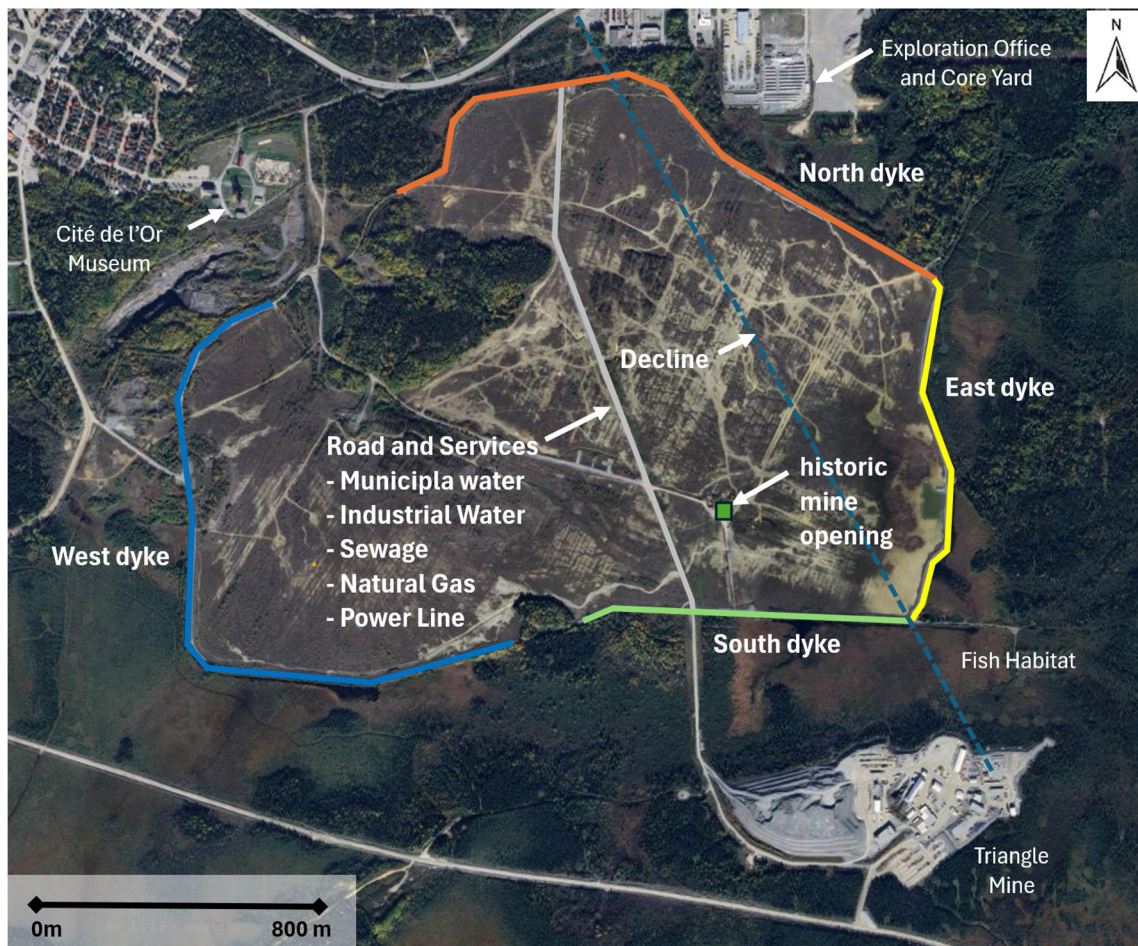

Figure 18-10: Lamaque TSF – Current Site Plan View (Eldorado 2024)

## 18.11 Water Management

Currently water from the Triangle mine (infiltration and runoff water), as well as the mine drainage water, is sent to a polishing pond before discharge. Runoff water from historic Lamaque pit is managed in an underground mine stope. The water from historic Sigma-Lamaque underground mine stopes, as in previous water management strategies, is transferred by pumping to the recirculation basin for the milling process, or to the polishing pond to be discharged to the environment.

Water is currently stored in the following three locations on site:

- Sigma TSF cell basins
- Reticulation Pond
- Polishing Pond

To reduce water storage requirements on the Sigma TSF new North Basin, Phase 5 described in Section 18.10.1, replacing Sigma TSF cell basin storage requirements.

Contaminated water will be managed/treated in the new North Basin for three main contaminants: total suspended solids (TSS), cyanide, and ammonia. Expansion to the cyanide destruction circuit will provide additional residence time and contribute to lower  $CN_{WAD}$  concentrations in the discharge.

Water would be transferred by pumping to the recirculation basin and from there to the mill, or to the polishing pond for water quality control and monitoring before being released to the environment. Water inside the cells, as mentioned, will be maintained as low as possible. The objectives are to reduce / minimize the risk of overflowing during operations, as well as to mitigate impacts in the unlikely event of a dyke failure, and lowering risks by drastically reducing water storage on the surface of the Sigma TSF.

A summary of the water management system is presented in Figure 18-11 in a form of a flow diagram.

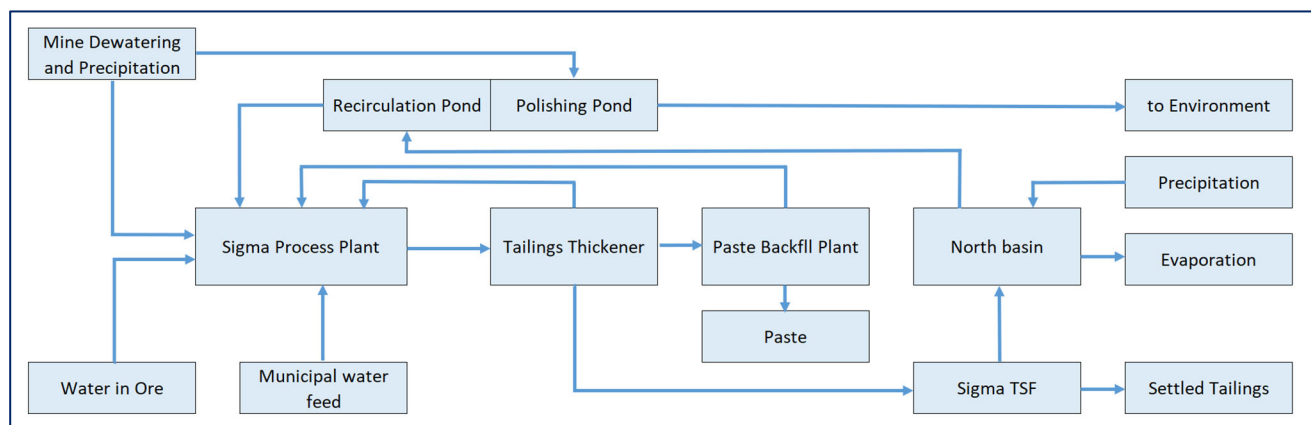

**Figure 18-11: Overall Water Management Schematic - Future State**

As the Lamaque TSF comes online there will be an additional collection/settling pond on the surface. A portion of the water from the pond will be transferred to the North Basin, similarly to the Sigma TSF basin, as the Sigma collection area storage requirements are reduced during progressive closure. Redundant pumps and energy / electricity services will be installed to reduce risks.

### 18.11.1 Water Treatment (Future)

Québec regulations regarding effluent discharge quality are expected to be updated. To meet the expected future guidelines, a water treatment plant has been included in mid-term planning for the operation, focused on removing ammonia from the underground mine dewatering flow. Ammonia is the most significant contaminant with respect to overall effluent water quality.

A high-level concept for water treatment has been evaluated consisting of a moving bed biofilm reactor (MBBR) for removal of up to 50 mg/L of ammonia at a nominal capacity of 100 m<sup>3</sup>/hr, as illustrated in Figure 18-12. This same water treatment can be adapted to treat other contaminants if there are any changes in the geochemistry of the ore and waste rock of the new Ormaque deposit which is being studied.

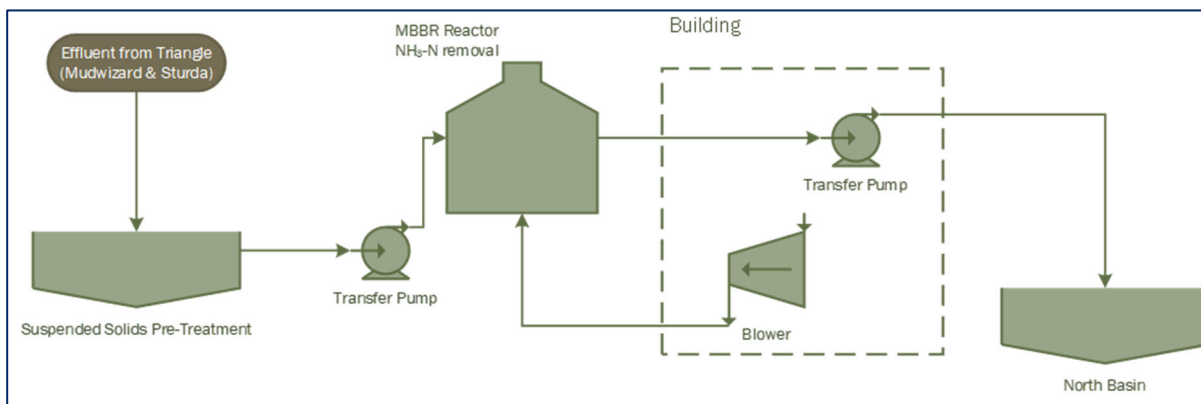

**Figure 18-12: Conceptual Water Treatment for Ammonia Removal from Mine Dewatering (Eldorado 2024)**

## 18.12 Paste Backfill Plant

Construction of a paste backfill plant will improve mine backfill options and productivity. Actual dedicated backfill mining fleet requirements will be reduced. This in turn will reduce ventilation/heating requirements to support future underground operations. The paste backfill plant would also allow approximately 50% of the tailings to be disposed of underground and increase the life of future TSFs.

The paste plant will use Sigma mill tailings that will be dewatered, mixed with cement, and pumped to Ormaque and Triangle. Tailings not used as paste or when the plant is not operating will be pumped as slurry tails to the Sigma TSF.

Initial laboratory test work for paste was carried out on tailings samples in early 2018 to determine the amenability to liquid-solid separation and to determine a preliminary paste recipe for the surface disposal. Studies in 2021 confirmed the results and looked at additional paste recipes.

Based on available results, the tailings are amenable for the thickening process. The tailings have a poor response to vacuum filtration, due to the fine particle size distribution, so pressure filtration is the selected dewatering solution.

The paste backfill plant is composed of thickening, filtration, mixing and paste pumping areas. The plant is being designed to take up to 54% of the Sigma mill tailings stream. The major equipment includes filter press, paste mixer, and positive displacement pump(s) that will be able to deliver the paste for deposition in underground stopes.

### 18.12.1 Paste Plant Design Criteria

The paste plant is designed to use 1,400 tpd of tailings from the Sigma mill with cement binder addition estimated at 3.5%, Table 18 2 presents the main design criteria.

**Table 18-1: Paste Plant Design Criteria Summary**

Parameter	Unit	Value
Tailings Production	t/d	1,400
Solid Content	%	71
Binder Content (average)	%	3.5
Binder Type		Slag / cement

Parameter	Unit	Value
Paste Production (instantaneous)	m <sup>3</sup> /h	46

## 18.12.2 Paste Plant Process Description

Detoxified tailings will be used to produce the paste backfill. Since the design of the paste backfill plant is dependent on the material properties of the tailings, preliminary testing was conducted to determine the potential paste recipe for underground disposal.

The paste backfill tonnage was determined and calculated based on the utilization of all tailings produced by the process plant at an average incoming dry solids rate of 1,400 tonnes per day.

The tailings streams will feed the paste plant thickener (existing mill spare thickener) from the cyanide destruction tank. The tailings slurry is characterized by a solids content of 46.5%, a solids specific gravity of 2.80, and a particle size distribution of 80% passing 60 microns.

The thickener will increase the tails solid content from approximately 46.5% to 60%. The thickened tailings will be pumped by a pipeline to an agitated filter feed tank at the paste plant location to manage fluctuating flows and brief stoppages. The agitation in the tank will enable homogenization prior to filtration.

The tailings will be pumped from the feed filter tank via a filter feed pump. A second filter feed pump will be installed as a backup for the filter.

Filtration will increase the slurry density from 60% solids w/w to 82%. Filter press parameters were defined based on filtration test results.

Filter cake will be discharged from the filter plates and clean process water used to wash the filter cloths. The cloth wash and the core wash water will be provided from the Sigma stope water pipeline. All water used for core and cloth wash will be returned to the filtrate tank and sent back to the tailings pumpbox. The filtrate tank has a risk of solids deposition. An agitator will be installed to keep the solids in suspension.

Filter cakes from the filter press are discharged onto a belt conveyor to fill a cake hopper. A belt conveyor will continuously extract the cake from the hopper to feed the paste mixer.

Cement will be stored in a silo adjacent to the paste backfill plant. The silo will be equipped with a dust collector as well as a screw feeder conveyor discharging onto a weigh belt conveyor to control the binder addition. The binder will drop and blend with slurry into a vortex mixer. An additional dust collector will be installed close to the weigh belt conveyors and the mixing tank chute for dust control.

A twin shaft paste mixer will be used to combine the various constituents into the final paste product. The filtered tailings cakes will be mixed with the premixed cement and slurry so that the discharge from the mixer is a consistent paste slump at a desired 70% to 73% solids depending on the paste recipe. The paste mixer will be equipped with a high-pressure wash unit.

The paste will then be discharged from the paste mixer through a paste hopper. A positive displacement pump will be installed, to pump the paste to the mine. Two boreholes connected to a common distribution network will be drilled from the paste plant to the decline and then to the mining stopes.

Figure 18-13 presents a simplified flowsheet.

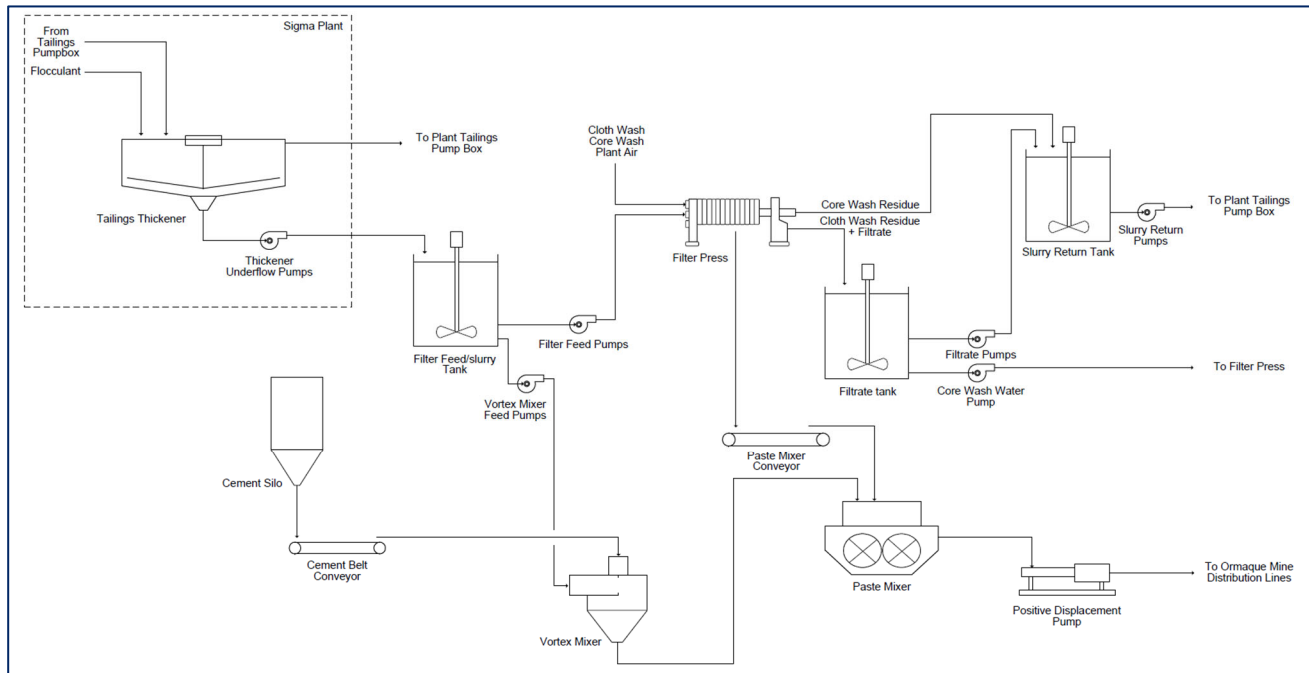

**Figure 18-13: Paste Plant Simplified Flowsheet (Eldorado 2024)**

Fresh water requirements (i.e., gland seal water, flocculant preparation, paste mixer wash water) will be provided by the underground mine dewatering process. A freshwater tank will be installed at the paste backfill plant to supply fresh water to all systems.

The paste plant process water will be used for core and cloth wash, piping network cleaning and paste water makeup. The filtrate from press filtration will be pumped into the tailing pump box.

### 18.12.2.1 Paste Plant Electrical Distribution

The power demand for paste backfill plant has been estimated at about 1,900 kW (1,950 kVA), with 750 kW (750 kVA) required on emergency power source.

To meet the anticipated electrical power needs of the paste backfill plant project, it is proposed to install one 3,500 kVA electrical transformer (25 kV to 600 V) inside one of two electrical rooms in the paste backfill plant building. Power will come from a new 25kV hydro Québec connection at the Highway 117.

### 18.12.2.2 Paste Plant Automation and Instrumentation

A control room is planned to be installed inside the paste backfill plant building.

A fiber optic link with the concentrator will be installed beside the pipeline to allow availability at the paste backfill plant for automation (PLC, HMI), fire alarm, cameras, corporative, and phone networks.

A new communication control cabinet will be installed in the second electrical room.

The control system is designed with the main PLC cabinet, located inside the second electrical room. This PLC will control all instruments inside the building. All instrumentation models will be the same as used in the concentrator.

### 18.12.2.3 Paste Backfill Reticulation

A reticulation network has been developed and costed for the Technical Report. As the mine design is further developed the system will be optimized. The current proposed Ormaque paste backfill reticulation network is shown in Figure 18-14.

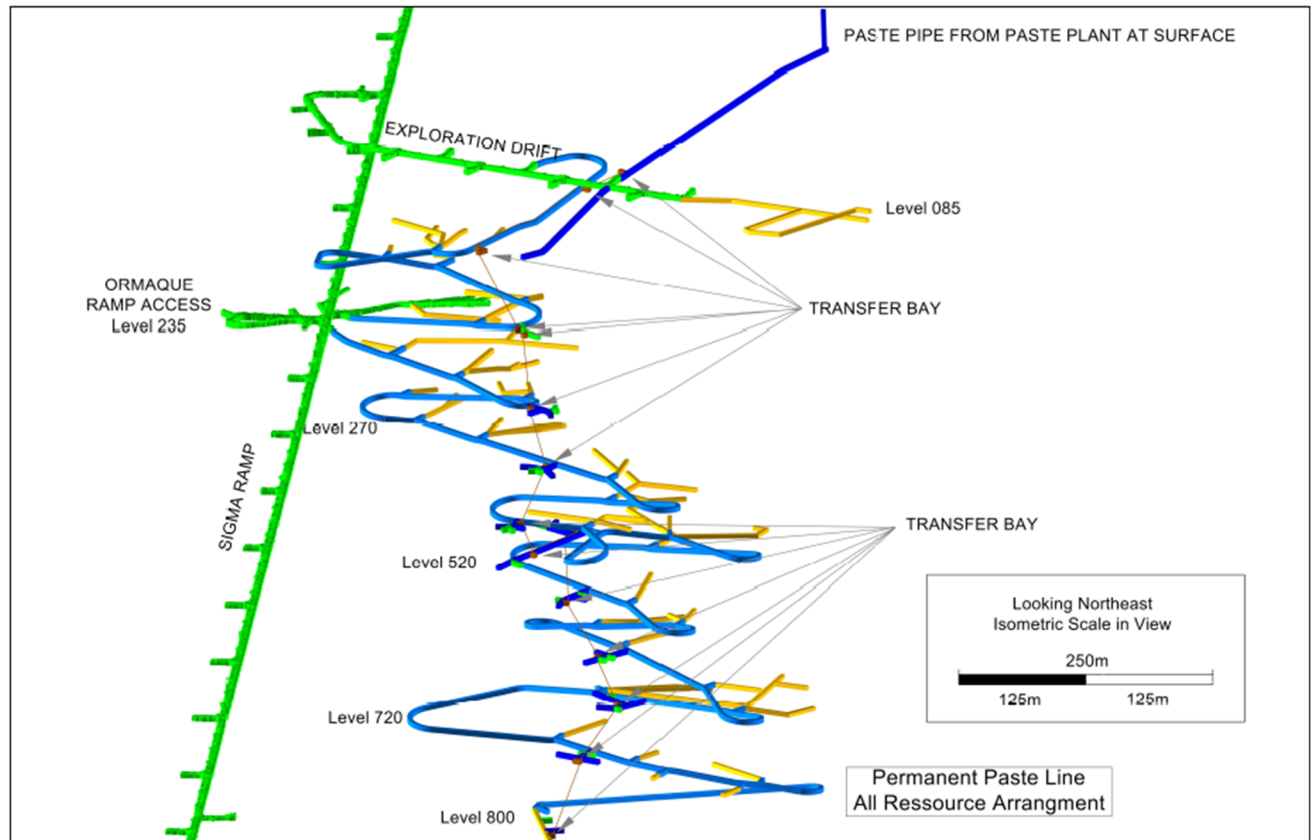

Figure 18-14: Proposed Ormaque Paste Backfill Reticulation Network (Eldorado 2024)

## 19 Market Studies and Contracts

### 19.1 Market

#### 19.1.1 Market Studies

Eldorado currently sells gold doré from the Lamaque operation and hence no formalized market study was completed in respect to future gold production from Lamaque. The market for doré is well established and accessible, with many operating refineries in eastern Canada. Doré bars produced at Lamaque are currently sold to certified refineries in Ontario and Québec. Gold is sold on the spot market, and during 2024 the Lamaque operation realized an average selling price of approximately US\$2,420 per troy ounce.

#### 19.1.2 Price

The price of gold is the largest single factor in determining profitability and cash flow from the Lamaque Complex operations. The financial performance of the project has been, and is expected to continue to be, closely linked to the price of gold. Mineral Reserves have been determined at a gold price of US\$1,450 per ounce. This Technical Report has been completed based on a gold price assumptions of US\$2,000/oz. The projected gold price is based on analysis of price projections from industry peers, investment banks, and analysts.

### 19.2 Contracts

The Lamaque operation has no contracts or hedging in place regarding gold sales and gold is sold at spot price.

The operation has contracts and purchase agreements in place including electrical power, cyanide, diesel, ground support, and explosives. The following items have services agreements in place to support the operation.

- Mining Development
- Production Drilling
- Cable Bolting
- Mining Construction
- Surface and Underground Diamond Drilling

The terms contained within these contracts are typical of and consistent with standard industry practices, and are similar to supply contracts in Québec and Canada. There are no existing or future material contracts required for development of the Lamaque Complex.

## 20 Environmental Studies, Permitting and Social or Community Impact

### 20.1 Regulations and Permitting

The Québec mining industry is subject to federal and provincial laws and regulations. Both levels of government regulate environmental assessments and operational emissions to the receiving environment. EGQ simultaneously provides the project descriptions for permitting to Québec's provincial and Val-d'Or's municipal authorities, allowing the municipality to provide its consent to the Provincial level in an efficient manner. This synergy also allows the Ville de Val-d'Or to receive the various applications for municipal permits specific to municipal regulations from EGQ without issue, as it was previously informed by the joint project notice.

#### 20.1.1 Federal Regulations and Permitting

The federal regime of environmental and social assessment (ESA) for the Project is established by the Canadian Environmental Assessment Act 2012 (CEAA 2012). The regulations designating physical activities lists the construction and operation of a gold mine with a production capacity of 600 tonnes per day (tpd) or more as a designated project for which a description must be submitted to the Canadian Environmental Assessment Agency (CEAAg). The same applies to the expansion of an existing gold mine that would result in an increase in mine operations of 50% or more or an increase in total production capacity reaching 600 tpd or more.

EGQ submitted a preliminary project description to the CEAAg to ensure compliance with the CEAA 2012. Upon review of the preliminary project description, the company was notified on September 29, 2014, by the CEAAg that the combined Sigma-Lamaque mine and mill complex (historic operating area), and the Lamaque South Project (Triangle deposit/mine) would not be subject to a federal ESA. This was because surface disturbance at the Lamaque South Project accounted for only a small fraction of the combined land package (Lamaque South Project and the Sigma-Lamaque mine and mill complex are defined as parts of the Lamaque Complex in Section 1). As a result of EGQ's acquisition of the Sigma-Lamaque mine and mill complex and its integration as part of the Lamaque South Project, the CEAAg in 2014 considered the Project as an expansion that would result in an increase of less than 50% of the area of the mine operations. The current 2,650 tpd mining rate obtained in March 2019 for the Triangle mine from the Provincial MOE, and joint authorization was obtained simultaneously for the 3 km decline project between the Sigma pit and Triangle mine which was completed in 2021.

Since November 25, 2013, the federal Fisheries Act prohibits disturbance of fish habitat without authorization when a project could potentially entail serious harm to fish that are part of a commercial, recreational, or Aboriginal fishery, or to fish that support such a fishery. The waters located on the Lamaque South Property do not directly support a commercial, recreational, or Aboriginal fishery, nor do the fish species indicated during the baseline survey performed on the Lamaque South Property support such a fishery. Therefore, an authorization pursuant to section 35(2) of the Fisheries Act, was not required for this Project.

A request for clarification was requested in 2019 for the small expansion of the north-west part of the Sigma tailings facility (Sigma TSF) and Fisheries and Oceans Canada (DFO) clearly expressed the company's non-subjugation. This exclusion was reiterated in November 2021 by DFO for the future North Basin project to be constructed northwest of the Sigma TSF.

The Metal Mining Effluent Regulations (MMER) pursuant to section 36 of the Fisheries Act, and administered by Environment Canada, will apply in some form. The final effluent quality has been submitted since 2014 for

toxicity and deleterious substances testing as the Environmental. An Effects Monitoring Program will continue to apply; seven annual cycles have been completed. The study design for the eighth cycle was submitted on March 5, 2024, field tests were completed in the autumn of 2024, and the eighth cycle interpretation report will be delivered in 2025.

Already authorized by the MELCCFP at the provincial level (CA#31 – 2018), the exploitation of the Ormaque deposit does not trigger the criteria for subject to federal regulations as mentioned above.

There are nuclear probes used as density meters in the Sigma mill that are registered by the Canadian Nuclear Safety Commission (CNSC). Permits were updated and all employees required to maintain the equipment are trained according to the CNSC standards. Two Radiation Safety Officers (RSO) are on duty.

## 20.1.2 Provincial Regulations and Permitting

### 20.1.2.1 Environmental Quality Act

In Québec, operators are required to obtain a Certificate of Authorization (CoA) from the Ministre de l'Environnement prior to construction and subsequent operation of any industrial facility.

Key provincial permits were obtained for the construction and the operation of the mine in 2017-2018. The same rules applied for the complete renovation and operation of the Sigma mill and the associated tailings storage facility (Sigma TSF). EGQ achieved commercial production in the second quarter of 2019.

MELCCFP is the Québec entity responsible for environmental protection and the conservation of biodiversity to improve the environmental quality of life. This department is responsible for the control and enforcement of laws and regulations concerning environmental protection, including the analysis of application to certificates of authorizations and other permits. The department also regulates the prevention or reduction of the contamination of water, air, and soil, drinking water quality, measures against climate change, as well as the conservation and protection of wildlife and its habitats.

The applicable provincial ESA regime is set out in Chapter I of the Environment Quality Act (EQA) of Québec, which establishes the provisions of general application. Chapter II outlines the provisions of the territory covered by the James Bay and Northern Québec Agreement. The Lamaque South Project is located south of that territory so that only Chapter I is of interest for the Project.

The main sections of Chapter I of the EQA associated with obtaining CoA or other permits are Section 22 (most of industrial activities that may contaminate), Section 31.1 (environmental and social assessment process), Section 32 (drinking water and domestic wastewater) and Section 48 (atmospheric emissions). As well, now that the Project encompasses the Sigma-Lamaque mine and mill complex (processing plant with waste rock storage area, tailings impoundment area and associated water treatment facility), the Company, subject to a de-pollution attestation under Section 31.11 of the EQA, sent this document in 2018 to the MELCCFP. This document is renewable every five years and identifies the environmental conditions that must be met by the industrial facilities when carrying out its activities. An update to the de-pollution attestation document was submitted in 2024.

This attestation compiles all the environmental requirements related to the operation of an industrial facility already stated in the former CofA. The operator of an industrial facility must apply for a de-pollution attestation within 30 days following the issuance of the CofA under Section 22 of the EQA for the operation of its mine project. Once the attestation is issued, annual fees are applicable on mine operation rejects in the environment. The fees are calculated on contaminant load to air and water and tonnage of stored industrial waste on land, sludge, waste rock, and mill tailings.

The Bureau des audiences publiques en Environnement (BAPE) Regulation – the legal governmental body that manage all official environmental public hearings in the province – stated that the BAPE process does not apply to an increase of the maximum daily extraction capacity of a metal ore mine existing on March 23, 2018, even when a result of that increase is equivalent to 50% or more of the then authorized maximum daily extraction capacity. The Mining Lease BM-1048 was effectively delivered on March 14, 2018.

Subsequently, two CofAs were revised and received. The first was the Lamaque Mining CoA allowing the increase of the mining rate from 1,800 tpd to 2,650 tpd and the development of the underground decline connecting the Triangle mine site to the Sigma metallurgical plant. The second was the Sigma milling / crushing CoA, both of which were harmonized at 5,000 tpd as the previous crushing CofA was previously capped at a rate of 3,000 tpd.

The crushing rate of 3,000 tpd at Sigma was harmonized with the Sigma mill's operating rate historically set at 5,000 tpd from the CA#28 amendment. This metallurgical harmonization of the two primary functions of the Sigma mill was agreed to by the MELCC on January 28th, 2020, with the renewal of CA#28 which were both logically harmonized at 5,000 tpd.

In 2020, an amendment of the Triangle Mine CofA was completed to allow for the construction of a strategic decline, approximately 3 km long, providing for straight-line underground transportation for ore from the 380 m level of Triangle mine to the Sigma mill instead of using a 17 km public road circuit on the surface. The construction was completed with inauguration of the decline taking place on December 14, 2021. Electric mining equipment will be gradually introduced, replacing the diesel engine fleet currently in use to create an environmental carbon-free ramp between the two operational units of EGQ. Two electric trucks were already put into operation in 2024. As mentioned previously, this CofA amendment also allowed a strategic increase of the extraction rate at Triangle Mine from 1,800 tpd to 2,650 tpd agreed to by the Provincial MOE (MELCC) on March 23, 2020.

On July 1, 2020, the two previous sister companies that managed the two operational units of the joint venture (Lamaque mine and Sigma mill) were merged under a new corporate name, (EGQ). Moreover, on July 1, 2021, EGQ acquired its immediate eastern neighbor, QMX Mining Corporation.

Other permits and authorizations from both the MERN and the MELCCFP, Régie du Bâtiment (Québec Construction and Petrochemical Agency), Hydro-Québec and the MFFP, for various components of the overall project development work are required. These applications were previously submitted as part of the ongoing process of developing the site and are not anticipated to impact the Project schedule because all these authorizations were received in 2018 through 2019, mainly for the capacity increase and expansion of the Sigma TSF and its static / seismic (dynamic) upgrades to support legally the mid-long term production strategy of EGQ.

The main projects from 2020 through 2021 for EGQ included the construction of the run of mine ore dome as well as two additional leach tanks at the Sigma mill. In addition, refurbishment of the tailings pipelines linking the Sigma mill to the Sigma TSF was completed according to standards that match the requirements of the International Cyanide Code (ICMI).

As part of the Phase IV work and raising of the dikes of cell B2 at the Sigma tailings pond, in 2022, compensation of 2,200 m of the water environment was requested by the MELCCFP. Fish habitat was affected by the deposition of waste rock essential to ensure that the dike was stabilized at the required safety factor. As a result, in 2024, a project was initiated by EGQ at Lake Florentien to compensate for this loss of fish habitat. The compensation project consisted of protecting the lake's spawning ground by relocating the public boat ramp.

At this time, the four deposition cells of the Sigma TSF are all raised to their expected level which will allow a deposition of residues until Q4-2028 according to the current planning (phases VIa and VIb). A water basin, already authorized by the MOE, will be built to the north of cells B1-B2 from Q1-2025. In addition, a portion of the missing perimeter ditch will be completed to the west of cell B2 and south of cell B1. This work, which will complete the entire perimeter ditch of the Sigma TSF, will be completed in Q4-2024.

The exploitation of the Ormaque deposit authorized by CoA#31 requires an update based on the new geochemical characteristics of the deposit. Preliminary results from drill core demonstrate some potential for acid generation (PAG) and leaching of waste rock, ore, and tailings. A new application for an amendment to the Authorization will be submitted to the MELCCFP to incorporate these new elements.

The amendment of CoA#31 will add an ore extraction tonnage of 2,500 tpd from Ormaque to the 2,650 tpd already authorized from the Lamaque mine (Triangle deposit) so that the authorized CA#28 Sigma of 5,000 tpd can be optimized from these two sources.

All environmental studies have been completed to support the current CoAs and assess the environmental issues, there are no known environmental issues that would materially limit the extraction of the mineral reserves.

### **20.1.2.2 Permitting for 2025**

In 2025, EGQ will work on an application for authorization from the MELCCFP for the construction and operation of a new paste backfill plant. This Authorization application will be divided into two phases. The first phase consists of backfilling the Triangle mine stopes only, while the second phase will include backfilling Ormaque mining stopes.

As part of the ongoing bulk sampling work that will continue in 2025, a second phase of the environmental geochemical characterization program will be conducted with the objective of validating the data already obtained from the first phase of the study. The management of the materials (ore stockpile, waste rock pile, and tailings) will be planned according to the analytical results obtained. The Authorization request will be adjusted according to the results of this program.

EGQ will apply for a CofA renewal for the optimization of the Sigma TSF progressive reclamation starting with B1 cell in 2025 and further for the other cells.

In 2025, EGQ will continue the studies already underway and required for the future application for the historic Lamaque TSF.

All water from the mill tailings pulp, dewatering of the historic Sigma-Lamaque underground mine, industrial waters from both the Triangle mine site, and the Sigma metallurgical plant are currently channeled to a strategic single point called the "Sigma Effluent" where quality control of the final legal effluent is managed.

This optimized strategy endorsed by Eldorado's Independent Tailings Review Board (ITRB), will ultimately optimize the volume capacity of the Sigma TSF with yearly phases of consolidation and efficient water management.

Finally, the two main restoration plans for EGQ (Sigma and Lamaque South) were endorsed by the Natural Resources and Forest Ministry (MRNF) in 2022 and 2024 respectively for a total of CAD\$12.6 M. These financial bonds are already held by the Government.

The Triangle mine is fully covered with all the necessary environmental authorizations required by the Provincial MOE. CofA 7610-08-01-70182-29, allows mining of all the Triangle zones, this CofA was received in 2018 then renewed in 2020.

An update of the BM-1048 mining lease will eventually be required as the deposit at depth bifurcates to the north and may continue outside the footprint of the current lease. Through the Québec government's omnibus bill 103, it is planned to incorporate administrative improvements allowing any increase in the surface area of existing leases in the Mining Act (M-13.1) and EGQ will therefore take advantage of the provisions already adopted.

The Ormaque deposit is included in Sigma's CoA #31 (7610-08-01-70095-31), the geographic coverage includes the Ormaque and Parallel deposits and allows for mining at a maximum rate of 2,500 tpd. No mining lease is required as this deposit coincides with the company's historical mining concessions.

Engineering studies required by the Provincial MOE have been commenced to provide certainty to this ministry regarding geochemical, geotechnical, and hydrogeological characterization beyond the 12 level (-453 m), the CofA #31 already allows the Ormaque deposit to be mined to this depth. A bulk sample was extracted from the upper part of the Ormaque deposit and processed in the fourth quarter of 2024.

### 20.1.2.3 Mining Act and Associated Regulations

The application for a mining lease must be accompanied by a survey of the parcel of land involved, a project feasibility study, and a scoping and market study regarding processing in Québec. Unlike metal concentration, which is considered as ore treatment, gold refining is considered as metal processing. Also, according to the Québec Mining Act, a public consultation was held in Val-d'Or to support the mining lease request and received March 14, 2018.

The Mining Act also stipulates that a mining lease cannot be granted until a rehabilitation and reclamation plan (or closure plan) is accepted and a CofA for mining required under the EQA has been issued. When the closure plan is accepted, proponents have 90 days to make first payment of the security deposit of 100% of the estimated cost of reclamation work. Payments are distributed over 3 years, i.e., 50%, 25% and 25%. Rehabilitation and reclamation work must begin within three years after operations cease. MRNF may on exception require work to commence before this deadline, and it can authorize an extension. An initial extension may be granted for a period not exceeding three years, and for additional periods not exceeding one year.

EGQ is managing three distinct Remediation and Reclamation Plans (RRP) for the Lamaque Complex and an additional three plans from sites acquired from QMX as follow in Table 20-1.

**Table 20-1: Remediation and Reclamation Plans**

RRP N°	RRP Name	Acceptance	Renewal	Surety Bonds (CAD\$)
8341-0184	Sigma (mill + TSF site)	Jan 14, 2022	Jan 14, 2027	7,514,829
8341-0199	Exploration	Feb 07, 2022	Feb 07, 2027	567,664
8341-0247	Lamaque South (mine site)	Aug 01, 2024	Aug 01, 2029	5,060,600

The total of the surety bonds for closure of the Lamaque Complex is CAD\$13,143,093.

The three Lamaque Complex RRP's filed by EGQ follow the strict guidelines for preparing mine closure plans in Québec, last published by the Provincial MERN in November 2017 (ISBN 978-2-550-79804-0 PDF), covering the entire project life cycle, including post-closure monitoring (physical stability, environmental, agronomical), maintenance programs, and the Emergency Response Plan prior to any approval.

The guidelines also describe the requirements for water management and monitoring during operations, closure and post closure. EGQ has monitoring systems in place monitor water quality and discharge quantities which are reported regularly to the appropriate authorities.

Extractive waste facilities (tailings and waste rock) are also monitored with quality and quantity reported on a regular basis. EGQ also undergoes third party audits of the extractive waste facilities design and construction as part of Eldorado's corporate governance.

Closure designs are based on the Provincial requirements and include the removal of site infrastructure and rehabilitation of the disturbed areas. Cover systems will be implemented over the facilities to limit oxidation or leaching of metals present in the extractive waste. If required long term water treatment will be implemented to ensure discharge water from facilities remains within discharge limits.

Mine closure costs were evaluated in Q4 of 2024 to assess the existing RRP's and future plans for the operation using current construction unit rates. Closure costs are discussed in Section 1.

Government authorities have not issued mining concessions since 1982 but recognize active concessions as equivalent to mining leases.

## 20.2 Consultation Activities and Social Economic Setting

### 20.2.1 Context

Eldorado has a long history of exchange and communication with the neighbors of its operations and various communities of interest and priority stakeholders. The first information-consultation process with stakeholders, initiated by the project promoters at the time, began in 2013, six years before the mine declared commercial production in March 2019. An initial consultation committee was set up in 2014, followed in 2015 by the creation of a full-fledged Monitoring Committee as defined in the Mining Act.

Eldorado has maintained its practices in pre-consultation and consultation with its communities of interest and priority stakeholders upstream of the regulatory processes for its various projects. Examples include the consultations carried out in 2019 through 2020 during development of the underground ore transport decline, in 2021 during construction of the Ormaque exploration drift, and recently during the pre-consultation process for the prefeasibility of the Lamaque Tailings Storage Facility (Lamaque TSF) Stabilization and Operation Project, which began in May 2022.

These information and consultation processes have all been carried out proactively and voluntarily as part of the prefeasibility phase of the projects, i.e. upstream of regulatory approvals. This approach enables EGQ to integrate the concerns and issues perceived by communities of interest into project design, and to plan mitigation measures to address the issues raised.

### 20.2.2 Feedback Mechanisms and Means of Communication

Various means of communication have been introduced over the years to establish and maintain dialogue with the community and various communities of interest and stakeholders, including:

- An active Monitoring Committee that meets at least five times a year (including an annual meeting);
- A regularly updated website (including documentation section);
- A dedicated website for the Monitoring Committee (including a documentation section containing meeting minutes and presentations);
- Written communications to citizens (notices of work, drilling, etc.);
- A newsletter (published four times a year) sent by e-mail to newsletter subscribers;
- Specific newsletters based on major news items (over 1,000 subscribers);
- A Feedback System with four official communication channels managed by the community relations team;

- There are two resources dedicated to community relations and specifically to public participation initiatives;
- A dedicated community relations e-mail address administered daily by the Communications and Community Relations team;
- Stakeholder Management System (Boréal);
- The annual Neighbourhood Party, an opportunity for neighbours to chat with the Eldorado team;
- Maison Lamaque serves as a community relations office, according to needs and requests;
- There are five regularly updated social media platforms;
- A Community Investment Program, including a volunteer squad.

### 20.2.3 Sustainability Integrated Management System - Toward Sustainable Mining Compliance

Eldorado is committed to responsible mining and sustainability excellence, from providing safe, inclusive workplaces and engaging with our stakeholders, to ensuring healthy environments and growing local communities where we operate. Responsible mining practices are embedded in Eldorado's Values which are the behaviors that ignite our culture: Integrity, Courage, Collaboration, Agility, and Drive. Consistent with our Values, the Eldorado Sustainability Integrated Management System (SIMS) is an integral part of our mission to build a sustainable, high-quality business in the gold mining sector.

SIMS is our minimum performance standards and include discipline specific standards for Occupational Health and Safety (OHS), Environmental Performance, Social Performance, and Security. It also includes general standards covering areas such as risk, crisis, and contractor and supply chain management. SIMS is aligned with the following requirements:

- World Gold Council's Responsible Gold Mining Principles;
- Mining Association of Canada's Towards Sustainable Mining (TSM) (Level A);
- Voluntary Principles on Security and Human Rights;
- International Cyanide Management Code.

The objective of SIMS is regulatory compliance, compliance with Eldorado standards, compliance with voluntary commitments, responsible risk management, and continuous improvement. Where local legislation or regulation exceeds the requirements of these standards or vice versa, the site is expected to meet the more stringent requirements. The program was launched in 2021. Eldorado implemented the Mining Association of Canada's Towards Sustainable Mining program at the same time.

In the fall of 2022, EGQ conducted its first external audit of the Lamaque Complex, to evaluate these sustainable development management systems. This external audit was conducted by PwC and covered all protocols of the Towards Sustainable Mining (TSM) initiative.

The audit took place over an entire week and assessed EGQ's management systems for the various protocols, as well as the way they are integrated into operations. Eldorado received ratings ranging from A to AAA for all protocols.

### 20.2.4 Socio-economic Environment

In 2014, a socio-economic information survey was carried out for the Lamaque South project (now known as the Triangle deposit) as part of an environmental baseline study. SIMS requires that social baseline information be updated to reflect material changes in the project or every three years, and a new social baseline survey was therefore conducted in 2021 by an independent third party. Interviews with key stakeholders were conducted to support the information gathered during the literature review.

The research and results presented in the following sections aim to assess and understand the following items.

- The social context in which EGQ sites operate, including economic, cultural, educational and health indicators.
- Demographic characteristics of local communities, including identification of indigenous and vulnerable populations in the area.
- Local, regional and national economic activities and labour markets
- Land use, tenure, rights and titles, and traditional territories.
- Recent migratory and emigratory flows, and the potential influx of migrants into the region.

The study area corresponds to "Greater Val-d'Or", i.e. the city of Val-d'Or and all the surrounding neighbourhoods: Dubuisson, Sullivan, Val-Senneville, Vassan, Colombière and Louvicourt. The Anishnabe Nation communities of Lac-Simon and Kitchisakik were also included in the study.

The Lamaque Complex is in the Val-d'Or gold district, approximately one kilometer from the urban perimeter of the city of Val-d'Or in the Abitibi-Témiscamingue administrative region of the Vallée-de-l'Or Regional County Municipality (MRCVO). The Lamaque Complex lies entirely within the municipality of Val-d'Or. Responsibility for land use planning is shared between MRNF (Ministère des Ressources naturelles et des Forêts) the MRCVO Vallée-de-l'Or Regional County Municipality and the municipality of Val-d'Or.

#### **20.2.4.1 City of Val-d'Or**

Val-d'Or was first settled in the early 20th century, when major gold discoveries were made near Demontigny and Blouin lakes. Rumors of rich gold deposits attracted prospectors. Promising veins were discovered in various mines: Sullivan (1911), Siscoe (1915), Lamaque (1923), Sigma (1933) and many others (Ville de Val-d'Or, 2021).

Val-d'Or became a village municipality in 1935 and a city municipality in 1937. Val-d'Or expanded its territory and population in 1968 with the annexation of the municipalities of Bourlamaque and Lac Lemoine. The outlying areas of Dubuisson, Sullivan, Val-Senneville, Vassan and Louvicourt were officially amalgamated into the City of Val-d'Or as we know it today on January 1, 2002 (City of Val-d'Or, 2021).

The surface area of the city of Val-d'Or, including outlying districts, is 3,983 km<sup>2</sup>. Its current population is estimated at 33,024 (MRCVO forecast, 2021a). The main language spoken at home by Val-d'Or residents is French (96% of the population). 2% of Val-d'Or's population speaks English at home (ISQ, 2011).

#### **20.2.4.2 Economic Activities**

As indicated in the 2020 edition of the Abitibi-Témiscamingue Trend Chart, the region boasts 5,031 economic establishments (businesses, industries, shops). Of these, more than half are concentrated in the Vallée-de-l'Or Regional County Municipality (MRCVO) and the City of Rouyn-Noranda. According to data from the Observatoire de l'Abitibi-Témiscamingue, in 2021, the MRCVO's main employers will include three organizations with 1,000 or more jobs, two with 500 to 999 jobs and five others with 200 to 499 jobs, including Eldorado.

According to the economic vitality index developed by the Institut de la statistique du Québec, Val-d'Or fell from 230th place in 2016 (out of 1,262) to 249th place in 2018. Despite this slide in locality rankings, the City of Val-d'Or nonetheless remains in the top quintile of the most dynamic localities in the province and boasts an economic vitality slightly higher than the average for other Abitibi-Témiscamingue communities (ranked 12th regionally in 2018), with a significant 10% increase in median income. The regression observed is mainly explained by the slight decrease in population from year to year.

### 20.2.4.3 Heritage

The City of Val-d'Or has several important heritage sites recognized by the Québec Ministry of Culture and Communications, including the former Lamaque mine and Bourlamaque mining village national historic site, which developed in the region during the Great Depression of the early 1930s. The site consists of an old mine and a mining village, the first neighbourhood of Bourlamaque. These facilities, including the Cité de l'Or tourist site, are located on the periphery of the Project.

### 20.2.5 Community Engagement Plan

EGQ has adopted a Two-Year Community Engagement Plan 2024-2026, the main aim of which is to maintain a high level of social acceptability with regard to the mining activities carried out by EGQ. The Engagement Plan echoes the information and issues identified through the social baseline study (updated every three years). The plan's objectives include:

- Identification of targets and priorities for community involvement, and the measures to be deployed to meet them efficiently;
- Adapting our community involvement practices in line with changes in operations, authorization procedures and the assessment of associated impacts on the human environment;
- Facilitating the monitoring and maintenance of compliance with the various standards, directives, policies and procedures applicable to environmental relations.

### 20.2.6 Eldorado Gold Québec Monitoring Committee

The EGQ Monitoring Committee was officially established in 2015, making it one of the longest-lived regulatory committees in the Québec mining sector.

For nine years now, the Committee has pursued its mission of being a privileged channel of information and dialogue, involving the community in the monitoring of the company's activities and projects, always with a view to the continuous improvement of operations. Today, the Monitoring Committee is made up of 16 active members and alternates representing the various sectors of activity in Greater Val-d'Or, as well as residents of the neighbourhoods surrounding the mine's operations. Committee members meet at least five (5) times a year.

#### 20.2.6.1 Subcommittee of the Monitoring Committee (Working Group)

Eldorado committed in 2021 to identifying social risks related to its high-growth activities and establishing action plans to mitigate these potential risks or impacts. A sub-working group was set up in autumn 2021 to identify priority risks, opportunities and actions to be taken in the short or longer term. This working group has five participants: three members of the Monitoring Committee and two outsiders from the socio-community and socio-economic sectors.

In addition to its initial mandate to monitor the implementation of the 2021 action plan, the Benefits and Impacts Subcommittee accepted two new mandates in the fall of 2022. One mandate involved consultation on the Lamaque TSF stabilization and operation project and on the future of tailings disposal, while the other concerns the mine's social closure plan.

### 20.2.7 First Nations Consultation

EGQ's operations in the Greater Val-d'Or area are located on the ancestral territory of the Lac Simon Algonquin Anishnabe Nation and on the territory covered by the Algonquin Nation's comprehensive claim filed

in 2000. The Lac Simon Anishnabe community is located 37 km south of Val-d'Or, on the west shore of Lac Simon.

Eldorado has various exchange mechanisms specific to First Nations, including:

- Indigenous community information and consultation policy for exploration activities;
- Policy of commitment to exchange and dialogue with indigenous peoples;
- Annual exploration meetings, site visits and direct communications;
- Seat reserved for a member of the Lac Simon community on the Monitoring Committee since its creation.

Members of the Lac Simon Anishnabe Nation have chosen to actively participate in the consultation process, and a representative of the Lac Simon community is present on the Monitoring Committee. Since the creation of the Monitoring Committee in 2015, the Lac Simon Anishnabe Nation representative has been present on the Monitoring Committee on an ongoing basis.

Since its arrival in Abitibi-Témiscamingue, in unceded Anishnabe traditional territory, EGQ has committed to working with communities in a spirit of mutual respect to develop local economies and offer sustainable opportunities. EGQ is committed to working with the communities affected by its activities to maximize positive benefits in terms of employment and training, business opportunities, and community and social development.

A number of gestures and initiatives have been put in place, including financial support for a day camp in the Kitcisakik community, tours of our operating sites by members of the Lac Simon Anishnabe Nation Council, cooperation with the Kitci Amik Centre Régional d'Éducation des Adultes (CRÉA) in Lac Simon for the construction of an urban pavilion for Indigenous students, and more recently, the development of Indigenous awareness video vignettes for all our employees and contractors. We are also a partner of the Université du Québec en Abitibi-Témiscamingue (UQAT) with the School of Native Studies for a research chair on Insertion and job retention of members of the Kitcisakik and Lac Simon Anishnabe communities within EGQ as well as the TESABIDAN teaching, sharing and reconciliation site at UQAT's Val-d'Or campus.

In June 2021, EGQ made a commitment to the Anishnabe Nation of Lac Simon and the community of Kitcisakik towards the development of a Collaboration Agreement aimed at maximizing business opportunities, fostering employability and integration of the Anishnabe workforce, respect for the environment and socio-economic development. Currently there are no agreements in place and negotiations are in progress.

#### **20.2.7.1 Consultation Specific to the Lamaque Tailings Facility Stabilization and Operation Project**

More specifically on the Lamaque TSF Stabilization and Operation Project, the Lac Simon Anishnabe Nation was consulted on three occasions, in November 2021, November 2022 and January 2024. Comments submitted in 2021 by the Department of Natural Resources regarding the future tailings disposal site were incorporated into the alternatives study conducted by WSP-Golder (2022). An update on the Lamaque RAP Stabilization Project was provided to the Lac Simon Anishnabe Nation during annual meetings with the Lac Simon Department of Natural Resources in January 2024.

#### **20.2.7.2 Ormaque Project Information and Consultation Process**

EGQ met and consulted with the Lac Simon Anishnabe Nation in 2021 as part of the development of the Ormaque exploration drift. Various updates on the Ormaque Project were provided during annual meetings with the Department of Natural Resources.

## 20.2.8 Consultation Summary

EGQ will continue to be proactive in its engagement with all stakeholders affected by current and future operations at the Lamaque Complex. The long standing consultation process and engagement plans will remain in effect through the full project lifecycle and to maintain the longterm sustainability of the Project.

## 21 Capital and Operating Costs

The capital and operating cost estimates presented in this Technical Study for the Lamaque Complex are based on prefeasibility-level estimates for the currently producing operation, centered around the mining of the Mineral Reserve from the upper Triangle, Parallel, and upper Ormaque deposits. Estimate information is backed by six years of operating and construction data from ongoing mine operations.

All capital and operating costs in this report are United States Dollars (US\$) unless stated otherwise.

### 21.1 Mineral Reserve Capital Costs

The capital cost estimate for mining and processing the Mineral Reserve is effective Q4 2024 and expressed in constant dollars.

The total capital cost for the life of mine consists of \$226.5 M in growth capital and \$270.3 M in sustaining capital, as summarized in Table 21-1..

**Table 21-1: Capital Cost Estimate**

Description	Growth (\$M)	Sustaining (\$M)	Total (\$M)
Mining	100.8	200.9	301.7
Processing	96.4	11.8	108.2
General and Administration	1.3	44.1	45.3
Infrastructure	0.0	0.0	0.0
Exploration and Delineation Drilling	28.0	4.7	32.8
Closure	0.0	11.8	11.8
Salvage (credit)	0.0	(3.0)	(3.0)
<b>Total</b>	<b>226.5</b>	<b>270.3</b>	<b>496.8</b>

#### 21.1.1.1 Type and Class of Cost Estimate

The capital cost estimate pertaining to this section of the Technical Report is at a prefeasibility level. The estimate meets the definition of an AACE Class 3 estimate. The accuracy of the capital cost estimate developed for the Mineral Reserve qualifies as -15%/+25%.

The largest portion of the growth capital is allocated to mining (61%), which includes mine development, mining equipment, and major rebuilds largely based on operational data and contracted unit costs. The second largest component is process (13%) for paste plant construction.

#### 21.1.1.2 Cost Basis, Labour and Productivity

Costs, labour, and productivity assumptions are based on current development mining rates, recent tailings construction projects carried out at the Sigma TSF, and ongoing projects that were carried out at the Sigma mill in recent years.

#### 21.1.1.3 Growth Capital

The growth capital required for the Mineral Reserve totals \$226.5 M, as shown in Table 21-2.

**Table 21-2: Growth Capital Items**

Description	Years	Total (\$M)
Ormaque Mine Infrastructure	2025 - 2029	90.5
Ormaque Rock Dump	2025 - 2028	10.2
Sigma TSF Expansion	2027 - 2028	20.8
Sigma TSF North Basin	2025 - 2026	34.8
Lamaque TSF Stability	2026 - 2027	10.1
Paste Plant	2025 - 2026	30.7
General and Administration	2025 - 2031	1.3
Exploration	2025 - 2026	28.1
<b>Total</b>		<b>226.5</b>

**21.1.1.3.1 Mine Infrastructure**

Mine infrastructure costs include development and supporting infrastructure in the Ormaque deposit.

**21.1.1.3.2 Sigma TSF**

The Sigma TSF will be expanded in 2027 and 2028 for additional tailings capacity through to the end of the mine life.

**21.1.1.3.3 Sigma TSF North Basin**

The North Basin at the Sigma TSF is planned for construction in 2025 and 2026. The basin will be built directly to the north of the current TSF, with the aim of eliminating large standing water ponds on the TSF surface.

**21.1.1.3.4 Lamaque TSF Stability**

Stability improvements to the historic Lamaque TSF are planned in 2026 to 2027 after additional site investigations and permitting are completed.

**21.1.1.3.5 Paste Plant**

Paste plant equipment engineering, equipment procurement, and initial work is planned in 2025 with construction to be completed in 2026.

**21.1.1.3.6 General and Administrative**

Costs are associated with smaller projects and IT programs to support growth.

**21.1.1.3.7 Exploration**

Exploration costs are for the budgeted annual drilling programs.

**21.1.1.4 Sustaining Capital**

Sustaining capital required for the Mineral Reserve totals \$270.3 M, see Table 21-3.

**Table 21-3: Sustaining Capital Items**

Description	Years	Total (\$M)
Mining	2025 – 2032	200.9
Processing	2025 – 2032	11.8
General and Administrative	2025 – 2032	44.1
Exploration	2025 – 2027	4.7
Closure	2033 – 2034	11.8
Salvage (Credit)	2034	(3.0)
<b>Total</b>		<b>270.3</b>

#### 21.1.1.4.1 Mining

Underground construction includes the following elements that were estimated based on the recent history of underground construction at Triangle. The largest component (74%) is for development drifts and stope access, and other costs are associated with the following items.

- Dewatering systems and sump pits
- Electrical supply, substations, and U/G power distribution
- Explosives storage
- Detonator storage
- Oil, grease, and lubricant storage
- Used and clean water pits
- Ore raises and chutes
- Secondary ventilation equipment, ventilation doors and walls
- Refuges and dining rooms
- Ablution areas
- Mobile Equipment

The sustaining capital portion of mobile equipment covers the replacement and major overhauls of currently operating mobile equipment. It is based on the fleet requirements defined by the mine plan developed during this study.

#### 21.1.1.4.2 Processing

Costs are associated with ongoing energy efficiency programs and other small improvement programs.

#### 21.1.1.4.3 General and Administrative

General and Administrative sustaining capital are budgeted cost centers supporting the sustaining mining costs.

#### 21.1.1.4.4 Exploration

Sustaining exploration capital is for delineation drilling, with the estimate developed by Eldorado. It reflects the current delineation drilling plan and is priced from the current drilling costs at the Lamaque operation.

#### 21.1.1.4.5 Salvage Value

The salvage value is an allowance for disposal of mine and process equipment, and salvage of metal and wiring.

#### 21.1.1.4.6 Closure Plan

The closure plan is based on Remediation and Reclamation Plans filed with the Québec Ministry of Environment and updated every 5 years. The plans were reviewed in Q4 2024 with costs updated to account for current construction unit rates.

## 21.2 Mineral Reserve Operating Costs

The average operating cost for mining and processing the Mineral Reserves over the mine life is estimated to be \$189.02/t of ore or \$922.25/oz Au. Table 21-4 provides the breakdown of the projected operating costs for the Mineral Reserve.

**Table 21-4: Operating Cost Summary**

Cost Area	Annual average cost (\$M)	Average cost (\$/tonne ore)	Average cost (\$/oz Au)
Underground Mining	96.7	136.00	662.46
Processing	19.0	26.50	129.83
General and Administration	19.0	26.52	129.96
<b>Total</b>	<b>134.6</b>	<b>189.02</b>	<b>922.25</b>

### 21.2.1 Reserve Basis of Operating Cost Estimate

The operating cost estimate for the Mineral Reserve is based on operating data through Q4 2024 and is considered to be above feasibility level accuracy, supported by the actual operating costs from the last six years of production. All operating cost estimates are in US\$.

The operating cost estimate is based on the mine scheduled tonnage per period that was produced by Eldorado.

### 21.2.2 Reserve Assumptions and Exclusions

No cost escalation (or de-escalation) was assumed. The following items were specifically excluded from the operating cost estimate:

- Transport and handling of doré from the mill (included in financial modelling)

### 21.2.3 Mine Operating Cost

Eldorado provided estimates for all underground mine operating costs. The operating unit costs were calculated over the total ore mined from development and production. The unit cost is \$136.29/t of ore.

Triangle mining cost averages \$107.18 per tonne LOM, Parallel mining cost averages \$107.00 per tonne LOM, and Ormaque mining costs average \$170.00 per tonne LOM.

Mining operating costs consist primarily of wages, fuel, electric power, consumables, and equipment maintenance. All level development, except for development detailed in the capital cost section has been allocated to the operating cost.

### 21.2.4 Process Operating Costs

Processing costs include reagents, grinding media, plant maintenance materials, vehicle fuel and maintenance, laboratory services, energy (electricity and natural gas), and manpower required for operation of the Sigma mill. Milling costs for an approximate average production rate of 920 ktpa are estimated at an

average of \$26.50/t. Unit prices for reagent and grinding media were taken from ongoing operations at the Sigma mill.

Maintenance materials were estimated for major equipment based on experience, with allowances added for general materials and per plant area for lubricants and miscellaneous mechanical, piping, electrical and instrumentation materials.

Maintenance and fuel costs for plant mobile vehicles have also been included. Electricity costs were calculated based on Hydro Québec's current rate. The natural gas cost heating was estimated based on the current rates.

### **21.2.5 General and Administration Operating Costs**

The unit cost for General and Administrative costs averages \$26.59/t mined, including administration, finance, environmental, and health and safety departments.

## 22 Economic Analysis

All costs, revenues, and prices are in US\$ unless otherwise noted.

The economic analysis for the declared Mineral Reserves at Triangle, Ormaque and Parallel (the “**Reserve Case**”), is based on a Reserves gold price of \$1,450/oz and a revenue gold price assumption of \$2,000/oz. This economic analysis indicates an after-tax NPV of \$555.0 M, using a discount rate of 5% .

The financial model was subjected to sensitivity analyses to determine the effects of changing gold prices, capital, and operating expenditures on financial returns. This analysis shows that the Project economics are robust and are most sensitive to fluctuations in metal prices.

The financial modeling was carried out based on Mineral Reserves available as of January 1<sup>st</sup>, 2025 and excluded 2024 Q4 production (depletion) of 256,628 tonnes at 8.05 g/t Au that was processed following the September 30, 2024 declaration of Mineral Resources and Mineral Reserves. A surface stockpile of 34,130 tonnes as of December 31, 2024, at a grade of 7.02 g/t, is included in the financial modelling.

### 22.1 Reserve Economic Modelling Parameters

The economic / financial assessment was carried out using a discounted cash flow approach on a pre-tax and after-tax basis utilizing mid-year discounting convention. Gold price was based on consensus equity research of long-term commodity price projections as of Q4 2024. No provision was made for the effects of inflation. Current Canadian tax regulations were applied to assess the corporate federal tax liabilities, while the regulations in Québec were applied to assess the provincial mining duties and tax liabilities.

Mineral Reserves at Triangle are located in zones and splays C1 to C7, to a mining depth of approximately 1,250 m. Mineral Reserves at Ormaque are located in the upper zones (Ormaque zones E009 to E170) to a mining depth of approximately 450 m. The economic analysis also includes Mineral Reserves contained in the satellite Parallel deposit. No Inferred material is included in the economic analysis of the Mineral Reserves.

The economic analysis presented in this section contains forward-looking information with regards to the Mineral Reserve estimates, commodity prices, exchange rates, proposed mine production plan, projected recovery rates, estimation, the realization of Mineral Reserves, estimated costs and timing of capital, sustaining and operating expenditures, construction costs, closure costs and requirements, and schedule. The results of the economic analysis are subject to multiple known and unknown risks, uncertainties, and other factors that may cause actual results to differ materially from those presented here.

Additional risks to the forward-looking information include:

- Changes to costs of production from what are estimated.
- Unrecognized environmental and social risks.
- Unanticipated reclamation expenses.
- Unexpected variations in quantity of mineralized material, grade, or recovery rates.
- Geotechnical or hydrogeological considerations during mining being different from what was assumed.
- Failure of mining methods to operate as anticipated.
- Failure of plant, equipment, or processes to operate as anticipated.
- Changes to assumptions as to the availability of electrical power, and the power rates used in the operating cost estimates and financial analysis.
- Ability to maintain the social licence to operate.
- Accidents, labour disputes, and other risks of the mining industry.
- Changes to interest rates.

- Changes to tax rates and incentive programs.

The economic analysis evaluates revenue, expenditures, taxes, and other applicable factors. The economic analysis was performed using the following assumptions and basis:

- The Mineral Reserves, processing and recovery methods, mining methods, and production schedule as outlined in previous sections.
- The revenue gold price used in the economic model is US\$2,000/oz Au. No price inflation or escalation factors were considered. It is understood that commodity prices can be volatile and that there is the potential for deviation from the LOM forecasts.
- Maximum processing capacity at the Sigma mill is 965,000 tpa.
- Class-specific Capital Cost Allowance rates are used for the purpose of determining the allowable taxable income.
- An exchange rate of CAD\$1.30 per US\$1.00 was assumed to convert operating and capital costs in CAD\$ into US\$.

This financial analysis was performed on both a pre-tax basis and after-tax basis with the assistance of an external tax consultant. The general assumptions used for this financial model are summarized in Table 22-1.

**Table 22-1: Mineral Reserves Financial Model Parameters**

Parameter	Unit	Value <sup>(1)</sup>
Gold Price	\$/oz	2,000
Total Material Mined (Mineralized Material and Waste)	Mt	8.63
Total Material Processed	Mt	5.72
Gold Recovery	%	96.9%
Average Mining Costs	\$/t ore	136.00
Average Process Costs	\$/t	26.50
Average General and Administrative Costs	\$/t	26.52
Total Operating Cost	\$/t	189.02
Transport and Refining	\$/t	2.00
Growth Capital Cost	\$ M	226.5
Sustaining Capital Cost	\$ M	261.5
Reclamation and Closure Cost	\$ M	11.8
Salvage Value (Credit)	\$ M	3.0

All capital costs (expansion, sustaining, reclamation and closure) for the Mineral Reserves have been distributed against the development schedule to support the economic cash flow model.

For the purposes of this financial analysis, reclamation and closure costs of \$11.8 M have been assumed. An overall salvage value of \$3.0 M has been assumed.

Eldorado is the 100% owner of the Lamaque Complex. For purposes of the economic analysis, a royalty rate of 1.00% has been applied to all commercial ounces.

### 22.1.1 Taxation

Eldorado is subject to three levels of taxation, including federal income tax, provincial income tax, and provincial mining taxes.

The current Canadian tax system applicable to mineral resource income was used to assess the annual tax liabilities. This consists of federal and provincial corporate income taxes, as well as provincial mining taxes. The current combined corporate tax rate for Québec is 26.5% (consisting of a 15% Federal income tax rate and a 11.5% Provincial income tax rate) through the year 2024.

Mining operations in Québec are subject to a mining tax on annual profit. The tax rate is a progressive tax based on profit margin shown in Table 22-2. The profit margin is the operator's annual profit divided by the gross value of the annual output. Expenses reasonably attributed to the mining operation along with depreciation, development, and exploration can be applied. The calculations are readily available and posted by Revenu Québec.

A minimum mining tax of 1% is applied on the first CAD\$80M mine-mouth output value and 4% for output over CAD\$80M.

**Table 22-2: Québec Mining Tax Rates**

Profit Margin		Tax Rate
First Tier	0% to 35%	16%
Second Tier	More than 35%, up to 50%	22%
Third Tier	More than 50%	28%

The processing allowance regarding processing assets has been assumed at 10%. The annual profit is calculated by subtracting the following allowances from the gross value of the mine's annual output:

- Direct operating costs
- Royalties
- Depreciation
- Post-production development allowance
- Processing allowance
- Additional depreciation allowance
- Additional allowance for a northern mine
- Additional allowance for a mine situated in Northern Québec

The tax calculations are underpinned by the following key assumptions:

- The property is held 100% by a corporate entity and the after-tax analysis does not attempt to reflect any future changes in corporate structure or property ownership.
- 100% equity financing and therefore does not consider financing expenses.
- Payments projected relating to NSR royalties are allowed as a deduction for federal and provincial income tax purposes but are added back for provincial mining tax purposes.
- Actual taxes payable are affected by certain corporate and tax structuring activities which have been considered.

## 22.1.2 Economic Modelling

Approximately 5.7 Mt of ore will be processed over the life of mining the Mineral Reserves, producing 1.17 Moz Au, Figure 22-1 provides a summary of the payable gold by year.

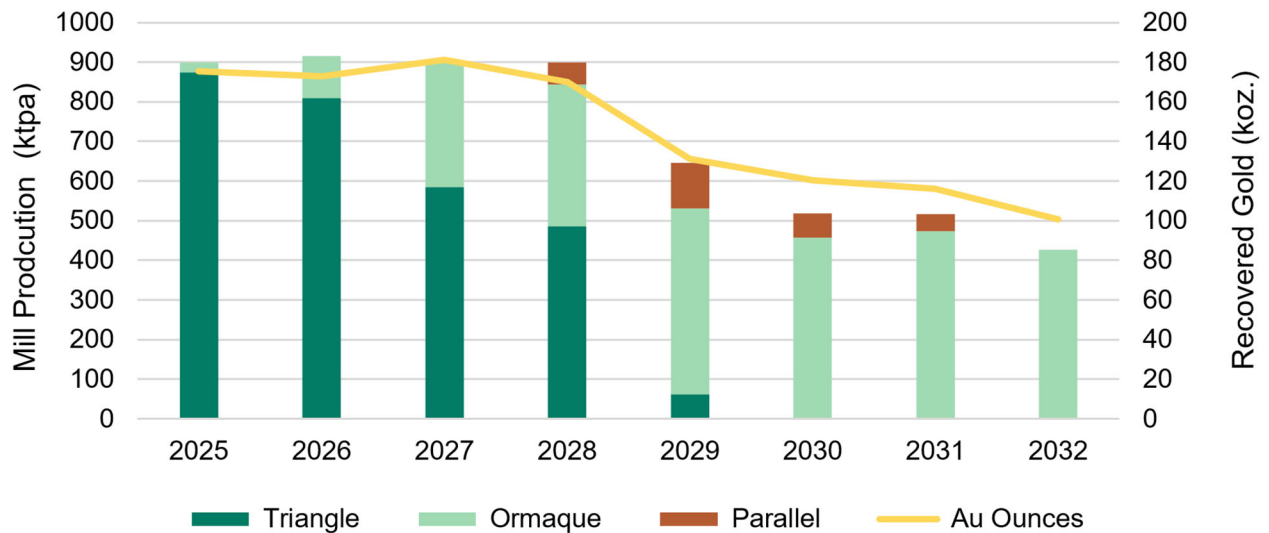

**Figure 22-1: Annual Ore Processed and Gold Produced (Eldorado 2024)**

A 5% discount rate was applied to the free cash flows to derive the NPV on a pre-tax and after-tax basis utilizing mid-year discounting convention. Cash flows have been discounted to Q4 2024. The summary of the financial evaluation results is presented in Table 22-3. The Project’s cashflow remains positive as such there is no calculated internal rate of return or payback period. Capital expenditures are part of ongoing operational development funded by ongoing gold sales and there are no external funding requirements.

**Table 22-3: Financial Analysis Summary (Mineral Reserves)**

Description		Unit	Value
Pre-Tax	Net Cash Flow	\$M	736.1
	Net Present Value (@ 5% discount)	\$M	613.0
After-Tax	Net Cash Flow	\$M	669.4
	Net Present Value (@ 5% discount)	\$M	555.0

A summary of the cash flow model is presented in Table 22-4.

**Table 22-4: Cash Flow Model (Mineral Reserves)**

Parameter	Year	2025	2026	2027	2028	2029	2030	2031	2032	2033	2034	Total
		1	2	3	4	5	6	7	8	9	10	
<b>Production Summary</b>												
Total Tonnes Mined	kt	879	907	923	934	584	518	516	426	0	0	5,688
Total Material Processed	kt	900	915	900	900	647	518	516	426	0	0	5,723
Mill Gold Head Grade	g/t Au	6.24	6.06	6.45	6.07	6.53	7.45	7.23	7.58	0.00	0.00	6.55
Mill Gold Recovery	%	97.0%	97.0%	97.0%	96.9%	96.7%	96.8%	96.9%	97.0%	0.0%	0.0%	96.9%
Gold Production	koz Au	175.3	173.0	181.1	170.0	131.2	120.3	116.2	100.8	0.0	0.0	1,168
<b>Revenue</b>												
Gold Sales	US\$M	350.5	345.9	362.2	340.1	262.5	240.5	232.3	201.6	0.0	0.0	2,335.7
Transport and Refining Cost	US\$M	0.4	0.3	0.4	0.3	0.3	0.2	0.2	0.2	0.0	0.0	2.3
Royalty Payments	US\$M	3.5	3.5	3.6	3.4	2.6	2.4	2.3	2.0	0.0	0.0	23.3
Net Revenue	US\$M	346.7	342.1	358.3	336.3	259.6	237.9	229.8	199.4	0.0	0.0	2,310.0
<b>Operating Expenditures</b>												
Mining	US\$M	96.8	98.8	127.7	116.6	92.0	84.3	85.1	72.5	0.0	0.0	773.6
Processing	US\$M	23.3	23.7	23.3	23.3	17.3	14.3	14.2	12.1	0.0	0.0	151.6
General and Administration	US\$M	19.1	18.6	20.0	22.1	18.0	18.0	18.0	18.0	0.0	0.0	151.8
Operating Costs	US\$M	139.2	141.1	171.0	162.0	127.3	116.5	117.3	102.6	0.0	0.0	1,077.0
<b>Earnings</b>												
EBITDA	US\$M	207.5	201.0	187.3	174.3	132.2	121.3	112.5	96.8	0.0	0.0	1,233
<b>Capital Expenditure</b>												
Growth	US\$M	69.4	79.7	41.0	27.8	5.9	1.8	0.9	0.0	0.0	0.0	227
Sustaining	US\$M	81.7	68.0	62.7	24.8	6.9	7.1	7.6	2.7	0.0	0.0	261
Reclamation and Closure	US\$M	0.0	0.0	0.0	0.0	0.0	0.0	0.0	0.0	5.9	5.9	12
Salvage Value Credit	US\$M	0.0	0.0	0.0	0.0	0.0	0.0	0.0	0.0	0.0	-3.0	-3
Total Capital Costs	US\$M	151.1	147.7	103.7	52.6	12.9	8.9	8.5	2.7	5.9	2.9	497
<b>Pre-Tax Cash Flow</b>												
Pre-Tax Cash Flow	US\$M	56.5	53.3	83.6	121.7	119.4	112.4	104.0	94.1	-5.9	-2.9	736
Cumulative Pre-Tax Cash Flow	US\$M	56.5	109.8	193.4	315.1	434.5	546.9	650.9	745.0	739.1	736.1	
<b>Taxes and Duties</b>												
Taxes and Québec Mining Duties	US\$M	13.7	9.8	7.8	8.2	5.6	7.1	7.7	6.8	0.0	0.0	67
<b>After-Tax Cash Flow</b>												
After-Tax Cash Flow	US\$M	42.8	43.5	75.8	113.5	113.7	105.3	96.3	87.3	-5.9	-2.9	669
<b>Cumulative After-Tax Cash Flow</b>	<b>US\$M</b>	<b>42.8</b>	<b>86.3</b>	<b>162.1</b>	<b>275.5</b>	<b>389.2</b>	<b>494.5</b>	<b>590.9</b>	<b>678.2</b>	<b>672.3</b>	<b>669.4</b>	<b>669.4</b>

A summary of the production costs is provided in Table 22-5. Total cash costs are calculated per ounce on a payable basis using the costs of mining, processing, on-site G&A, refining and transport, and royalties. The average operating cash cost per ounce is \$924. The average all-in sustaining cost (AISC) per ounce is \$1,176.

**Table 22-5: Production Cost Summary (Mineral Reserves LOM)**

Description	Unit	Value <sup>1</sup>
Gold Production	koz	1,168
Mining Costs	US\$ M	774
Processing Cost	US\$ M	152
General and Administration Costs	US\$ M	152
Refining and Transport	US\$ M	2.3
Royalties	US\$ M	23
Total operating cost	US\$ M	1,077
Gold price	US\$/oz	2,000
Cash cost (operating)	US\$/oz Au	924
Sustaining and closure costs (net of salvage value)	US\$ M	270
Total costs (operating and sustaining)	US\$ M	1,347
AISC costs <sup>(1)</sup>	US\$/oz Au	1,176

As defined by the World Gold Council less corporate G&A cost

### 22.1.3 Sensitivity Analysis

A financial sensitivity analysis was conducted using the following variables: capital costs, sustaining costs, operating costs, and price of gold. The after-tax results for the NPV based on the sensitivity analysis are summarized in Table 22-6.

**Table 22-6: Net Present Value (5%) Sensitivity Results (after-tax)**

Sensitivity	Growth Capital	Sustaining Capital	Operating Cost	Gold Price
% change	NPV\$M	NPV\$M	NPV\$M	NPV\$M
-20%	593	599	713	213
-15%	583	588	674	298
-10%	574	577	634	384
-5%	\$564	566	595	469
<b>0% (Base)</b>	<b>555</b>	<b>555</b>	<b>555</b>	<b>555</b>
5%	546	544	515	641
10%	536	533	476	726
15%	527	522	436	811
20%	517	511	397	896

The sensitivity analysis reveals that the NPV was most impacted by changes to gold price. The gold price was evaluated between \$1,600/oz Au and \$2,400/oz Au, at \$1,600 /oz Au the Project economics remained robust with an after-tax of NPV over \$213 M shown in Figure 22-2. The Project economics remain positive at the Mineral Reserve price of \$1,450/oz Au.

Separately, sensitivities were run with a  $\pm 20\%$  variation range in capital costs, sustaining costs, and operating costs. As shown in Figure 22-2, the analysis showed the Project is most sensitive to operating costs, where a 20% increase would result in an after-tax NPV of \$397 M; capital and sustaining cost were less significant,

where a 20% increase in sustaining capital would result in an after-tax NPV of \$499 M; and capital costs having the lowest sensitivity, where a 20% increase would yield an after-tax NPV of \$506 M. Overall, the Project economics remain positive for all sensitivities tested.

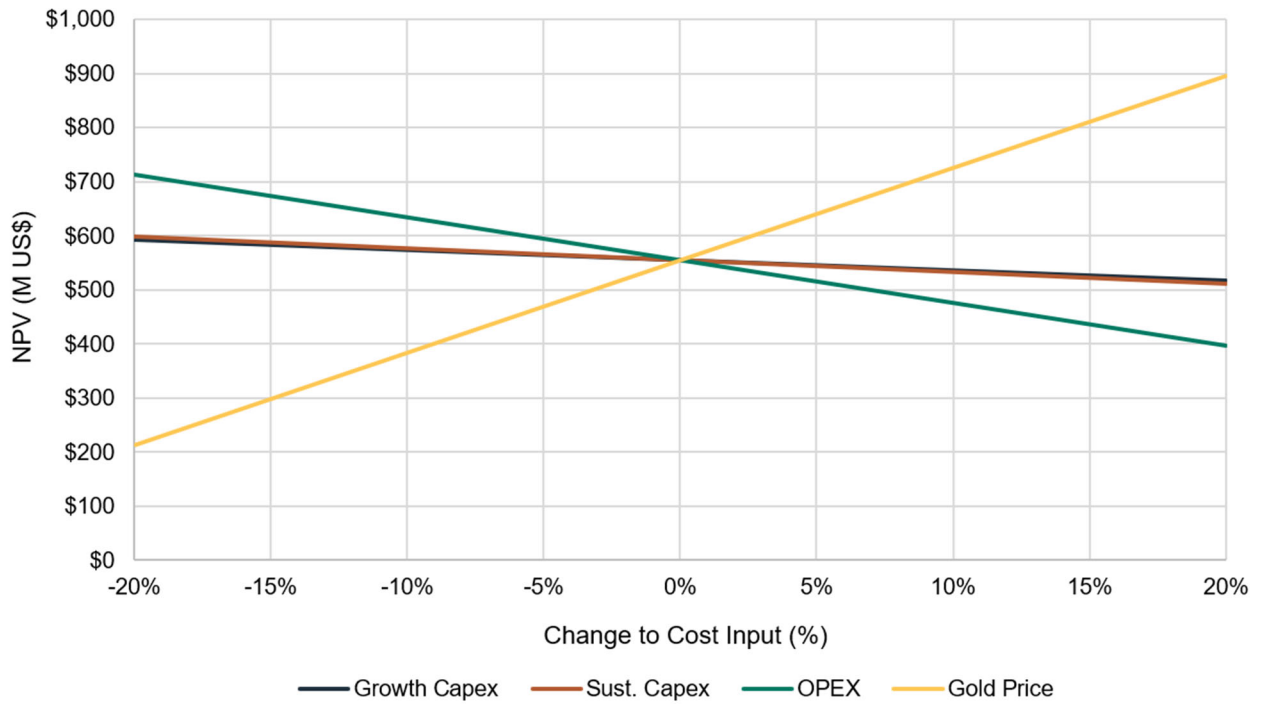

**Figure 22-2: Sensitivity of the Net Present Value (after-tax) to Cost Inputs (Eldorado 2024)**

Sensitivity was also analysed regarding process recovery. Since commercial production began, process recovery has averaged 97.0%, and for economic analysis an average of 96.9% was used for processing the Mineral Reserves. Sensitivities were run from -3% to +3% in 1% increments. At negative 3% (93.2% recovery), the NPV was \$491M, while at plus 1% (97.2% recovery) the NPV was \$561 M. The recovery sensitivity shown in Figure 22-3 indicates that the economics remain robust with an NPV of \$503 M and a 3% recovery loss. The process recovery sensitivity is a close proxy for Mineral Reserve grade sensitivity.

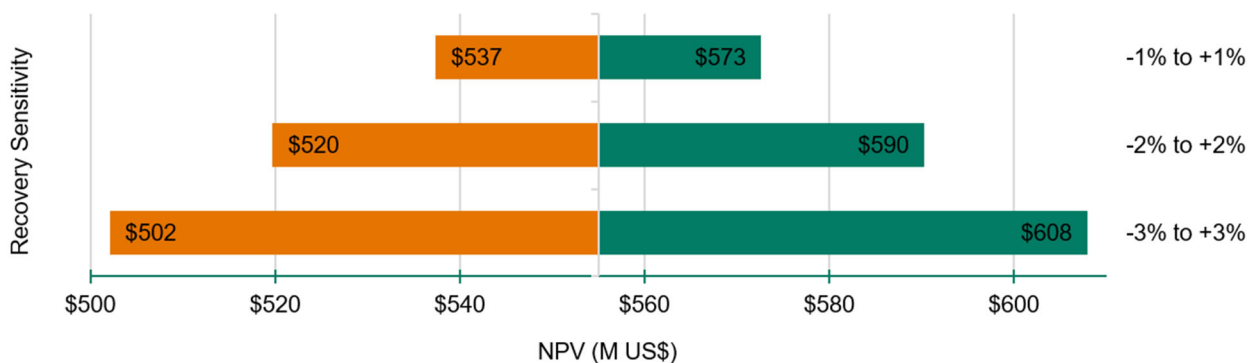

**Figure 22-3: Recovery Sensitivity (Eldorado 2024)**

## 23 Adjacent Properties

None of the adjacent properties are relevant or material to the disclosure in this Technical Report.

## 24 Other Relevant Data and Information

### 24.1 Summary

This section of the Technical Report describes the results of a Preliminary Economic Assessment (PEA) that incorporates additional Mineral Resources from the Triangle and future Ormaque mines (the “**PEA case**”). At Triangle, these Mineral Resources are primarily located deeper than the C5 zone. At Ormaque, these Mineral Resources are primarily located at depth and within lateral extensions of shallower zones. The Mineral Resources discussed in the PEA have not been converted to Mineral Reserves as described in the previous sections of this Technical Report.

The economic analysis for the PEA is primarily based primarily on Inferred Mineral Resources that are considered too speculative geologically to have the economic considerations applied to them to allow for categorization as Mineral Reserves. There is no certainty that the Inferred Mineral Resources will be converted, nor the value of the PEA realized. None of the Mineral Resources described as mineralized material in the PEA coincide with the Mineral Reserves described in the previous sections of this Technical Report.

Production schedules and annualized cash flow tables are presented. The dates shown in the production tables are for illustrative purposes. Additional drilling, mining, and engineering studies may alter the assumptions as discussed in this Technical Report.

The results of the PEA as summarized in this Section represent forward-looking information.

### 24.2 Introduction

This PEA highlights the additional value and potential for extended mine life with the inclusion of Mineral Resources primarily from lower Triangle, as well as deeper resources identified at Ormaque. Production schedules and annualized cash flow tables are presented. The dates shown in the production tables are for illustrative purposes. Additional drilling, mining, and engineering studies may alter the assumptions as discussed in this Technical Report.

The results of the PEA as summarized in this Section represent forward-looking information.

### 24.3 Reliance on Other Experts

Information pertaining to the reliance on other experts for the PEA is provided in Section 3 of this Technical Report.

### 24.4 Property Description and Location

Information pertaining to the property description and location of the Property is provided in Section 4 of this Technical Report.

### 24.5 Accessibility, Climate, Local Resources, Infrastructure and Physiography

Information pertaining to the accessibility, climate, local resources, infrastructure and physiography of the Property is provided in Section 5 of this Technical Report.

## 24.6 History

Information pertaining to the history of the Property is provided in Section 6 of this Technical Report.

## 24.7 Geological Setting and Mineralization

Information pertaining to the geological setting and mineralization of the Property is provided in Section 7 of this Technical Report.

## 24.8 Deposit Type

Information pertaining to the deposit types found on the Property is provided in Section 8 of this Technical Report.

## 24.9 Exploration

Information pertaining to exploration activities on the Property is provided in Section 9 of this Technical Report.

## 24.10 Drilling

Information pertaining to drilling carried out on the Property is provided in Section 10 of this Technical Report.

## 24.11 Sample Preparation, Analyses and Security

Information pertaining to the preparation of samples, analyses carried out, and security procedures employed is provided in Section 11 of this Technical Report.

## 24.12 Data Verification

Information pertaining to the verification of data carried out by the Qualified Persons is provided in Section 12 of this Technical Report.

## 24.13 Mineral Processing and Metallurgical Testing

Details on Mineral Processing and Metallurgical testing can be found in Section 13. During processing of ore from the C5 zone of the Triangle mine in 2024, the ore was observed to be harder than other Triangle ores which had previously been processed. This variation was observed through a minor reduction in throughput and a coarsening of the grind size. A series of samples from C5 and deeper zones in Triangle as well as additional Ormaque veins were sent to SGS for Bond Ball Work Index testing.

The results, as summarized in Table 24-1, indicate that the C5 material is harder than the deeper samples from C6, C7, C8, and C9. Additionally, the three Ormaque veins tested (E020, E030, and E050) were less hard than the C5 material.

**Table 24-1: Bond Ball Mill Work Index Results (75 µm closing screen)**

Composite ID	Hardness Percentile (SGS)	Bond Ball Mill Work Index (kWh/t)	Category
Triangle – C5	78	16.9	Hard
Triangle – C6	61	15.2	Moderately Hard
Triangle – C7	69	15.9	Moderately Hard
Triangle – C8	71	16.1	Moderately Hard
Triangle – C9	62	15.3	Moderately Hard

Composite ID	Hardness Percentile (SGS)	Bond Ball Mill Work Index (kWh/t)	Category
Ormaque – E020	62	15.3	Moderately Hard
Ormaque – E030	62	15.3	Moderately Hard
Ormaque – E050	64	15.5	Moderately Hard

The comminution results indicate that there should be no challenges with attaining the production required for the PEA extended LOM.

## 24.14 Mineral Resource Estimates

The Mineral Resource Estimate for the overall Lamaque Complex is presented in Section 16 of this Technical Report. For the purposes of the PEA, a subset of the total resource, including Inferred Mineral Resources, has been considered. In order to generate a consolidated optimized mine plan, in addition of the Measured and Indicated Mineral Resources from Triangle, Ormaque and Parallel, the Inferred Mineral Resources from the Triangle and Ormaque deposit were considered for subsequent steps. These Mineral Resources are summarized in Table 24-2.

Information pertaining to the key assumptions, parameters and methods used to estimate the Mineral Resources is provided in Section 14 of this Technical Report.

**Table 24-2: Lamaque Complex Mineral Resources**

Mine	Category	Tonnes (× 1000)	Grade Au (g/t)	Contained Au (oz × 1000)
Triangle	Measured + Indicated	5,704	6.58	1,207
	Inferred	7,508	6.52	1,574
Ormaque	Measured + Indicated	1,417	16.42	748
	Inferred	1,749	14.87	837
Parallel	Measured + Indicated	221	9.87	70

Parallel Inferred Mineral Resources have not been considered in the PEA due to the relatively low level of analysis that was completed with regards to their inclusion.

### 24.14.1 Mineable Mineralized Material Summary

The Mineral Resource models were prepared by Eldorado and have an effective data of September 30, 2024. Using the Mineral Resources described in Section 24.14, the same modifying factor and cut-off grades described in Section 1 were applied in order to quantify the amenable mineralized material to mining. A summary of the incremental mineralized material that is amenable to mining and considered in the PEA is found in Table 24-3. The mineralized material used in the PEA are Mineral Resources that have not been converted to Mineral Reserves and are primarily Inferred Mineral Resources.

Table 24-3

Table 24-3: Summary of Incremental Mineralized Material in PEA Case

Mine	Tonnes (× 1000)	Grade Au (g/t)	Contained Au (oz × 1000)
Triangle	4,132	6.11	812
Ormaque	2,962	8.17	778
<b>Total</b>	<b>7,093</b>	<b>7.20</b>	<b>1,642</b>

## 24.15 Mineral Reserve Estimates

No Mineral Reserves are included within the PEA described in this Section.

## 24.16 Mining Methods

### 24.16.1 Introduction

Information pertaining to the mining methods considered within the PEA are as summarized in Section 16 of this Technical Report. The Mineral Resources within the deeper zones at Triangle will continue to be mined with the Longhole open stope method, while the Mineral Resources at Ormaque are expected to be mined with the Drift and Fill method as was done for the recently completed Bulk Sample.

### 24.16.2 Mine Plan

Detailed mine planning parameters and mining method descriptions are provided in Section 16.3 of this Technical Report.

### 24.16.3 Underground Mine Design

Detailed descriptions for the underground mine design are provided in Section 16.4 of this Technical Report.

### 24.16.4 Mine Backfill

Descriptions of the methods used for mine backfill is provided in Section 16.5 of this Technical Report.

### 24.16.5 Productivity Rates

Descriptions of the productivity rates considered is provided in Section 16.5 of this Technical Report.

The mining production rate for the Lamaque Project is based on the operating mining rates, permitting restrictions and the Sigma mill processing throughput of 2,500 tonnes per day (tpd). The hoisting permit for Triangle allows for 2,650 tpd and for Parallel and Ormaque another 2,500 tpd. As Ormaque will be mined using DAF, planned production ranges between 1,000 and 1,300 tpd, which is based on a detailed build-up of mine schedules using Deswik software.

Production rates for longhole mining are based on historic performance at Triangle. Due to increased travel time to workplaces as the mine deepens, the stope mucking production rates were adjusted for lower Triangle zones C6 to C8 and C9 to C10 (refer to Table 22-4).

**Table 24-4: Longhole Mining Mucking Rates**

Mining Zone	Mucking Rate	Effective Mucking Time per Day
Lower Triangle: zones C6 to C8	1,106 tonnes / day	12 hours / day
Lower Triangle: zones C9 to C11	1,022 tonnes / day	11.1 hours / day

## 24.16.6 Mine Development and Production Schedule

All mine development and production scheduling has been completed using Deswik scheduling software. The schedule is interactively linked to the 3D mine model. All development and production scheduling has been based on dependency linking and start date constraints within the mine model. All data is contained within the mine model and schedule.

The differential mineralized material mined between the Mineral Reserves case and the PEA case on an annual basis is summarized in Table 24-5.

**Table 24-5: Incremental Mineralized Material and Waste Rock Annual Summary PEA LOM**

Mined Material	2025	2026	2027	2028	2029	2030	2031	2032	2033	2034	2035	2036	2037	2038	2039	2040	2041	Total
Mineralized Material (kt)	52	25	13	7	338	408	411	501	886	860	870	816	523	431	396	325	232	<b>7,093</b>
Waste Rock (kt)	-61	177	87	415	643	764	620	436	153	381	39	22	12	17	14	26	26	<b>3,771</b>

Note: Recovered and Diluted Tonnes, rounded.

Additional capital and operating development for the PEA case is required to expand production beyond the actual Measured and Indicated Mineral Resource areas. The development schedule for the extended LOM PEA case is summarized in Table 24-6.

**Table 24-6: Incremental Development Schedule PEA LOM**

Development Type	2025	2026	2027	2028	2029	2030	2031	2032	2033	2034	2035	2036	2037	2038	2039	2040	2041	Total
Lateral CAPEX (km)	-0.4	1.7	1.7	3.1	6.2	4.9	5.2	3.7	1.4	3.5	0.3	0.0	0.1	0.0	0.0	0.0	0.0	31.4
Vertical CAPEX (km)	-0.2	0.2	-0.1	0.4	0.3	0.3	0.3	0.2	0.1	0.1	0.2	0.0	0.0	0.0	0.0	0.0	0.0	1.7
Lateral OPEX (km)	-0.9	-0.4	-0.4	2.7	2.9	5.0	4.1	4.0	2.7	3.4	1.1	0.8	0.5	0.7	0.8	0.9	0.9	28.8
<b>Total</b>																		
Development (km)	-1.5	1.5	1.3	6.2	9.4	10.3	9.5	7.9	4.1	7.0	1.5	0.8	0.5	0.8	0.8	0.9	0.9	61.9
Development (kt)	<b>-42</b>	<b>223</b>	<b>123</b>	<b>534</b>	<b>772</b>	<b>865</b>	<b>807</b>	<b>608</b>	<b>259</b>	<b>426</b>	<b>66</b>	<b>37</b>	<b>24</b>	<b>33</b>	<b>34</b>	<b>39</b>	<b>39</b>	<b>4846</b>

The incremental annual production tonnage by deposit for the PEA case is shown in Figure 24-1.

Mine development is optimized for this PEA, and the development and production schedules presented in this section would alter the schedules presented in Section 16. As shown in Figure 24-1, production of mineralized material would occur earlier and offset some of production profiles presented in Section 16.



Note: Tonnes are diluted and recovered

Figure 24-1: Incremental Annual Mine Production Profile PEA LOM (Eldorado 2024)

### 24.16.7 Mine Equipment

The mobile equipment required for development, production, and support services are listed in Table 24-7. The equipment list is based on the current fleet for the upper Triangle operation and has been updated to include the lower Triangle and the satellite deposits Ormaque, Parallel. The maximum equipment and additional equipment are indicated in the table.

Ormaque requires specific equipment to mine low height drifts in ore zones especially for bolting and jumbo drilling. The fleet schedule will leverage the transfer for some equipment from Triangle to Ormaque as the former mining rate will decrease. Major additions for the PEA Case will be jumbos, bolters, scoops and trucks. Since Triangle will maintain a higher mining rate at higher depth compared to the base case, fewer pieces of mobile equipment will be available for transfer to Ormaque.

Table 24-7: Lamaque Complex Mobile Equipment List (PEA Case)

Activity	Type	Model	Current Fleet	Max Fleet PEA Case	Additional Equipment for PEA Case
Development Drilling	1-Boom Jumbo	S1D	1	1	0
	2-Boom Jumbo	M2C	2	2	0
	2-Boom Jumbo	S2C	3	6	3
Ground Support	Bolter	Maclean MEM-928 & MEM975	8	10	2
	Small Section Bolter	Maclean SSB	0	3	3
	Cable Drill	Machine Roger	1	1	0
		CMAC SPLH II	1	1	0
Blasting	Explosive Vehicle	PAUS	1	1	0
		Minecat	1	1	0
		Maclean CS3	1	3	2
Mucking	LHD – 8yd	CAT R1700K	1	1	0
		SDK LH514	3	3	0
		SDK LH515i	2	7	5
		CAT R1700G	3	3	0
	LHD - 11yd	CAT R2900G	3	3	0
Hauling	Haul Truck 30T	CAT AD30	2	2	0
	Haul Truck 45T	CAT AD 45	4	4	0
		SDK TH545I	5	9	4
	Haul Truck 50T	TH550B	2	6	4
Production Drilling	Long Hole	SDK DU-311	1	1	0
		CUBEX (contractor)	3	3	0
Support Vehicles	LHD - 3yd	CAT R1300H	2	3	1
	LHD – 6yd	CAT R1600H	3	3	0
	Block Holer	Maclean BH3	1	1	0
	Scissor Lift	Maclean SL2, SL3	6	11	5
	Telehandler	Manitou / Bobcat	3	3	0
	Flatbed Boom Truck	MacLean BT3	3	4	1
	Grader	CAT MC100	2	3	1
	Blockholer	BH3	2	2	0
	Cement Mixer	MacLean TM3	4	4	0
	Backhoe	CAT420Fit / John Deer 310	4	4	0
	Shotcrete Sprayer	Swatcrete	1	2	1
	Service Truck	CS3	3	3	0
	Mine Rescue	PAUS Minca 18	1	1	0
	Tractor	Kubota	35	38	3
	Jeep	Toyota	24	33	9
Surface Front Loader	Volvo / Neuson / Komatsu / CAT / Yanmar	8	8	0	

### **24.16.8 Ventilation**

Information pertaining to the ventilation system is provided in Section 16.9 of this Technical Report.

### **24.16.9 Geotechnical Assessment**

Information pertaining to the geotechnical assessments carried out is provided in Section 16.10 of this Technical Report.

### **24.16.10 Mine Services**

The Mine Services as described in Section 16.11 of this Technical Report will be extended as required to provide dewatering, compressed air, water, explosives storage, underground power distribution, and underground communications as required.

## **24.17 Recovery Methods**

Recovery methods are described in Section 1 of this Technical Report and would be unchanged with respect to this PEA.

## **24.18 Project Infrastructure**

Additional tailings storage capacity will be required to mine and process the additional Mineral Resources identified in this PEA are described below. All other infrastructure required is discussed in Section 1.

### **24.18.1 Tailings Strategy for PEA**

With the addition of mineralized material from Inferred Mineral Resources, a total of 12.78 Mt of mineralized material will be processed during the extended life of mine. The Sigma TSF has capacity for 2.86 Mt, and approximately 50% of the tailings will be placed underground as cemented paste backfill into the Ormaque and Triangle mines with the addition of the paste plant. With the Sigma TSF reaching capacity in 2029, an additional tailings storage facility will be required with capacity for approximately 5.86 Mt of tailings. With this additional tailings storage facility, Phase 7 of the Sigma TSF would not be completed and the B9 cell would be closed a year earlier.

Studies have been ongoing for alternative options for additional tailings storage. Prefeasibility work has been completed on the reutilization of the historic Lamaque TSF for additional tailings storage and the facility would have sufficient capacity for tailings from processing of mineralized materials identified in this PEA. Studies will continue on the Lamaque TSF as well as alternative studies.

#### **24.18.1.1 Sigma TSF**

The North Basin (Phase 5) will be implemented and used for water management of the Sigma TSF and support water management for an expanded site layout including an additional TSF facility. Phase 7 would not be completed with a focus being placed on a new facility with greater capacity and lower capital intensity. Progressive closure would be completed earlier to reduce the contact water catchment.

The progressive closure of the Sigma TSF for this case would be:

- Cell B1 closure in 2025
- Cell B2 closure in 2026
- Cell B9 closure in 2027
- Cell B4 closure beyond 2029, the cell would remain open as a tailings placement contingency

### 24.18.1.2 Lamaque TSF

Based on long-term planning for the Lamaque Complex, additional capacity will be required in the latter half of 2029. A trade-off study and Prefeasibility study were carried out in 2023 and in early 2024 to identify the long-term requirements for tailings storage that identified the Lamaque TSF as a viable option for the continuation of tailings management for the operation. The findings include:

- The existing dykes must be stabilized to mitigate potential long-term safety and closure concerns regardless of if the Lamaque TSF is used to store tailings or not.
- The stabilization of the dykes of the Lamaque TSF will impact the existing fish habitats at the toes of the TSF, requiring relocation of streams and fish habitats.
- The North Basin of the Sigma TSF can be used to support water management of a recommissioned Lamaque TSF.

Utilization of the west section of the Lamaque TSF will be sufficient for the storage of the tailings created from processing the mineralized material considered in this PEA. The north and eastern sectors of the Lamaque TSF will remain untouched and unimpacted by proposed future operations and these areas are not part of the overall applicable watershed for the design flood. Several simulations have been carried out and the configuration shown in Figure 24-2 for tailings management was developed.

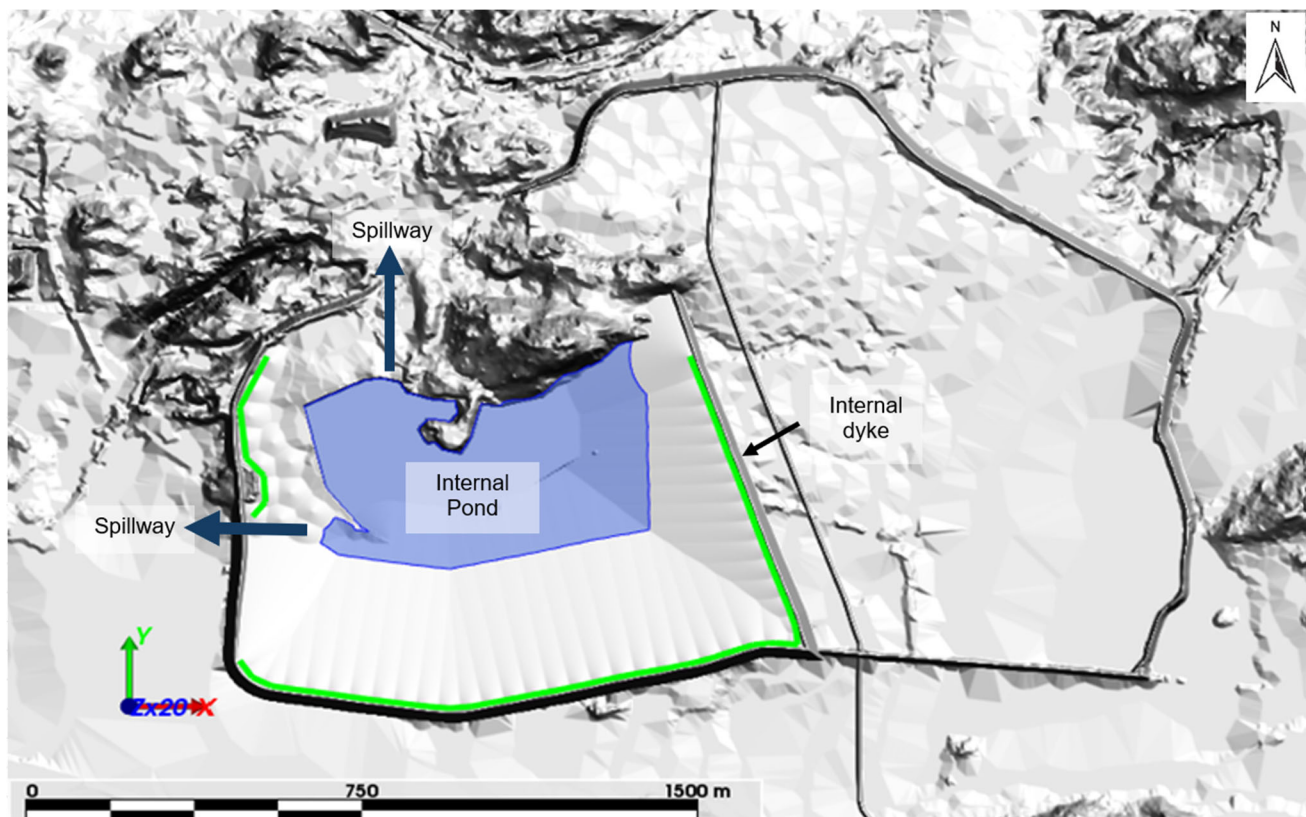

**Figure 24-2: Proposed Lamaque Tailings Storage Facility Plan View (Eldorado 2024)**

Significant dyke raises would be required for this option. Tailings, spigotted from the crest, will push the supernatant pond to the North, toward a natural high point where the emergency spillway can be safely built for discharging water to the environment. This configuration has more than enough capacity for the remaining tailings.

### 24.18.2 Waste Stockpile

Waste stockpiles described in Section 1 will have sufficient capacity for the additional waste rock.

### 24.18.3 Paste Reticulation

The paste reticulation systems in both the Triangle and Ormaque mines would be extended at depth. No additions or changes are required to the paste plant as described in Section 1.

## 24.19 Market Studies and Contracts

Information pertaining to market studies and contracts is provided in Section 0 of this Technical Report.

Commodity prices used for Mineral Resource estimates and the PEA are set by Eldorado at the corporate level. The gold price used for the Mineral Resource estimate was US\$1,800 per oz and a US\$-to-CAD\$ exchange rate of CAD\$1.30. The potentially mineable stope shapes were constrained using a gold price of \$1,450/oz and an US\$-to-CAD\$ exchange rate assumption of CAD\$1.30. The financial analysis for the PEA used a gold price of \$2,000/oz.

## 24.20 Environmental Studies, Permitting and Social or Community Impact

Information provided related to environmental studies, permitting, and social or community impact is provided in Section 1 of this Technical Report. As described in Section 20.1.2.2, the current CoA #1 (7610-08-01-70095-31) already allows for the mining of the Ormaque deposit to a depth of 453 m (corresponding to mining level 12). Additional geochemical, geotechnical, and hydrogeological characterization studies are being carried out to extend the permit to depths beyond 453 m, as required for the PEA.

## 24.21 Capital and Operating Costs

The capital and operating cost estimates presented in this PEA are based on conceptual estimates as required to mine the additional Mineral Resources identified within the Triangle and Ormaque deposits.

All capital and operating costs in this report are United States Dollars (US\$) unless stated otherwise.

The capital cost estimate required for mining and processing the mineralized material within the PEA is effective Q4 2024 and expressed in constant dollars. The capital costs required for the PEA are incremental to the capital costs described in Section 1 which pertain to the Mineral Reserves.

The capital cost consists of \$32.5 M in growth capital and \$424.3 M in sustaining capital, as summarized in Table 24-8 for the extended life of mine for the PEA case. Negative costs within the growth capital line items reflect a transfer from growth to sustaining capital for some of the items within the PEA compared to the Mineral Reserves case.

**Table 24-8: Capital Cost Estimate**

Description	Growth (\$M)	Sustaining (\$M)	Total (\$M)
Mining	(2.1)	375.4	373.4
Processing	11.1	3.9	15.0
General and Administration	(0.3)	22.6	22.3
Infrastructure	0.0	0.0	0.0
Exploration and Delineation Drilling	23.8	18.0	41.8
Closure	0.0	4.4	4.4

Description	Growth (\$M)	Sustaining (\$M)	Total (\$M)
Salvage (credit)	0.0	0.0	0.0
<b>Total</b>	<b>32.5</b>	<b>424.3</b>	<b>456.8</b>

### 24.21.1 Type and Class of Cost Estimate

The capital cost estimate pertaining to the PEA is at a conceptual level. The estimate meets the definition of an AACE Class 5 estimate. The accuracy of the capital cost estimate developed for the Mineral Reserve qualified as -30% / +50%.

### 24.21.2 Cost Basis, Labour and Productivity

Costs, labour and productivity assumptions are based on current development mining rates, recent tailings construction projects carried out at the Sigma TSF, and ongoing projects that were carried out at the Sigma mill in recent years.

### 24.21.3 Growth Capital

Growth capital required for the purposes of the PEA totals \$32.5 M, see Table 24-9.

**Table 24-9: Growth Capital Items, PEA Case**

Description	Years	Total (\$M)
Ormaque Mine Infrastructure	2025 – 2029	(2.1)
Sigma TSF Expansion	2027 – 2028	(20.7)
Lamaque TSF Development	2026 – 2033	31.8
Exploration	2025 – 2036	23.8
General and Administration	2025 – 2026	(0.3)
<b>Total</b>		<b>32.5</b>

#### Mine Infrastructure

A portion of the future Ormaque mine infrastructure would be deferred in the PEA case. The costs presented are the additional costs for development regarding Mineralized Material, but some costs classified as growth capital described in Section 1 would be reclassified as sustaining capital for financial reporting purposes. The negative value reported in Table 24-9 above are now reported as sustaining capital in Table 24-10 for the PEA case.

#### Tailings

Phase 7 for the Sigma TSF would not be executed in the PEA case as there would be insufficient tailings storage space for the extended life of mine as described in 24.18.1.1.

After stabilization of the Lamaque TSF, the facility would be developed to store the additional tailings that would be generated through the extended life of mine.

There is a net increase in growth capital associated with tailings storage for the PEA case.

#### Exploration

Exploration costs are for budgeted annual drilling programs.

#### General and Administration

A small portion of the general and administrative capital cost has been reclassified from growth capital to sustaining capital.

## 24.21.4 Sustaining Capital

Sustaining capital required for the PEA case totals \$424.3 M, see Table 24-10.

**Table 24-10: Sustaining Capital Items**

Description	Years	Total (\$M)
Mining	2025 – 2041	375.4
Processing	2025 – 2040	3.9
General & Administrative	2025 – 2040	22.6
Exploration	2025 – 2036	18.0
Closure	2042 – 2043	4.4
<b>Total</b>		<b>424.3</b>

### Mining

Underground construction includes the following elements that were estimated based on the recent history of underground construction at Triangle:

- Development drifts and stope access
- Dewatering systems and sump pits
- Electrical supply, substations, and U/G power distribution
- Explosives and detonator storage
- Oil, grease, and lubricant storage
- Used and clean water pits
- Ore raises and chutes
- Secondary ventilation equipment, ventilation doors and walls
- Refuges and dining rooms
- Mobile Equipment

The sustaining capital portion of mobile equipment covers the replacement and major overhauls of currently operating mobile equipment and is based on the fleet requirements defined by the mine plan developed during this study.

### General and Administration

General & Administrative sustaining capital are budgeted costs supporting the sustaining capital mining costs. Costs include reclassification of growth capital to sustaining capital.

### Processing

Costs are associated with ongoing energy efficiency programs and other small improvement programs.

### Exploration

Sustaining exploration is for delineation drilling, the estimate was developed by Eldorado and reflects the current delineation drilling plan and is priced from the current drilling costs at the Lamaque operation.

### Closure

The closure cost is presented is for the additional costs associated with closing the Lamaque TSF required for the additional tailings processed in the PEA case.

### 24.21.5 PEA Operating Costs

The average operating cost for mining and processing the mineralized material in the PEA over the extended life of mine is estimated to be \$180.02/t of ore or \$851.47/oz Au. Table 24-11 provides the breakdown of the projected operating costs for the PEA case.

**Table 24-11: Operating Cost Summary**

Cost Area	Average cost (\$/tonne ore)	Average cost (\$/oz Au)
Underground Mining	128.74	608.91
Processing	26.24	124.10
General and Administration	25.04	118.46
<b>Total</b>	<b>180.02</b>	<b>851.47</b>

#### 24.21.5.1 PEA Case Basis of Operating Cost Estimate

The operating cost estimate for the PEA is based on operating data through Q4 2024 and is considered to be near feasibility level accuracy, supported by the actual operating costs from the last six years of production.

The operating cost estimate is based on the mine scheduled tonnage per period that was produced by Eldorado.

No cost escalation (or de-escalation) was assumed. The transport and handling of doré from the mill was excluded from the operating cost estimate but included in financial modelling.

#### 24.21.5.2 Mine Operating Cost

The mine unit operating costs were calculated over the total ore mined from development and production. The unit cost is \$128.74/t of ore.

Triangle mining cost averages \$99.16 per tonne in the extended LOM and Ormaque mining costs average \$170.00 per tonne in the extended LOM.

Mining operating costs consist primarily of wages, fuel, electric power, consumables, and equipment maintenance. All level development, except for development detailed in the capital cost section, has been allocated to the operating cost.

#### 24.21.5.3 Process Operating Costs

Processing costs include reagents, grinding media, plant maintenance materials, vehicle fuel and maintenance, laboratory services, energy (electricity and natural gas), and manpower required for operation of the Sigma mill. Milling costs for an approximate average production rate of 920 ktpa are estimated at an average of \$26.24/t. Unit prices for reagent and grinding media were taken from ongoing operations at the Sigma mill.

Maintenance materials were estimated per major equipment based on experience, with allowances added for general materials and per plant area for lubricants and miscellaneous mechanical, piping, electrical and instrumentation materials.

Maintenance and fuel costs for plant mobile vehicles have also been included. Electricity costs were calculated based on Hydro Québec's current rate. The natural gas cost for heating was estimated based on current rates.

#### 24.21.5.4 General and Administration Operating Costs

The unit cost for General and Administrative costs averages \$25.04/t mined, including administration, finance, environmental, and health and safety departments.

### 24.22 Economic Analysis

#### 24.22.1 Summary

The PEA supporting the extended LOM through inclusion of additional Mineral Resources at Triangle and Ormaque indicates an additional after-tax NPV of US\$623 M at a discount rate of 5%.

The models were subjected to sensitivity analyses to determine the effects of changing metal prices, capital, and operating expenditures on financial returns.

All costs, revenues and prices are in US\$ unless otherwise noted.

The PEA supporting the Triangle and Ormaque Mineral Resources considers the potential economic viability of an optimized mined plan, including Mineral Resources from Ormaque and Triangle deposits and all additional CAPEX necessary to support such plan. The economic model presents processing mineralized material not included in the Mineral Reserves described in previous sections of the Technical Report. Economics are the incremental cashflows generated from the mineralized material.

The PEA should be differentiated from the economic analysis carried out on the Mineral Reserves. The PEA is preliminary in nature, based on numerous assumptions and the incorporation of Inferred Mineral Resources only demonstrates the potential viability of Mineral Resources that are not Mineral Reserves, and are not as comprehensive as the economic analysis on the Mineral Reserves. The level of detail, precision, and confidence in outcomes between the economic analysis for the Mineral Reserves and the PEAs is significantly different.

#### 24.22.2 Preliminary Economic Analysis (PEA)

The PEA was carried out using a discounted cash flow approach on a pre-tax and after-tax basis. No provision was made for the effects of inflation. Current Canadian tax regulations were applied to assess the corporate income tax liabilities, while the regulations in Québec were applied to assess the mining duties and income tax liabilities.

All costs, revenues and prices are in US\$ unless otherwise noted.

The Triangle and Ormaque Inferred Mineralized Material are mainly located in the lower zones of both Ormaque and Triangle deposits.

This PEA is preliminary in nature and is based on numerous assumptions and the incorporation of Mineral Resources that are not Mineral Reserves. Inferred Mineral Resources are considered too speculative geologically to have economic considerations applied to them that would enable them to be categorized as mineral reserves except as allowed for by NI 43-101 in PEA studies. There is no guarantee that the Inferred Mineral Resources can be converted to Indicated or Measured Mineral Resources and, as such, there is no guarantee that the economics described herein will be achieved. Mineral Resources that are not Mineral Reserves do not have demonstrated economic viability.

The economic analysis presented in this section contains forward-looking information regarding the mineral resource estimates, commodity prices, exchange rates, proposed mine production plan, projected recovery rates, estimation, and realization of mineral resources, estimated costs and timing of capital, sustaining and operating expenditures, construction costs, closure costs and requirements, and schedule. The results of the

economic analysis are subject to several known and unknown risks, uncertainties, and other factors that may cause actual results to differ materially from those presented here.

Additional risks to the forward looking information include:

- Changes to costs of production from what are estimated.
- Unrecognized environmental and social risks.
- Unanticipated reclamation expenses.
- Unexpected variations in quantity of mineralized material, grade, or recovery rates.
- Geotechnical or hydrogeological considerations during mining differing from assumed.
- Failure of mining methods to operate as anticipated.
- Failure of plant, equipment, or processes to operate as anticipated.
- Changes to assumptions as to the availability of electrical power, and the power rates used in the operating cost estimates and financial analysis.
- Ability to maintain the social licence to operate.
- Accidents, labour disputes and other risks of the mining industry.
- Changes to interest rates.
- Changes to tax rates and incentive programs.

The economic analysis evaluates revenue, expenditures, taxes, and other factors applicable to the Project. The economic analysis was performed using the following assumptions and basis:

- The economic analysis is based on processing and recovery methods, mining methods and production schedule as outlined in previous sections.
- The gold price used in the economic model is \$2,000/oz. No price inflation or escalation factors were considered. It is understood that commodity prices can be volatile and that there is the potential for deviation from the LOM forecasts.
- Class specific Capital Cost Allowance rates are used for the purpose of determining the allowable taxable income.
- Production capacity averaging 935 ktpa through to 2032, with production then tapering off until 2041.
- Class specific Capital Cost Allowance rates are used for the purpose of determining the allowable taxable income.
- An exchange rate of CAD\$1.30 per US\$1.00 was assumed to convert operating and capital costs in CAD\$ into US\$.

This financial analysis was performed on both a pre-tax basis and after-tax. The general assumptions used for this financial model are summarized in Table 24-12.

**Table 24-12: PEA Financial Model Parameters**

Parameter	Unit	Value <sup>(1)</sup>
Gold Price	\$/oz Au	2,000
Total Material Mined (Mineralized Material and Waste)	Mt	10.86
Total Material Processed	Mt	7.09
Gold Recovery (average)	%	97.0%
Average Mining Costs	\$/t ore	128.74
Average Process Costs	\$/t	26.24
Average General and Administrative Costs	\$/t	25.04
Total Operating Cost	\$/t	180.02
Transport and Refining (net of silver credit)	\$/t	2.00
Growth Capital Cost	\$ M	32.5

Parameter	Unit	Value <sup>(1)</sup>
Sustaining Capital Cost	\$ M	419.9
Reclamation and Closure Cost	\$ M	4.4

All capital costs (expansion, sustaining, reclamation and closure) for the PEA have been distributed against the development schedule to support the economic cash flow model.

For the purposes of this financial analysis, additional reclamation, and closure costs of \$4.4 M have been assumed. No additional salvage value has been assumed.

Eldorado is the 100% owner of the Lamaque property. For purposes of the economic analysis, a royalty rate of 1.0% has been applied to all commercial ounces. An insignificant portion of the Triangle Mineral Resources are in the Roc d'Or east extension block, which is subject to a 2% royalty, the remainder of the Lamaque Property being subject to the aforementioned 1.0% royalty including all Ormaque Mineral Resources.

The Lamaque Complex is subject to three levels of taxation, including federal income tax, provincial income tax, and provincial mining taxes, the taxes as summarized in Section 22.1 are applicable to the PEA case.

There are no other interests regarding the Property.

Over the extended PEA life of mine, an additional 7.11 Mt of mineralized material will be mined. Figure 24-3 provides a summary of mining production by deposit.

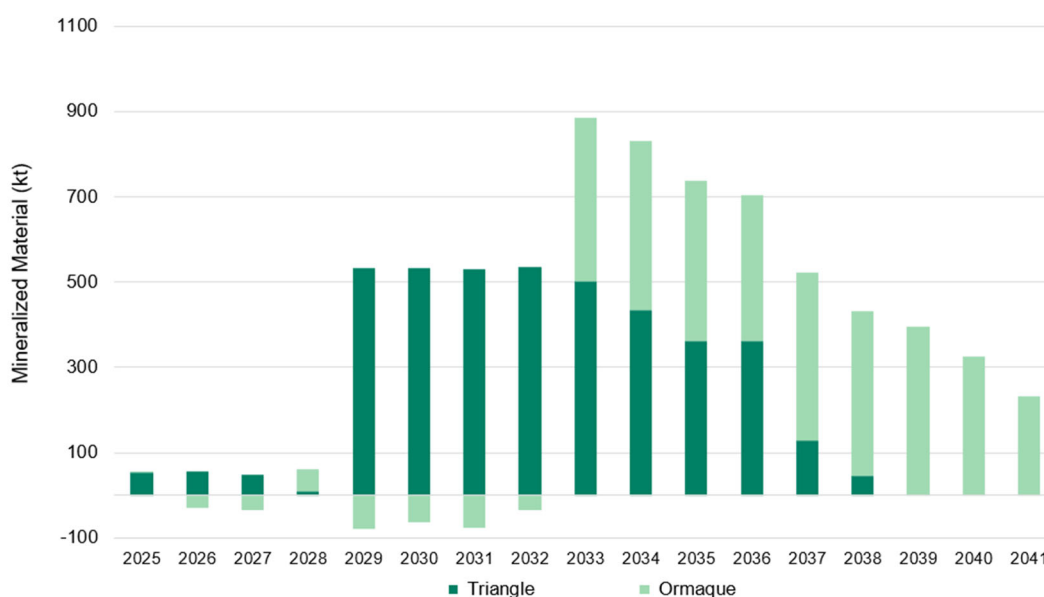

**Figure 24-3: Annual Mineralized Material Mined by Deposit, PEA Case (Eldorado 2024)**

The mine production plan shown accounts for the inclusion of Mineral Resources (mineralized material) in an optimized PEA mine plan. Production from Ormaque mining operations would be slightly reduced showing negative values in early years with additional production coming from the Triangle mine.

A 5% discount rate was applied to the PEA cash flows to derive the NPV on a pre-tax and after-tax basis utilizing mid-year discounting convention. Cash flows have been discounted to Q4 2024. The summary of the financial evaluation results for the PEA are presented in Table 24-13.

Table 24-13: PEA Financial Analysis Summary

Description		Unit	Value
Pre-Tax	Net Cash Flow	\$M	1,232.7
	Net Present Value (@ 5% discount)	\$M	712.9
After-Tax	Net Cash Flow	\$M	1,085.1
	Net Present Value (@ 5% discount)	\$M	623.1

For clarification, the financial results for the PEA are incremental to the financial analysis carried out on the Mineral Reserves in Section 1. Capital expenditures are part of ongoing operational development funded by ongoing gold sales and there are no external funding requirements. The IRR for the PEA is 43.5% .

Tonnages, grade, and mill recoveries shown are incremental values between an optimized PEA case and the Mineral Reserves case, fluctuations in recoveries and grade reflect shifts in production plan. The average head grade for the mineralized material is 6.76 g/t, the average recovery for the mineralized material is 97%.

A summary of the cash flow model for the PEA is presented in Table 24-14.

Table 24-14: PEA Cash Flow Model

Parameter	Year	Total	2025	2026	2027	2028	2029	2030	2031	2032	2033	2034	2035	2036	2037	2038	2039	2040	2041	2042	2043
<b>Production Summary</b>																					
Total Tonnes Mined	kt	7,093	52	25	13	7	338	408	411	501	886	860	870	816	523	431	396	325	232	0	0
Total Material Processed	kt	7,093	65	10	35	35	288	410	411	501	886	860	870	816	523	431	396	325	232	0	0
Mill Gold Head Grade	g/t Au	6.78	0.48	23.41	0.20	3.81	4.38	4.18	5.97	4.92	7.18	7.62	7.27	7.66	7.46	7.98	7.86	7.24	6.46	0.00	0.00
Mill Gold Recovery	%	97.0%	97.0%	97.0%	97.0%	101.8%	98.1%	97.4%	97.2%	97.0%	97.0%	96.9%	96.7%	96.8%	97.0%	97.0%	97.0%	97.0%	97.0%	0.0%	0.0%
Gold Production	koz Au	1,500	1.0	7.3	0.2	4.4	39.8	53.6	76.7	76.9	198.2	204.1	196.9	194.5	121.8	107.2	97.1	73.4	46.7	0.0	0.0
<b>Revenue</b>																					
Gold Sales	US\$M	2,999	2.0	14.6	0.4	8.7	79.7	107.2	153.3	153.7	396.4	408.3	393.7	389.1	243.6	214.4	194.1	146.8	93.3	0.0	0.0
Transport & Refining Cost	US\$M	3	0.0	0.0	0.0	0.0	0.1	0.1	0.2	0.2	0.4	0.4	0.4	0.4	0.2	0.2	0.2	0.1	0.1	0.0	0.0
Royalty Payments	US\$M	30	0.0	0.1	0.0	0.1	0.8	1.1	1.5	1.5	4.0	4.1	3.9	3.9	2.4	2.1	1.9	1.5	0.9	0.0	0.0
<b>Net Revenue</b>	<b>US\$M</b>	<b>2,966</b>	<b>2.0</b>	<b>14.4</b>	<b>0.4</b>	<b>8.6</b>	<b>78.8</b>	<b>106.0</b>	<b>151.7</b>	<b>152.0</b>	<b>392.0</b>	<b>403.8</b>	<b>389.4</b>	<b>384.8</b>	<b>240.9</b>	<b>212.0</b>	<b>192.0</b>	<b>145.2</b>	<b>92.3</b>	<b>0.0</b>	<b>0.0</b>
<b>Operating Expenditures</b>																					
Mining	US\$M	913	0.2	0.3	-8.1	10.4	27.2	51.0	37.2	49.5	111.9	109.8	110.8	102.8	78.7	69.6	67.3	55.3	39.4	0.0	0.0
Processing	US\$M	186	1.5	0.2	0.8	0.8	6.8	9.7	9.7	11.9	23.0	22.4	22.6	21.3	14.4	12.2	11.4	9.7	7.5	0.0	0.0
General & Administration	US\$M	178	0.0	0.0	0.0	0.0	2.4	3.4	2.9	5.0	22.1	19.1	20.3	20.4	18.0	18.0	18.0	18.0	10.0	0.0	0.0
<b>Operating Costs</b>	<b>US\$M</b>	<b>1,277</b>	<b>1.7</b>	<b>0.5</b>	<b>-7.3</b>	<b>11.3</b>	<b>36.5</b>	<b>64.1</b>	<b>49.8</b>	<b>66.3</b>	<b>157.0</b>	<b>151.3</b>	<b>153.7</b>	<b>144.6</b>	<b>111.1</b>	<b>99.8</b>	<b>96.7</b>	<b>83.0</b>	<b>56.9</b>	<b>0.0</b>	<b>0.0</b>
<b>Earnings</b>																					
EBITDA	US\$M	1,689	0.2	13.9	7.7	-2.6	42.3	41.9	101.8	85.7	235.0	252.5	235.7	240.2	129.8	112.2	95.3	62.2	35.4	0.0	0.0
<b>Capital Expenditures</b>																					
Growth	US\$M	32	-7.5	-1.6	-8.2	20.3	0.0	4.7	3.1	4.1	7.1	3.5	3.5	3.5	0.0	0.0	0.0	0.0	0.0	0.0	0.0
Sustaining	US\$M	420	7.6	20.9	19.2	40.3	67.1	58.6	59.6	47.5	26.7	37.0	15.6	11.4	3.8	2.0	1.4	1.1	0.1	0.0	0.0
Reclamation and Closure	US\$M	4	0.0	0.0	0.0	0.0	0.0	0.0	0.0	0.0	-5.9	-5.9	0.0	0.0	0.0	0.0	0.0	0.0	0.0	8.1	8.1
Salvage Value Credit	US\$M	0	0.0	0.0	0.0	0.0	0.0	0.0	0.0	0.0	0.0	3.0	0.0	0.0	0.0	0.0	0.0	0.0	0.0	0.0	-3.0
<b>Total Capital Costs</b>	<b>US\$M</b>	<b>457</b>	<b>0.0</b>	<b>19.3</b>	<b>11.0</b>	<b>60.6</b>	<b>67.1</b>	<b>63.3</b>	<b>62.7</b>	<b>51.6</b>	<b>27.9</b>	<b>37.6</b>	<b>19.1</b>	<b>14.9</b>	<b>3.8</b>	<b>2.0</b>	<b>1.4</b>	<b>1.1</b>	<b>0.1</b>	<b>8.1</b>	<b>5.1</b>
<b>Pre-Tax Cash Flow</b>																					
Pre-Tax Cash Flow	US\$M	1,233	0.2	-5.3	-3.3	-63.2	-24.8	-21.4	39.1	34.1	207.1	214.9	216.6	225.3	126.0	110.2	93.9	61.1	35.3	-8.1	-5.1
<b>Cumulative Pre-Tax Cash Flow</b>	<b>US\$M</b>	<b>1,233</b>	<b>0.2</b>	<b>-5.2</b>	<b>-8.4</b>	<b>-71.6</b>	<b>-96.4</b>	<b>-117.8</b>	<b>-78.7</b>	<b>-44.6</b>	<b>162.5</b>	<b>377.5</b>	<b>594.1</b>	<b>819.4</b>	<b>945.4</b>	<b>1055.6</b>	<b>1149.4</b>	<b>1210.6</b>	<b>1245.9</b>	<b>1237.8</b>	<b>1232.7</b>
<b>Taxes and Duties</b>																					
Income Tax & Québec Mining Duties	US\$M	148	0.0	1.2	0.2	-3.8	0.9	-0.3	7.6	5.2	21.4	25.8	25.2	28.0	11.7	10.2	8.6	4.8	1.0	0.0	0.0
<b>After-Tax Cash Flow</b>																					
After-Tax Cash Flow	US\$M	1,085	0.1	-6.5	-3.4	-59.4	-25.7	-21.0	31.5	28.9	185.7	189.1	191.4	197.3	114.3	99.9	85.3	56.3	34.4	-8.1	-5.1
<b>Cumulative Cash Flow</b>	<b>US\$M</b>	<b>1,085</b>	<b>0.1</b>	<b>-6.4</b>	<b>-9.8</b>	<b>-69.2</b>	<b>-94.9</b>	<b>-116.0</b>	<b>-84.4</b>	<b>-55.5</b>	<b>130.2</b>	<b>319.4</b>	<b>510.8</b>	<b>708.1</b>	<b>822.4</b>	<b>922.3</b>	<b>1007.6</b>	<b>1063.9</b>	<b>1098.3</b>	<b>1090.2</b>	<b>1085.1</b>

A summary of the PEA production costs is provided in Table 24-15. Total cash costs are calculated per ounce on a payable basis using the costs of mining, processing, on-site G&A, refining and transport, and royalties.

The PEA extended LOM operating cash cost per ounce is \$853/oz Au.

The LOM all-in sustaining cost (AISC) per ounce is \$1,156/oz Au derived from the total cash costs plus sustaining capital, and closure costs.

**Table 24-15: PEA Production Cost Summary**

Description	Unit	Value
Gold Production	koz	1,500
Mining Costs	\$ M	913
Processing Cost	\$ M	186
General & Administration Costs	\$ M	178
Refining and Transport	\$ M	3.0
Royalties	\$ M	30
Total operating cost	\$ M	1,310
Gold price	\$/oz	2,000
Cash cost (operating)	\$/oz	853
Sustaining and closure costs (net of salvage value)	\$ M	424
Total costs (operating and sustaining)	\$ M	1,734
AISC costs <sup>(1)</sup>	US\$/oz	1,156

**Note:** As defined by the World Gold Council less corporate G&A cost

### 24.22.3 PEA Case Sensitivity Analysis

A financial sensitivity analysis was carried out on the PEA with respect to the gold price, growth capital, sustaining capital, and operating costs. The NPV, after tax at a 5% discount rate, based on the sensitivity analysis are summarized in Table 24-16.

**Table 24-16: PEA Sensitivity Analysis (5%) Sensitivity Results (after-tax)**

Sensitivity	Growth Capital	Sustaining Capital	Operating Cost	Gold Price
% change	NPV\$M	NPV\$M	NPV\$M	NPV\$M
-20%	627	687	780	255
-15%	626	671	740	347
-10%	625	655	701	439
-5%	624	639	662	531
<b>Base</b>	<b>623</b>	<b>623</b>	<b>623</b>	<b>623</b>
5%	622	607	584	715
10%	621	591	545	807
15%	620	575	506	899
20%	619	559	467	991

The sensitivity analysis reveals that the NPV was most impacted by changes to gold price. The gold price was evaluated between \$1,600/oz Au and \$2,400/oz Au. At \$1,600 /oz Au, the Project economics remained robust with an after tax of NPV of \$255 M shown in Figure 24-4.

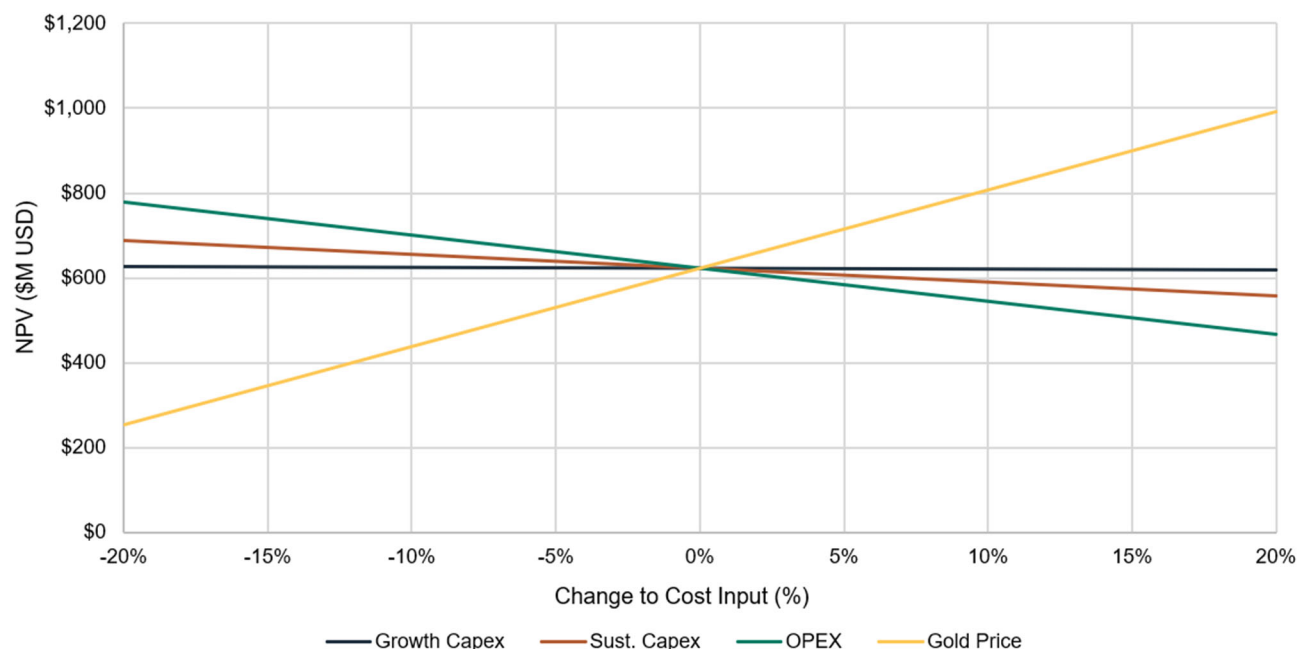

**Figure 24-4: PEA Sensitivity of the Net Present Value (5% discount rate, after-tax) to Gold Price (Eldorado 2024)**

Separately, sensitivities were run with a  $\pm 20\%$  variation range in capital costs, sustaining cost, and operating costs. The analysis showed the Project is most sensitive to operating costs, where a 20% increase resulted in an after-tax NPV of \$467 M. Growth and sustaining capital cost increases were less significant, as shown in Section 1.

## 24.23 Adjacent Properties

There are no adjacent properties as described in Section 1 of this Technical Report.

## 24.24 Interpretation and Conclusions

Using the assumptions and parameters detailed for the 2024 PEA, the conceptual economic analysis returns positive economics. The sensitivity analysis indicates the Project has a high sensitivity to the gold price, although economics would remain robust at gold prices considerably below the current spot price.

Through the addition of additional Mineral Resources, which are primarily Inferred Mineral Resources located deeper in the Triangle and Ormaque deposits, significant value is demonstrated for the Lamaque Complex.

## 24.25 Life of Asset Strategy

Eldorado endeavours to maximize the value of the Lamaque Project by adding to its existing resource base and by converting resources to reserves, thereby extending mine life and gold production.

Following the modernization of the Sigma mill and the commencement of mining from the Triangle deposit, Eldorado has continued to invest strategically at Lamaque. These investments include the recent development into the Ormaque deposit and bulk sampling campaign. Several exploration targets lie in proximity to the decline, from which exploration drilling will be possible. Eldorado has also

significantly expanded its landholdings in the Abitibi region through the acquisition of QMX Gold Corporation and its Bourlamaque property in 2021.

As part of an overall growth strategy in the Abitibi area, Eldorado continues to evaluate exploration and corporate development opportunities for high-grade ore that could be mined and trucked to the Sigma mill. Bulk mining opportunities that would entail upgrading the Sigma mill to its permitted capacity of 5,000 tpd are also being explored as part of Eldorado's growth strategy for the Abitibi area.

### 24.25.1 Exploration Upside

Despite the long exploration and mining history in the Val-d'Or area, several significant discoveries in the last decade highlight the outstanding mineral potential remaining and the opportunity for additional new discoveries to be made through systematic modern exploration. Eldorado's landholdings at the Lamaque Project and the newly acquired Bourlamaque property contain numerous known mineral occurrences at early to advanced stages of exploration, as well as underexplored areas with highly prospective geology still at the targeting stage. Table 24-17 and Figure 24-5 summarize the more significant mineralized zones and mineral occurrences currently known within the landholdings that are not included in the mineral resources outlined in this study.

The Val-d'Or district and greater southern Abitibi Greenstone Belt is host to a variety of different gold deposit styles. Analogous targets are possible on Eldorado's current land package and include different types of orogenic vein deposit, as well as the potential for gold-rich volcanic massive sulfide (VMS) systems (Table 24-1).

Shear-hosted quartz-tourmaline-carbonate veins are the most common deposit style and key examples include the past producing mines at Lamaque and Sigma. These deposits typically form at the intersection of second- and third-order shear zones and lithological contacts that have contrasting competency, such as volcanic and syn-volcanic intrusive contacts (Sigma) or late intrusive plugs (Lamaque and Triangle).

Examples of shear-hosted vein targets on the property include extensions to known vein systems at Triangle, Sigma and Lamaque, near-mine targets such as Vein No. 6 and Sixteen Zone. On the Bourlamaque property, shear-hosted vein targets include extensions to past producing mines at Lac Herbin, Dumont, Ferderber, Bevcon, and Bufadisson. Similar style targets are also recognized on non-adjacent licenses that are within trucking distance of the Sigma plant and include Bruell and Uniacke-Perestroika. The Sigma Nord target in the northern part of the Lamaque Project area is characterized by shear hosted veins that occur partly within ultramafic rocks and may represent a similar target style to Wesdome's Kiena mine (Athurion et al., 2021).

Flat extension vein systems form another style of orogenic gold deposit that also develop at the intersection of shear zones and lithological contacts. The corridor defined by Parallel-Ormaque-Fortune intersection is very favorable for this style of mineralization and appear to relate to the reactivation of splays of the Manitou shear zone, where the intersection intersects contacts of the C-porphyry. Along-strike and depth extensions of these known zones are high priority exploration targets, as well as to the south towards Mine No. 3 and to the north towards Plug No. 5 and Mine No. 2, the latter being a historic example of mined flat extension veins.

Stockwork style orogenic vein systems represent a bulk tonnage style target. These deposits typically form in late plugs and dykes and are characterized by zones of intense stockwork veins and veinlets. Analogous current and past producing mines include Agnico Eagle's Goldex mine west of Val-d'Or and significant portions of the historic Lamaque mine. Current exploration targets of this type include Triangle

stockworks deeper in Triangle, Plug No. 4, and Bonnefond. All three have exploration upside and offer synergies for higher throughput at the Sigma mill.

The Lamaque Project area and Bourlamaque region is also highly prospective for gold-rich VMS deposits. This type of deposit is not compatible with the Sigma processing plant but nonetheless is an attractive stand-alone target given that two of the world’s largest gold-rich VMS deposits are located in the southern Abitibi (Horne and LaRonde Penna; Dube and Mercier-Langevin, 2021). Sulfide-rich gold mineralization is recognized at the Aumaque occurrence in the Lamaque Project area, whilst historic base and precious metal mines at Manitou-Barvue and Louvicourt occur in stratigraphy that is prospective for VMS deposits in the Bourlamaque region.

Eldorado’s existing land package and joint-venture projects as well as additional corporate development business opportunities provide a foundation for further exploration success in the region. New gravity and magnetic geophysical surveys and modern prospectivity approaches combined with compilation of all the existing historical data for the region will help define additional new targets providing a long-term exploration pipeline for the Lamaque Project.

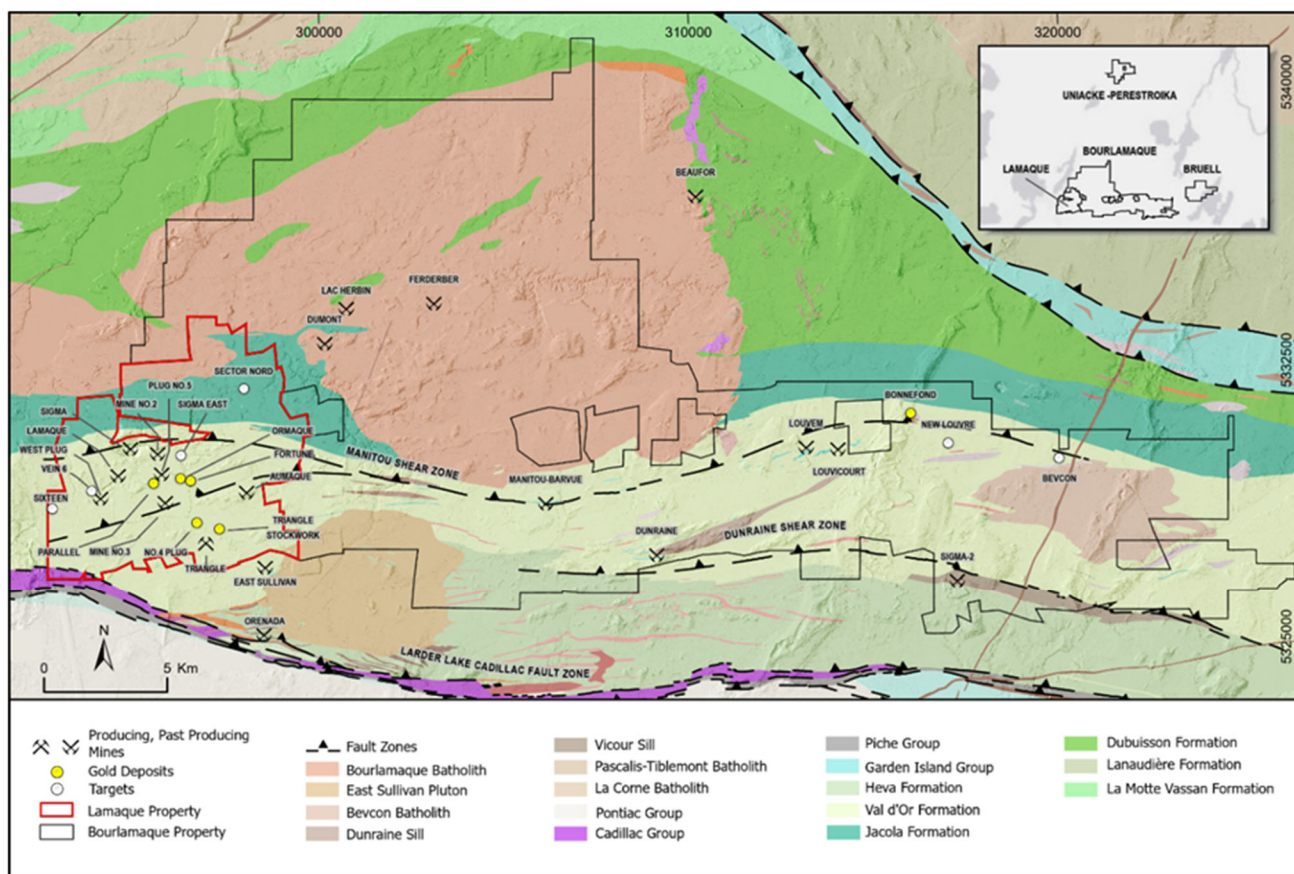

**Figure 24-5: Mineral Occurrences within the Lamaque Property and Bourlamaque Property (Eldorado 2024)**

**Table 24-17: Mineral Occurrences within the Lamaque Property and Bourlamaque Property**

Mineral Occurrence or Target	Exploration Stage	Description
<b>Lamaque Project Area</b>		
Triangle Stockwork	Advanced	Broad zones with high density of quartz-tourmaline-carbonate extensional veins and stockworks; envelopes parts of shear veins deeper in Triangle deposit
Parallel-Ormaque-Fortune	Early to advanced	Extension to the east of the structural corridor hosting the Lamaque deposit. Gold-bearing quartz-tourmaline veins occur as shear-hosted veins close to the Lamaque mine but are mostly extensional sub-horizontal veins near the eastern boundary of the C Porphyry. Ormaque deposit is open at depth and towards the east representing, along with the Fortune area, excellent exploration potential to grow the resources in the Project area.
Vein No. 6	Early	Western extensions of shear-hosted veins from the Lamaque deposit.
Sigma Nord	Early	East-west striking deformation zone along a series of mafic-ultramafic volcanic sequence from the Jacola Formation.
Aumaque	Early	Sulphide-rich gold bearing stringer zones within upper Val-d'Or Formation volcanic rocks.
Mine No. 3	Early	Extensions of historically mined shear-hosted veins. Potential for flat-extensional vein clusters near contact between C porphyry and volcanic units.
Sigma East	Early	Eastern extension of the mineralized shear zones hosting the Sigma deposit. Several high-grade gold-bearing quartz-tourmaline veins hosted identified within sub-vertical shear zones.
West Plug Area	Early	Southwestern extensions of the shear zone hosted quartz-tourmaline veins from the Lamaque deposit.
Plug No. 5	Early	Potential at depth for intrusion-hosted vein clusters and stockwork zones similar to the Lamaque deposit.
Sixteen	Early	Quartz-tourmaline veins and veinlets hosted within an east-west striking dioritic dyke.
<b>Bourlamaque Property</b>		
Herbin	Early	Extensions of the gold-bearing shear zones hosting the deposits mined at Lac Herbin, Federber and Dumont historical mines.
Bourlamaque Batholith	Targeting	Previous exploration in large batholith mainly focused near historic mines. Several sub-parallel structures have been identified and remain to be tested by drilling.
Bonnefond	Advanced	Intrusion-hosted vein stockwork and disseminated style mineralization. Shear-hosted veins have potential for higher grade gold mineralization.
Bevcon/ Buffadison	Early	Extensions to the sub-vertical shear zones hosting the gold deposits at Bevcon and Buffadison, located on the northern contact of the Bevcon Batholith.
New Louvre	Early	East-west elongate intrusion located west of Bevcon and southeast of Bonnefond. Past drilling identified a series of gold-bearing quartz-tourmaline shear-hosted veins.
<b>Bruell Property</b>		
Bruell SW	Early	Historical mineral occurrences and exploration shafts that were following gold-bearing near-surface quartz veins. Sparton Resources in recent drilling intersected significant mineralization associated with altered shear zones around an isolated intrusion south of the Tiblemont Batholith.

Mineral Occurrence or Target	Exploration Stage	Description
Bruell Center	Targeting	Till and soil sample programs identified anomalies in the center of the property which have not been drill-tested.
<b>Uniacke / Perestroika / Perestroika West Properties</b>		
Heva-Cadillac	Early	Gold mineralization was identified by trenching and drilling along a significant northwest trending regional deformation zone (Uniacke). Several high-grade gold results were returned in reconnaissance drilling

## 24.26 Risks and Opportunities

Risks and opportunities were assessed with as part of a cross-functional risk workshop between Eldorado and Lamaque.

### 24.26.1 Risks

Identified risks, mitigation efforts and residual risks are summarized in Table 24-18. The initial and residual risks are assessed based on a combined consequence and likelihood score.

**Table 24-18: Risk Register**

	Category	Description	Initial Risk	Future Controls	Residual Risk
R1	Geology	Lower than expected conversion to Mineral Reserves at Ormaque and Triangle	High	Further exploration drilling	Low
R2	Haulage	Diesel truck haulage to deeper into the mines cannot be sufficiently ventilated and will slow production	Medium	Ensure LOM ventilation model is followed, BEV equipment assessment, consider materials handling alternatives	Low
R3	Mining	Ormaque production does not meet forecast due to drift and fill mining method which is new to site	Medium	Train miners and bring in experts with drift and fill experience	Low
R4	Water Management	Increased water is found in Ormaque that exceeds site water handling capacities	Low	Ensure hydrology is modelled properly and the site water balance is accurate	Low
R5	Water Management	Lamaque tailings facility crown pillar above Ormaque and Sigma-Triangle decline fails resulting in water inflow	Medium	Pillar design, Ormaque geotechnical criteria, diamond drillhole grouting, review of historic drilling and excavations. Geotechnical investigations and monitoring of the crown pill and tailings facility	Medium
R6	Water Management	Lamaque tailings facility crown pillar above Ormaque and Sigma-Triangle decline fails result in tailings inflow	Medium	Pillar design, Ormaque geotechnical criteria, diamond drillhole grouting, review of historic drilling and excavations. Geotechnical investigations and monitoring of the crown pill and tailings facility	Medium
R7	Infrastructure	The paste backfill plant location creates high pipe pressures and line losses	High	Ensure paste recipe is suitable for long pumping distances, install protection system and rupture	Medium

	Category	Description	Initial Risk	Future Controls	Residual Risk
				valves in specific areas. Alternative surface tailings disposal	
R8	Geotechnical	Required paste backfill strengths not achieved	High	Ensure proper testwork and adequate design is carried out	Medium
R9	Ventilation	Blast clearing time is too long.	High	Modify ventilation infrastructure plan	Low
R10	Mining	Low-profile mining equipment is new to site	Low	Training for operators and manufacturer support	Low
R11	Mining	Paste backfill is a new method for Lamaque which may lengthen commissioning time	Medium	Training, systems created for QA/QC, outside consultants during start-up, staged integration, vendor training and site visits	Low
R12	Ventilation	Higher heat at depth	Low	Studies for geothermal gradient, ventilation requirements, BEV assessment	Low
R13	Processing	Ore has lower processing recovery than forecasted	High	Additional sampling and testing to verify recovery, adjustments to mine plans	Low
R14	Processing	Ore hardness change in lower Triangle and Ormaque limit throughput	High	Additional sampling and testing to verify hardness, adjustments to mine plans	Low
R15	Mining	Seismicity	Low	Seismic monitors, ground control plan updates	Low
R16	Geotechnical	Unexpected ground conditions in deposits	High	Ensure adequate drilling and sampling, ground control plan, QA/QC	Low
R17	Environment	Tailings chemistry and ARD generation	Low	Water treatment	Low
R18	Environment	Forest Fires	Medium	Site maintenance to keep combustibles clear from infrastructure, communications with provincial authorities	Medium

### 24.26.2 Opportunities

Opportunities are summarized in Table 24-19, with assessments based on a combined consequence and probability score.

**Table 24-19: Opportunity Register**

	Category	Description	Outcome	Opportunity Level
O1	Geology	Triangle Mineral Resources continue at depth	Additional mine life and ounce production	High
O2	Geology	Ormaque Mineral Resources continues at depth and on strike	Additional mine life and ounce production	High

	Category	Description	Outcome	Opportunity Level
O3	Geology	Discovery of new economic Mineral Resources within Project area or on adjacent properties within trucking distance of Sigma mill	Additional mine life and ounce production	High
O4	Mining	BEV for lower head loads (LHD's)	Reduces ventilation requirement, carbon footprint, social license. BEV trucks are in use and under evaluation.	High
O5	Mining	Automation for increased productivity during shift change	Increased overall productivity	Medium
O6	Mining	Longhole blast optimization study to lower dilution	Higher head grade	Medium
O7	Permitting	Sharing infrastructure between Sigma and Triangle	Lower capital expenditures, plan has been in implementation during Ormaque development and bulk sampling	Medium

---

## 25 Interpretation and Conclusions

### 25.1 Overview

The Lamaque Complex has had a solid history of operational performance since mining in the upper Triangle mine starting with bulk sampling in 2017, progressing to pre-production in late 2018, and commercial production commencing in 2019. The Triangle mine has achieved and surpassed many metrics described in the previous technical reports (2018 and 2021). Production tonnages and gold produced have matched and now exceed the plans outlined in the 2021 report. The Triangle mine is expected to continue to perform as well in the future as it has during the past six years of operations.

The geology of the Triangle deposit is well understood. Diamond drill holes continue to be the principal source of geologic and grade data for the Lamaque Project. The data is well managed and controlled by a robust QA/QC program and database management system. These systems demonstrate that the Lamaque Complex data are sufficiently accurate and precise for resource estimation.

The results of this Technical Report demonstrate that the Project warrants continued development due to its positive and robust economics. Additionally, the Triangle and Ormaque deposits show additional opportunities with further definition of the Inferred Mineral Resources lower in the deposits and represent additional accretive value warranting their further study. To date, the qualified persons are not aware of any fatal flaws on the Project, and the results are considered sufficiently reliable to guide Eldorado management in a decision to further advance the Project. Except for those outlined in this report in Section 24.26.1, the report authors are unaware of any unusual or significant risks or uncertainties that would affect Project reliability or confidence based on the data and information made available.

The report authors have concluded that the work completed in the PFS level assessment of the Triangle deposit, Ormaque deposit, and Parallel deposit Mineral Reserves indicate that the exploration information, Mineral Reserves, and Project economics are sufficiently defined to indicate that the Project and continued operations are technically and economically viable.

The report authors have concluded that the work completed in the PEA level assessment of additional Inferred Mineral Resources from the Triangle and Ormaque deposits, indicate that the exploration information, Inferred Mineral Resource estimations, and Project economics are sufficiently defined to indicate that the extension is potentially technically and economically viable and warrants continued study.

The PEA described in Section 1 should be differentiated from the economic analysis for the Mineral Reserves. The PEA only demonstrates the potential viability of Mineral Resources and is not as comprehensive as the economic analysis for the Mineral Reserves. The level of detail, precision, and confidence in outcomes between the economic analysis for the PFS and the PEA is significantly different.

The PEA is preliminary in nature and is based on numerous assumptions and the incorporation of the Inferred Mineral Resources. Inferred Mineral Resources are considered too speculative geologically to have economic considerations applied to them that would enable them to be categorized as Mineral Reserves except as allowed for by NI 43-101 in PEA studies. There is no guarantee that Inferred Mineral Resources can be converted to Indicated or Measured Mineral Resources and, as such, there is no guarantee that the economics described herein will be achieved. Inferred Mineral Resources that are not Mineral Reserves do not have demonstrated economic viability.

For these reasons, the recommended path forward is to continue exploration and delineation drilling focusing on resource conversion and expansion and to continue advanced studies around the investments required to further develop Triangle and Ormaque.

## 25.2 Mineral Resources and Mineral Reserves

The Mineral Resource and Mineral Reserve estimates are consistent with the CIM definitions referred to in NI 43-101. It is the opinion of the qualified persons that the information and analysis provided in this report is considered sufficient for reporting mineral resources and mineral reserves.

A test of reasonableness for the expectation of economic extraction was made on the Project Mineral Resources by developing underground mine designs based on optimal operational parameters and gold price assumptions. An underground mine design was chosen to constrain mineral resources likely to be mined by underground mining methods. Eligible model blocks within this shell were evaluated at a resource cut-off grade of 3.0 g/t Au.

The Mineral Resource model was used as input for the Mineral Reserve estimate. The modelling methods, grade models, resource classification, and density model were reviewed and found appropriate for the mineral reserve estimation.

Information and data contained in or used in the preparation of the mineral resource update were obtained from historic data from Integra Gold, verified, and supplemented by information from several surface diamond drill campaigns undertaken by Integra Gold and subsequently Eldorado. The Mineral Resource is consistent with the CIM definitions referred to in NI 43-101. The opinion of the qualified persons is that the information and analysis provided in this Technical Report is considered sufficient for reporting Mineral Resources.

Results of drilling indicate the Triangle ore body and the Ormaque ore body are both open at depth. Recent conversion of Inferred Mineral Resources to Measured and Indicated Mineral Resources level in the upper Triangle zones, and conversion of Inferred Mineral Resources to Measured and Indicated Mineral Resources level for the Ormaque deposit, allows for the reasonable possibility of converting lower zones of similar magnitude. Eldorado considers this an opportunity to the Project and further exploration at depth should be completed.

The Mineral Reserve estimates used industry-accepted methods and were classified as Proven and Probable Mineral Reserves using logic consistent with the CIM definitions referred to in NI 43-101. The cut-off grade was calculated from first principles and honors current and projected costs and mining factors. The current Mineral Reserves define almost eight years of mine life, which is at least two more than the life estimated in the 2021 technical report considering higher throughputs.

## 25.3 Mining Methods

The existing underground mine supports the extraction of approximately 2,600 tpd on average. Mining is conducted using a conventional fleet and mining methods, and ventilation, dewatering systems, and electrical infrastructure will be expanded as necessary with mine development.

## 25.4 Metallurgy

Historical test work data and production data was reviewed and provides a high degree of confidence in the process designs and the stated recoveries. Testwork has continued recently with samples from lower Triangle (Zones C6 to C10) and Ormaque. The Ormaque bulk sample was recently processed with results exceeding expectations on both mill throughput and recovery.

## 25.5 Processing and Paste Backfill

This technical study assumes the Sigma mill will maintain capacity of up to 960,000 tpa, with the mill processing 943 kt in 2024 and exceeding previous guidance. The mill is currently operating a

conventional process including crushing, grinding, gravity concentration, leaching, carbon-in-pulp, elution, carbon regeneration, and refinery areas. Minor debottlenecking modifications are planned.

A new paste backfill plant is planned to dewater the Sigma mill tailings and produce a paste suitable for backfilling applications via thickening, pressure filtration, and mixing to produce cemented backfill.

Additional testwork and design work is ongoing to support Project advancement.

## 25.6 Tailings Management Facility

Long-term tailings management plans are sufficient to support the study. The planned expansion of the Sigma TSF will have sufficient capacity to hold the existing Mineral Reserves. With the addition of paste backfill to the operation, the Sigma TSF has capacity for proposed production plans until 2032 with potential for further optimization. Additional capacity will be required to support long term plans by 2029 if conversion of Inferred Mineral Resources is successful. Numerous options have been identified for long term tailings placement and engineering studies are ongoing to assess the technical and economic feasibility of deposition at nearby brownfield sites.

## 25.7 Environmental and Permitting

Under federal and provincial regulations, the Lamaque Project, operated by EGQ and 100% owned by Eldorado, has been fully permitted by all governmental agencies to commercially operate since March 31, 2019.

The Triangle mining zone is permitted under Certificate of Authorizations (CoA) 7610-08-01-70182-29 for mining operations of up to 2,650 tpd within the Triangle deposit. The Sigma mining zone is permitted under CoA 7610-08-01-70095-31, for mining operations of 2,500 tpd from the Parallel and Ormaque deposits to a depth of 366 m. An amendment to the CoA will be required to mine below the 366 m level. The Sigma mill is permitted under CoA 7610-08-01-70095-28 for ore treatment of up to 5,000 tpd.

The operation is fully in accordance with the current EQA legislation in Québec.

## 25.8 Infrastructure

The new surface infrastructure required to support the existing operation at 2,600 tpd and reserve life of mine plans is the addition of a paste plant and reticulation system; expansion of the Sigma TSF; addition of a North Basin for contact water storage; and construction of a new waste rock facility to support development of Ormaque and Parallel.

If Inferred Mineral Resources are converted to reserves, additional tailings capacity and support infrastructure will be required for the Project.

Costs for budgeted and proposed infrastructure is included in the relevant capital cost models.

## 25.9 Capital and Operating Costs, and Financial Modelling

The accuracy of the capital and operating cost estimates is consistent with the standards outlined by the AACE. The economic model has been built from first principles and includes all relevant data and the qualified persons have a high level of confidence in the stated economic performance of the Project.

Eldorado's forecasts of costs are based on a set of assumptions current as of the date of completion of this Technical Report. The realized economic performance achieved on the Project may be affected by factors outside the control of Eldorado, including but not limited to mineral prices and currency fluctuations.

As with most mining projects, there are risks that could affect the economic viability of the Project. Many of these risks are based on a lack of detailed knowledge and can be managed as more sampling, testing, design, and engineering are conducted at more detailed levels of study. Tables in Section 24.26.1 identify what are currently deemed to be the most significant internal project risks, potential impacts, and possible mitigation approaches that could affect the technical feasibility and economic outcome of the Project.

External risks are, to a certain extent, beyond the control of the Project proponents and are much more difficult to anticipate and mitigate, although, in many instances, some risk reduction can be achieved. External risks include things such as the political situation in the Project region, metal prices, exchange rates, and government legislation. These external risks are generally applicable to all mining projects. Negative variance to these items from the assumptions made in the economic model would reduce the profitability of the mine and the mineral resource estimates.

The largest risk to the Project economics is a decrease in gold price. Project economics have been tested to \$1450/oz Au and the Project economics remain positive. Escalation in costs (operating, sustaining capital, or growth capital) have impacts on Project economics to a lesser extent than gold price. Sensitivities were completed in a range of  $\pm 20\%$  and the Project economics remain positive. A test was completed with a 25% increase to all three costs centers and the Project remains economically viable. Economics were tested with varying process recovery in a range of  $\pm 3\%$  and maintained positive economics. Recovery is a reasonable proxy for mining grades, and a test was completed with a 20% recovery loss and economics remained positive.

There are significant opportunities that could improve the economics and/or timing of the Project. The major opportunities that have been identified at this time are summarized in Section 24.26.2, excluding those typical to all mining projects such as changes in metal prices, exchange rates, etc. Further information and assessments are needed before these opportunities should be included in the Project economics.

---

## 26 Recommendations

With the positive results presented in the Technical Report, the exploration campaign and studies are recommended to be advanced in preparation for the future infrastructure requirements supporting an extended mine life.

Recommendations in this section refer to completing work required to continue with mining operations at Triangle or advancing knowledge of the Ormaque deposit. Future capital spending to support mining in new zones will be contingent on successful conversion of Inferred Mineral Resources to Mineral Reserves and are not included in the recommendations listed.

### 26.1 Geology - Exploration

Exploration programs are ongoing at the Lamaque Complex and are advancing on the following recommendations:

- Continue drilling to test the extension of Triangle at depth, extending and defining known and new shear-hosted veins below the C10 Zone, and assessing the potential of stockwork style mineralization.
- Continue drilling to test the extension of Ormaque laterally and at depth.
- Advance drilling programs at Ormaque and Triangle to increase the drilling density required to convert Inferred Mineral Resources to a higher level of confidence.
- Drill to test potential extensions of the mineralized structures at the Parallel deposit and potential for additional mineralized zones below the current resources.
- Generate and test drill new exploration targets on the property showing potential to host significant mineralization based on the compilation and interpretation of all historical and current data and on our understanding of the regional and local ore controls.

### 26.2 Mining – Planning and Operational

The following studies are recommended to evaluate opportunities in mining operations:

- Continue to analyse operational data from the two operational BEV trucks and advance trade-off studies for further mine fleet electrification.
- Advance trade-off study for material handling in lower Triangle.
- Complete mining methods evaluation for lower Triangle.
- Carry out dewatering network modelling and ventilation modelling for further development and mining at depth.

Further development of the Project is not contingent on the recommended mining studies, the studies are for value addition or normal design progression during the life of mine.

### 26.3 Metallurgy and Processing

The following studies are recommended to advance plans for the process operations:

- Advance the PFS-level study of the paste plant to basic engineering level, including plant design, transfer piping from the Sigma mill, and reticulation systems to the Ormaque and Triangle deposits.
- Continue development of long-term tailings management facilities, including expansions of the Sigma TSF and use of the historic Lamaque TSF.

Development of the Project is not contingent on the process studies for the Mineral Reserves described in the Technical Report, the studies reference normal design progression. If additional Inferred Mineral

Resources are converted to Mineral Reserves the Project is contingent of advancing design and permitting of additional tailings storage capacity at an alternative site.

## 26.4 Permitting and Closure

Discussions with the permitting authorities are ongoing on a continuous basis. The following studies are recommended to prepare for future requirements:

- Continue rehabilitation and restoration plans for both the Triangle Zone and Sigma area with considerations for progressive closure.
- Continue the permitting process for amending the Certificate of Authorization 7610-08-01-70095-31 of the Sigma underground mine to allow for mining below Level 12 (below 453 m depth) in Ormaque.
- Start the permitting process for extending mining lease BM-1048 at Triangle Zone to allow extraction of ore from C10 zone. This zone is in the mining claim if resources are converted to reserves.
- Continue geochemical testing of ore and waste from the Ormaque deposit.
- Complete geochemical and environmental characterizations studies on the Parallel ore deposit.
- Further advance environmental study on the Ormaque site.

## 26.5 Budget

Table 26-1 presents a description of the recommended steps for continued advancement of the operation. The table summarizes each item and the estimated cost, where costs are budgeted and included in capital cost evaluations.

**Table 26-1: Proposed Work Program and Budget**

Section	Item	Cost (\$M)
26.1	Geology and exploration programs (Growth)	28.0
26.2	Mine planning and operational improvement studies	1.4
26.3	Metallurgical and processing improvement studies.	1.9
26.4	Permitting support and closure studies	0.7
	<b>Total</b>	<b>32.0</b>

---

## 27 References

- Ayer, J., Amelin, Y., Corfu, F., Kamo, S., Ketchum, J.F., Kwok, K., and Trowell, N.F., 2002a. Evolution of the Abitibi greenstone belt based on U-Pb geochronology: Autochthonous volcanic construction followed by plutonism, regional deformation and sedimentation: *Precambrian Research*, v. 115, p. 63–95.
- Ayer, J.A., Ketchum, J., and Trowell, N.F., 2002b. New geochronological and neodymium isotopic results from the Abitibi greenstone belt, with emphasis on the timing and the tectonic implications of Neoproterozoic sedimentation and volcanism: *Ontario Geological Survey Open File Report 6100*, p. 5-1–5-16.
- Ayer, J.A., Thurston, P.C., Bateman, R., Dubé, B., Gibson, H.L., Hamilton, M.A., Hathway, B., Hocker, S.M., Houlié, M.G., Hudak, G., Ispolatov, V.O., Lafrance, B., Leshner, C.M., MacDonald, P.J., Péloquin, A.S., Piercey, S.J., Reed, L.E., and Thompson, P.H., 2005. Overview of results from the Greenstone Architecture Project: Discover Abitibi Initiative: *Ontario Geological Survey Open File Report 6154*, 146p.
- Beauregard, A.J., Gaudreault, D. and D'Amours, C. 2011. NI 43 101 Technical Report on the Lamaque property, for Integra Gold Corp. 90 pages.
- Beauregard, A.J., Gaudreault, D. and D'Amours, C. 2014. NI 43 101 Technical Report on the Lamaque property. Technical report prepared by Geologica Groupe-Conseil Inc. for Integra Gold Corp. 101 pages.
- Beauregard, A.J., Gaudreault, D. and D'Amours, C., 2013. NI 43 101 Technical Report on the Lamaque property. Technical report prepared by Geologica Groupe-Conseil Inc. for Integra Gold Corp. 354 pages.
- Benn, K., and Moyen, J.F., 2008, The Late Archean Abitibi-Opatoca terrane, Superior province: A modified oceanic plateau: *Geological Society of America Special Paper*, v. 440, p. 173–197.
- Benn, K., Miles, W., Ghassemi, M. R., Gillet, J., 1994. Crustal structure and kinematic framework of the north-western Pontiac Subprovince, Québec: an integrated structural and geophysical study. *Canadian Journal of Earth Sciences*, Vol. 31, pages 271-281.
- Chen, S., Shi, A., Bureau Veritas Commodities Canada Ltd., Metallurgical and Tailing Testing on Triangle Met Samples C5 to C7 - Lamaque Gold Project, Quebec, Report 1901708, December 21, 2020.
- Chen, S., Shi, A., Bureau Veritas Commodities Canada Ltd., Metallurgical Testing on Samples from Lamaque Deep Triangle Zones and Ormaque Deposit Located in Quebec, Canada, Report 2002710, October 7, 2021.
- Chown, E.H., Daigneault, R., Mueller, W., Mortensen, J.K., 1992. Tectonic evolution of the Northern Volcanic Zone, Abitibi Belt, Québec. *Canadian Journal of Earth Sciences*, volume 29, pages 2211-2225. doi/pdf/10.1139/e92-175
- Colvine, A. C., 1989. An empirical model for the formation of Archean gold deposits: products of final cratonization of the Superior Province, Canada. In: Keays, R. R., Ramsay, R., Groves, D. I., (eds). *The Geology of gold deposits: the perspective in 1988*. *Economic Geology Monograph 6*, pp. 37–53.
- Cowan, E.J. Deposit-scale structural architecture of the Sigma-Lamaque gold deposit, Canada—insights from a newly proposed 3D method for assessing structural controls from drill hole data. *Miner Deposita* 55, 217–240.
- Cox, S.F., 2020, The Dynamics of Permeability Enhancement and Fluid Flow in Overpressured, Fracture-Controlled Hydrothermal Systems. *Reviews in Economic Geology*, v. 21, p. 25-82.
- Daigneault, R., Mueller, W.U., Chown, E.H., 2004. Abitibi greenstone belt plate tectonics: the diachronous history of arc development, accretion and collision. In Eriksson, P.G., Altermann, W., Nelson, D.R., Mueller, W.U., Catuneanu, O. (Eds.). *The Precambrian Earth: Tempos and Events*, Series: *Developments in Precambrian geology*, vol. 12, Elsevier, pages. 88–103.

- Davis, W.J., Lacroix, S., Gariépy, C., and Machado, N., 2000. Geochronology and radiogenic isotope geochemistry of plutonic rocks from the central Abitibi subprovince: Significance to the internal subdivision and plutono-tectonic evolution of the Abitibi belt: *Canadian Journal of Earth Sciences*, v. 37, p. 117–133.
- De Souza, S., Dubé, B., McNicoll, V.J., Dupuis, C., Mercier-Langevin, P., Creaser, R.A., and Kjarsgaard, I.M., 2017. Geology and hydrothermal alteration of the world-class Canadian Malartic gold deposit: Genesis of an Archean stockwork-disseminated gold deposit in the Abitibi greenstone belt, Quebec: *Reviews in Economic Geology*, v. 19, p. 263–291.
- Desrocher, J.-P., and Hubert, C., 1996. Structural evolution and early accretion of the Archean Malartic composite block, southern Abitibi greenstone belt, Quebec, Canada: *Canadian Journal of Earth Sciences*, v. 33, p. 1556-1569.
- Desrochers, J.-P., Hubert, C., and Pilote, P., 1993. Géologie du secteur du lac De Montigny (phase 3), région de Val-d'Or. Ministère de l'Énergie et des Ressources, Québec, 47 pages. MB 93-15.
- Dimroth, E., Imrech, L., Rocheleau, M., Goulet, N., 1982. Evolution of the south-central part of the Archean Abitibi Belt, Quebec. Part I: stratigraphy and paleostratigraphic model. *Canadian Journal of Earth Sciences*, Vol. 19, pages 1729-1758.
- Dimroth, E., Imrech, L., Rocheleau, M., Goulet, N., 1983b. Evolution of the south-central part of the Archean Abitibi Belt, Quebec. Part III: plutonic and metamorphic evolution and geotectonic model. *Canadian Journal of Earth Sciences*, Vol. 20, pages 1374-1388.
- Dimroth, E., Imrech, L., Rocheleau, M., Goulet, N., 1983b. Evolution of the south-central part of the Archean Abitibi Belt, Quebec. Part III: plutonic and metamorphic evolution and geotectonic model. *Canadian Journal of Earth Sciences*, Vol. 20, pages 1374-1388.
- Dimroth, E. - Imrech, L. - Rocheleau, M. - Goulet, N., 1983a. Evolution of the south-central part of the Archean Abitibi Belt, Québec. Part II: Tectonic évolution and geochemical model. *Canadian Journal of Earth Science*; volume 20, pages 1355-1373.
- Dubé, B., and Gosselin, P., 2007. Greenstone-hosted quartz–carbonate vein deposits. In: Goodfellow, W. D. (ed). *Mineral deposits of Canada: a synthesis of major deposit-types, district metallogeny, the evolution of geological provinces, and exploration methods*. Geological Association of Canada, Mineral Deposits Division, Special Publication 5, pp. 49–73.
- Dubé, B., and Mercier-Langevin, P., 2020. Gold Deposits of the Archean Abitibi Greenstone Belt, Canada, SEG Special Publications, no. 23, pp. 669–708.
- Dubé, J., 2018, Caractérisation métallogénique et structurale de la minéralisation aurifère des gisements Triangle et Cheminée No. 4, Val-d'Or, Abitibi, Québec: M.Sc. thesis, Québec, Canada, Université du Québec à Chicoutimi, 259 p.
- Eisenlohr, B. N., Groves, D. I., and Partington, G. A., 1989. Crustal-scale shear zones and their significance to Archean gold mineralization in Western Australia. *Mineralium Deposita*, v. 24(1), pp.1–8.
- Gaboury, D., Carrier, A., Crevier, M., Pelletier, C., and Sketchley, D.A., 2001. Predictive distribution of fault-fill and extensional veins: Example from the Sigma gold mine, Abitibi subprovince, Canada. *Economic Geology*, v. 96, p. 1397-1405.
- Garofalo, P., 2000. Gold precipitation and hydrothermal alteration during fluid flow through the vein network of the mesothermal gold deposit of Sigma (Abitibi belt, Canada): Unpublished Ph.D. thesis, Zurich, Swiss Federal Institute of Technology, 246 pages.

- Girard, F., Roy, L., Turcotte, B., Gaudreault, D., 2017. InnovExplo Inc., NI 43-101 Technical Report on the Spring 2017 Mineral Resource Estimate Update for The Lamaque Project, 481p
- Goldfarb, R.J., Baker, T., Dubé, B., Groves, D.I., Hart, C.J.R., and Gosselin, P., 2005, Distribution, character, and genesis of gold deposits in metamorphic terranes: Economic Geology 100th Anniversary Volume, p. 407–450.
- Goutier, J., and Melançon, M., 2007. Compilation géologique de la Sous-province de l'Abitibi (version préliminaire): Ministère des Ressources naturelles et de la Faune du Québec.
- Goutier, J., Mercier-Langevin, P., McNicoll, V., and Ayer, J., 2010, The Abitibi subprovince: Its evolution and its VMS deposits—an overview [ext. abs.] International Archean Symposium, 5th, Perth, Western Australia, 2010, Abstracts of the Yilgarn-Superior Workshop, p. 37–41.
- Gunning, H.C. and Ambrose, J.W., 1940. Malartic area, Québec. Geological Survey of Canada, Memoir 222. 142 pages.
- Hodgson, C. J., 1993. Mesothermal lode–gold deposits. In: Kirkham, R. V., Sinclair, W. D., Thorpe, R. I., Duke, J. M., (eds). Mineral deposits modelling. Geological Association of Canada, Special Paper 40, pp. 635–678.
- Imreh, L., 1976. Nouvelle lithostratigraphie à l'ouest de Val-d'Or et son incidence géologique. Ministère des Richesses Naturelles, Québec. 73 pages. DP-349.
- Imreh, L., 1984. Sillon de La Motte-Vassan et son avant-pays méridional: Synthèse volcanologique lithostratigraphique et géologique. Ministère de l'Énergie et des Ressources du Québec. 72 pages. MM 82-04.
- Jemielita, R. A., Davis, D. W., Krogh, T. E., and Spooner, E. T. C., 1989. Chronological constraints on the origin of Archean lode gold deposits in the southern Superior Province from U-Pb isotopic analyses of hydrothermal rutile and titanite. Geol. Soc. America Ann. Mtg., Abstracts with Programs, 21 : A351.
- Jemielita, R.A., Davis, D.W., and Krogh, T.E., 1990, U/Pb evidence for Abitibi gold mineralization postdating greenstone magmatism and metamorphism. Nature, v. 346, p. 831–834.
- Jolly, W. T., 1978. Metamorphic history of the Archean Abitibi Belt. In Metamorphism in the Canadian Shield. Geological Survey of Canada, Paper 78-10, pp. 63-78.
- Karvinen, William., 1985, Geology of the Lamaque Mine property. Val-d'Or, Québec. Project IREM P-83-21 7th Rapport, Ministère de l'Énergie et des Ressources du Québec.
- Keogh, C., Simoneau, J., Juras, S., Ph.D., Chabot, F., 2018. Eldorado Gold Corporation. NI 43-101 Technical Report Lamaque Project, 322p.
- Kerrich, R., Goldfarb, R. J., Groves, D. I., Garwin, S., 2000. The geodynamics of the world-class gold deposits: characteristics, space–time distribution and origins. In: Hagemann, S. G., Brown, P. E. (eds). Gold in 2000, Reviews in Economic Geology v. 13, pp. 501–552.
- Kolb J., Hellmann, A., Rogers, A., Sinderin, S., Vennemann, T., Böttcher, M. E., Meyer, M. F., 2004. The role a transcrustal shear zone in orogenic gold mineralization at the Ajjanahalli Mine, Dharwar Craton, South India. Economic Geology, v.99, pp. 743–759.
- Latulippe, M., 1976. Excursion géologique Val-d'Or-Malartic. Ministère des Richesses Naturelles, Québec, 124 pages. DPV-367.
- Lewis, W.J., Harris, G., Mukhopadhyay, D. K., Patrick, G. and Lattanzi, C. R., 2011 Technical review of the Mining Plan/Operations and audit of the Resource and Reserve Estimates for the Lamaque Mine Project. Technical report prepared by MICON International Ltd for Century Mining Corp., 223 pages.

- Ludden, J.N., Hubert, C., and Gariépy, C., 1986. The tectonic evolution of the Abitibi greenstone belt of Canada: *Geological Magazine*, v. 123, pp. 153-166.
- McCuaig, T.C., and Kerrich, R., 1998. P–T–t–deformation–fluid characteristics of lode gold deposits: evidence from alteration systematics. *Ore Geology Reviews*, v. 12:381–453.
- McKinley, S., Siron, C.R., Simoneau, J., Mactar-Dieng, P., LaFrance, N., Baker, T., and Lewis, P., 2021, 3D Structural Modelling Using Oriented Drill Core: A Best-practice Case Study from the Ormaque discovery, Val-d'Or Mining Camp, Québec, SEG 100 Conference: Celebrating a Century of Discovery, Abstract Volume, Whistler.
- Monecke, T., Mercier-Langevin, P., Dubé, B., and Frieman, B.M., 2017, Geology of the Abitibi greenstone belt: *Reviews in Economic Geology*, v. 19, p. 7–49.
- Morin, D., Jébrak M., Beaufort, D., Meunier, A., 1993. Metamorphic evolution of the late Archean Cadillac Tectonic Zone, McWatters, Abitibi belt, Quebec. *Journal Metamorphic Geology*, v.11, pp. 121–135.
- Neumayr, P., Hagemann, S. G., Banks, D. A., Yardley, B. W.D., Couture, J.-F., Landis, G. P., Rye, R., 2007. Fluid chemistry and evolution of hydrothermal fluids in an Archean transcrustal fault zone network: the case of the Cadillac Tectonic Zone, Abitibi greenstone belt Canada. *Canadian Journal of Earth Sciences*, v. 44, pp.745–773.
- Neumayr, P., S.G. Hagemann and J.-F. Couture, 2000, Structural setting, textures and timing of hydrothermal vein systems in the Val-d'Or camp, Abitibi, Canada: Implications for the evolution of transcrustal, second- and third-order fault zones and gold mineralization. *Can. J. of Earth Sci.* 37. pp. 95-114.
- Norman, G.W.H., 1947, Dubuisson, Bourlamaque, Louvicourt: Geological Survey of Canada Paper 47-20, p. 39-60.
- Olivo, G. R., Chang, F. C., Kyser, T. K., 2006. Formation of the Auriferous and Barren North Dipper Veins in the Sigma Mine, Val-d'Or, Canada: Constraints from Structural, Mineralogical, Fluid Inclusion, and Isotopic Data. *Economic Geology*, v. 101, pp. 607-631.
- OURANOS, weather date
- Perrault, Guy, Pierre Trudel and Paul Bedard, 1984, Auriferous Halos Associated with the Gold Deposits at Lamaque mine. Québec. *Econ Geol.* 79. pp. 227-238.
- Phillips, G. N., and Powell, R. 2009. Formation of gold deposits: review and evaluation of the continuum model. *Earth Sciences Reviews*, v. 94, pp.1–21.
- Pilote, P, Mueller, W., Lavoie, S., and Riopel, P, 1999, Géologie des Formations Val-d'Or, Héva et Jacola - nouvelle interprétations du Groupe de Malartic. Ministère des Ressources Naturelles du Québec. 19 pages. DV 99-03.
- Pilote, P, Mueller, W., Scott, C., Lavoie, S., Champagne, C., and Moorhead, J., 1998b, Volcanology of the Val-d'Or Formation of the Malartic Group, Abitibi subprovince: Geochemical and geochronological constraints. Ministry of Natural Resources, Quebec. 48 pages. DV 98-05.
- Pilote, P. - Moorhead, J. - Mueller, W., 1998a. Développement d'un arc volcanique, la région de Val-d'Or, Ceinture de l'Abitibi -Volcanologie physique et évolution métallogénique. Association géologique du Canada - Association minéralogique du Canada, Réunion annuelle, Québec 1998; Guide d'excursion A2, 85 pages.
- Pilote, P., 2015a. Géologie – Val-d'Or. Carte de compilation géoscientifiques, scale: 1: 20,000. Direction générale de Géologie Québec. Ministère des Ressources naturelles du Québec. CG-32C04A-2015-01.
- Pilote, P., 2015b. Géologie – Lac de Montigny. Carte de compilation géoscientifiques, scale: 1: 20,000. Direction générale de Géologie Québec. Ministère des Ressources naturelles du Québec. CG-32C04C-2015-01.
- Pilote, P., Lacoste, P., David, J., Daigneault, R., McNicoll, V., and Moorhead, J., 2015c. La région de Val-d'or – Malartic: volcanologie et évolution métallogénique. In *Stratigraphy, volcanology and metallogenic evolution of Val-*

- d'Or – Malartic (Québec), Kirkland Lake, and Timmins (Ontario) areas, Abitibi Subprovince. Edited by P. Pilote and S. Préfontaine. Ministère de l'énergie et des Ressources naturelles du Québec and Ontario Geological Survey. 147 pages.
- Pilote, P., Moorhead, J., and Mueller, W., 2000, Partie A. Développement d'un arc volcanique, La région de Val-d'Or, ceinture de l'Abitibi: volcanologie physique et évolution métallogénique. Ministère des Ressources Naturelles du Québec. 110 pages. MB 2000-09.
- Pilote, P., Mueller, W., Moorhead, J., Scott, C., and Lavoie, S., 1997, Geology, volcanology and lithogeochemistry of the Val-d'Or and Heva Formations, Val-d'Or district, Abitibi subprovince. Ministry of Natural Resources, Quebec, 47 pages. DV 97-01.
- Poirier, S., Roy, L., D'Amours, C., Gaudreault, D., Bergeron, S., Caron, M., 2014. NI 43 101 Technical Report and Preliminary Economic Assessment for the Lamaque Project (according to National Instrument 43-101 and Form 43-101F1), Bourlamaque Township, Province of Québec, Canada. Technical report prepared by InnovExplo for Integra Gold Corp., 257 pages.
- Poirier, S., Roy, L., D'Amours, C., Gaudreault, D., Bergeron, S., Ilieva, T., Utiger, M., 2015a. Technical Report and Updated Preliminary Economic Assessment for the Lamaque Project (according to National Instrument 43-101 and Form 43-101F1), Bourlamaque Township, Province of Québec, Canada. Technical report prepared by InnovExplo for Integra Gold Corp., 354 pages.
- Poirier, S., Roy, L., D'Amours, C., Gaudreault, D., Bergeron, S., Ilieva, T., Utiger, M., 2015b. Technical Report and Mineral Resource Estimate for the Lamaque Project (according to National Instrument 43-101 and Form 43-101F1), Bourlamaque Township, Province of Québec, Canada. Technical report prepared by InnovExplo for Integra Gold Corp., 362 pages.
- Poulsen, K.H., 2017, The Larder Lake-Cadillac Break and its gold districts: Reviews in Economic Geology, v. 19, p. 133–167.
- Powell, W. D., Carmichael, D. M., and Hodgson, C. J., 1993. Thermobarometry in a subgreenschist to greenschist transition in metabasite of the Abitibi greenstone belt, Superior Province, Canada. *Journal of Metamorphic Geology*, Vol. 11, pages 165-178.
- Risto, R. W., Beaugard, A. J., and Gaudreault, D., 2004, Technical report on the Lamaque property, Val-d'Or, Québec for Kalahari Resources Inc. by Watts, Griffis and McQuat Limited. 138 pages.
- Rivoirard et al., 2012, "A Top-Cut Model for Deposits with Heavy-Tailed Grade Distribution."; *Math Geosci* (2013) 45:967-982.
- Robert, F., 1983. Etude du mode de mise en place des veines aurifères de la mine Sigma, Val-d'Or, Québec: Unpublished Ph.D. thesis, Ecole Polytechnique, University of Montreal, 295 pages.
- Robert, F., 1989. Internal structures of the Cadillac Tectonic Zone, southeast of Val-d'Or, Abitibi greenstone belt, Québec. *Canadian Journal of Earth Sciences*, v. 26, p. 2661-2675.
- Robert, F., 1989. Internal structures of the Cadillac Tectonic Zone, southeast of Val-d'Or, Abitibi greenstone belt, Québec. *Canadian Journal of Earth Sciences*, v. 26, p. 2661-2675.
- Robert, F., and Brown, A.C., 1986a. Archean gold-bearing quartz veins at the Sigma mine, Abitibi greenstone belt, Québec. Part I. Geological relations and formation of vein system: *Economic Geology*, v. 81, p. 578-592.
- Robert, F., and Brown, A.C., 1986b. Archean gold-bearing quartz veins at the Sigma mine, Abitibi greenstone belt, Québec. Part II. Vein paragenesis and hydrothermal alteration: *ECONOMIC GEOLOGY*, v. 81, p. 593-616.

- Robert, F., and Kelly, W.C., 1987. Ore-Forming Fluids in Archean Gold-Bearing Quartz Veins at the Sigma Mine, Abitibi Greenstone Belt, Quebec, Canada, *Economic Geology*, Vol. 82, 1987, pp. 1464-1482
- Robert, F., and Kelly, W.C., 1987. Ore-Forming Fluids in Archean Gold-Bearing Quartz Veins at the Sigma Mine, Abitibi Greenstone Belt, Quebec, Canada, *Economic Geology*, Vol. 82, 1987, pp. 1464-1482
- Robert, F., and Kelly, W.C., 1987. Ore-Forming Fluids in Archean Gold-Bearing Quartz Veins at the Sigma Mine, Abitibi Greenstone Belt, Quebec, Canada, *Economic Geology*, Vol. 82, 1987, pp. 1464-1482
- Sauvé, P, Imreh, L., and Trudel, P., 1993. Description des gîtes d'or de la région de Val-d'Or, Ministère de l'Énergie et des Ressources du Québec. MM-91-03. 178 p.
- Scott, C R., Mueller, W. U., and Pilote, P., 2002, Physical volcanology. stratigraphy. and lithogeochemistry of an Archean volcanic arc: evolution from plume-related volcanism to arc rifting of SE Abitibi Greenstone Belt. Val-d'Or, Canada. *Precambrian Research* 115. pp. 223-260.
- Scott, C.R., 2005. Physical volcanology, stratigraphy, and lithogeochemistry of an Archean volcanic arc: evolution from plume-related volcanism to arc rifting within the SE Abitibi Greenstone Belt, Val-d'Or, Quebec, Canada. Université du Québec à Chicoutimi; thèse de doctorat, 473 pages.
- Sibson, R.H., Robert, F., and Poulsen, K.H., 1988, High-angle reverse faults, fluid-pressure cycling, and mesothermal gold-quartz deposits: *Geology*, v. 16, p. 551–555.
- Simard, M., Gaboury, D., Daigneault, R., and Mercier-Langevin, P., 2013. Multistage gold mineralization at the Lapa mine, Abitibi Subprovince: insights into auriferous hydrothermal and metasomatic processes in the Cadillac-Larder Lake Fault Zone. *Mineralium Deposita*, Volume 48, Issue 7, pp. 883-905.
- Simoneau, J., Lind, P., Uludag, E., McKinley, S., Thelland, J., Bouanani, M., Tran, V., Sutherland, D., 2022. Eldorado Gold Corporation, NI 43-101 Technical Report Lamaque Project, 340p.
- Statistics Canada weather data
- Thurston, P.C., Ayer, J.A., Goutier, J., and Hamilton, M.A., 2008, Depositional gaps in the Abitibi greenstone belt stratigraphy: A key to exploration for syngenetic mineralization. *Economic Geology*, v. 103, p. 1097–1134.
- Tomkins A. G., and Mavrogenes J. A., 2001. Redistribution of gold within arsenopyrite and löllingite during pro- and retrograde metamorphism: application to timing of mineralization. *Economic Geology* 96, 525–534.
- Tomkins A. G., Pattinson D. R. M., Zaleski, E., 2004 The Hemlo gold deposit, Ontario: an example of melting and mobilization of a precious metal–sulfosalt assemblage during amphibolite facies metamorphism and deformation. *Economic Geology* 99,1063–1084.
- Wong, L., Davis, D.W, Krogh, T.E., and Robert, E, 1991. U-Pb zircon and rutile chronology of Archean greenstone formation and gold mineralization in the Val-d'Or region, Quebec. *Earth and Planetary Science Letters*, v. 104, p. 325-336

---

## 28 Date and Signature Page

The effective date of this report entitled “Technical Report, Lamaque Complex, Québec, Canada” is December 31, 2024.

It has been prepared for Eldorado Gold Corporation by David Sutherland, P.Eng., Mike Tsafaras, P.Eng, Peter Lind, P.Eng., Ertan Uludag, P.Geo., and Sean McKinley P.Geo., each of whom are qualified persons as defined by NI 43-101.

Signed the 27<sup>th</sup> day of January, 2025.

**“Signed and Sealed”**

*David Sutherland*

\_\_\_\_\_  
**David Sutherland, P. Eng.**

**“Signed and Sealed”**

*Jacques Simoneau*

\_\_\_\_\_  
**Jacques Simoneau, P. Geo.**

**“Signed and Sealed”**

*Peter Lind*

\_\_\_\_\_  
**Peter Lind, Eng., P.Eng.**

**“Signed and Sealed”**

*Jessy Thelland*

\_\_\_\_\_  
**Jessy Thelland, P. Geo.**

**“Signed and Sealed”**

*Philippe Groleau*

\_\_\_\_\_  
**Philippe Groleau, Eng.**

**“Signed and Sealed”**

*Mehdi Bouanani*

\_\_\_\_\_  
**Mehdi Bouanani, Eng.**

**“Signed and Sealed”**

*Vu Tran*

\_\_\_\_\_  
**Vu Tran, Eng.**

CERTIFICATE OF QUALIFIED PERSON

David Sutherland, P. Eng.  
1188 Bentall 5, 550 Burrard St.  
Vancouver, BC  
Tel: (604) 601-6658  
Fax: (604) 687-4026  
Email: [david.sutherland@eldoradogold.com](mailto:david.sutherland@eldoradogold.com)

I, David Sutherland, am a Professional Engineer, employed Senior Manager, Projects and Technical Studies, of Eldorado Gold Corporation located at 1188 Bentall 5, 550 Burrard St., Vancouver in the Province of British Columbia.

This certificate applies to the technical report entitled *Lamaque Complex Technical Report*, with an effective date of December 31, 2024.

I am a member of the Engineers & Geoscientists of British Columbia. I graduated from Lakehead University with a Bachelor of Science (Physics) in 2003 and a Bachelor of Engineering (Mechanical) in 2005.

I have practiced my profession continuously since 2005. Since receiving my professional designation, I have worked exclusively on the design of mineral processing plants, assisted on numerous technical studies in accordance with National Instrument - Standards of Disclosure for Mineral Projects ("National Instrument 43-101") and have directed engineering and procurement on three mineral processing projects through construction. For 30 years I have been working in heavy industry including operations, maintenance and construction. During this time, I have led the design and construction of major greenfield and brownfield construction projects in Canada, Turkey, and Greece.

As a result of my experience and qualifications, I am a Qualified Person as defined in National Instrument - 43-101.

I have visited the Lamaque Complex on numerous occasions with my most recent visit occurring on May 28 to 30, 2024 (3 days).

I am responsible for items 1, 2, 3, 5, 12.2.1, 19, 20, 24.1, 24.2, 24.3, 24.5, 24.12, 24.19, 24.20, 24.24, 24.25, 24.26, 25, and 26 in the technical report.

I am not independent of Eldorado Gold Corporation in accordance with the application of Section 1.5 of National Instrument 43-101.

I have read National Instrument 43-101 and Form 43-101F1 and the items for which I am responsible in the technical report entitled *Lamaque Complex Technical Report* with an effective date of December 31, 2024, has been prepared in compliance with same.

As of the effective date of the technical report, to the best of my knowledge, information and belief, the items of the technical report that I was responsible for contain all scientific and technical information that is required to be disclosed to make the technical report not misleading.

Dated at Vancouver, British Columbia, this 27<sup>th</sup> day of January, 2025.

***"Signed and Sealed"***

*David Sutherland*

---

David Sutherland, P. Eng.

CERTIFICATE OF QUALIFIED PERSON

Jacques Simoneau, P. Geo.

300 3<sup>e</sup> Avenue Val-d'Or, QC

Tel: (819) 825-2541

Email: [jacques.simoneau@eldoradogold.com](mailto:jacques.simoneau@eldoradogold.com)

I, Jacques Simoneau, am a Professional Geologist, employed as Exploration Manager, Eastern Canada with Eldorado Gold (Québec) Inc. (a wholly owned subsidiary of Eldorado Gold Corporation) located at 300 3<sup>e</sup> Avenue, Val-d'Or in the Province of Québec.

This certificate applies to the technical report entitled Lamaque Complex Technical Report, with an effective date of December 31, 2024.

I am a member in good standing of the Ordre des Géologues du Québec (OGQ No. 737). I am a graduate in Geology from the Université de Montréal (1988). I have more than 25 years relevant experience in exploration geology, most of it related to gold exploration on projects similar to the Triangle Gold Deposit.

I have read the definition of “qualified person” (“QP”) set out in National Instrument 43-101 - Standards of Disclosure for Mineral Projects/Regulation 43-101 (“National Instrument 43-101”) and certify that by reason of my education, affiliation with a professional association (as defined in NI 43-101) and past relevant work experience, I am a QP for the purpose of NI 43- 101.

I have been working full time on the Lamaque Complex, including the Triangle Deposit, since February 2015, first with Integra Gold Corporation and since July 2017 with Eldorado Gold (Québec) Inc. My last site personal inspection was completed on December 12, 2024 (1 day).

I am responsible for items 4, 6, 7, 8, 9, 10, 11, 12.2.2, 23, 24.4, 24.6 through 24.11, and 24.23 in the technical report.

I am not independent of Eldorado Gold Corporation in accordance with the application of Section 1.5 of National Instrument 43-101.

I have read National Instrument 43-101 and Form 43-101F1 and the items for which I am responsible in the report entitled Lamaque Complex Technical Report with an effective date of December 31 , 2024, have been prepared in compliance with same.

As of the effective date of the technical report, to the best of my knowledge, information and belief, the items of the technical report that I was responsible for contain all scientific and technical information that is required to be disclosed to make the technical report not misleading.

Dated at Val-d'Or, Québec, this 27<sup>th</sup> day of January, 2025.

***“Signed and Sealed”***

*Jacques Simoneau*

---

*Jacques Simoneau, P. Geo.*

## CERTIFICATE OF QUALIFIED PERSON

Peter Lind, Eng., P.Eng.  
1188 Bentall 5, 550 Burrard St.  
Vancouver, BC  
Tel: (604) 601-6658  
Fax: (604) 687-4026  
Email: [peter.lind@eldoradogold.com](mailto:peter.lind@eldoradogold.com)

I, Peter Lind, am a Professional Engineer, employed as Vice President, Technical Services of Eldorado Gold Corporation and reside at 999 West 38<sup>th</sup> Ave, Vancouver in the Province of British Columbia.

This certificate applies to the technical report entitled *Lamaque Complex Technical Report*, with an effective date of December 31, 2024.

I am a member of the Ordre des ingénieurs du Québec and Engineers & Geoscientists British Columbia. I graduated from Laurentian University with a Bachelor of Engineering in Extractive Metallurgy in 2002, a Bachelor of Commerce from the University of Windsor in 2006, and an MBA from Simon Fraser University in 2017.

I have practiced my profession continuously since 2002 and have been involved with mineral processing and metallurgical operations and development projects in Canada, the United States, Mexico, Chile, Peru, Argentina, Tanzania, Greece, and Türkiye.

As a result of my experience and qualifications, I am a Qualified Person as defined in National Instrument 43-101 - Standards of Disclosure for Mineral Projects (“National Instrument 43-101”).

I have visited the Lamaque Complex on numerous occasions with my most recent visit occurring on January 16, 2025 (1 day).

I am responsible for items 12.2.3, 13, 17, 24.13, and 24.17 in the technical report.

I am not independent of Eldorado Gold Corporation in accordance with the application of Section 1.5 of National Instrument 43-101.

I have read National Instrument 43-101 and Form 43-101F1 and the items for which I am responsible in the technical report entitled *Lamaque Complex Technical Report* with an effective date of December 31, 2024, has been prepared in compliance with same.

As of the effective date of the technical report, to the best of my knowledge, information and belief, the items of the technical report that I was responsible for contain all scientific and technical information that is required to be disclosed to make the technical report not misleading.

Dated at Vancouver, British Columbia, this 27<sup>th</sup> day of January, 2025.

**“Signed and Sealed”**

*Peter Lind*

---

Peter Lind, P.Eng.

## CERTIFICATE OF QUALIFIED PERSON

Jessy Thelland, P.Geo.  
1000, voie de Service Goldex-Manitou  
Val-d'Or, Qc  
Tel: 819-874-3100 # 1201  
Cell: (819) 860-7419  
Email: [jessy.thelland@eldoradogold.com](mailto:jessy.thelland@eldoradogold.com)

I, Jessy Thelland, am a Professional geologist, employed as Director of Technical Services, of Eldorado Gold Québec inc. (wholly-owned subsidiary of Eldorado Gold Corporation) located at 1000, voie de Service Goldex-Manitou, Val-d'Or in the Province of Québec.

This certificate applies to the technical report entitled *Lamaque Complex Technical Report*, with an effective date of December 31, 2024.

I am a member of the Ordre des Géologues du Québec (permit 00758). I graduated from the Université du Québec à Chicoutimi with a Bachelor of Earth Sciences in 2002.

I have practiced my profession continuously since 2002 and have acquired my mining geology and exploration expertise across various positions with Campbell Resources, Cambior Inc, Richmond Mines Inc, Integra Gold Corporation and Eldorado Gold Québec.

As a result of my experience and qualifications, I am a Qualified Person as defined in National Instrument 43-101 - Standards of Disclosure for Mineral Projects/Regulation 43-101 ("National Instrument 43-101").

I am based at the Lamaque Complex since August 2016, where I work on site.

I am responsible for items 12.1, 12.2.4, 14, 15, 16, 21, 22, 24.14, 24.15 and 24.16 in the technical report.

I am not independent of Eldorado Gold Corporation in accordance with the application of Section 1.5 of National Instrument 43-101.

I have read National Instrument 43-101 and Form 43-101F1 and the items for which I am responsible in the technical report entitled *Lamaque Complex Technical Report* with an effective date of December 31, 2024, has been prepared in compliance with same.

As of the effective date of the technical report, to the best of my knowledge, information and belief, the items of the technical report that I was responsible for contain all scientific and technical information that is required to be disclosed to make the technical report not misleading.

Dated at Val-d'Or, Québec, this 27<sup>th</sup> day of January, 2025.

**"Signed and Sealed"**

Jessy Thelland

\_\_\_\_\_  
Jessy Thelland, P.Geo.

## CERTIFICATE OF QUALIFIED PERSON

Philippe Groleau, Eng.  
300, 3<sup>e</sup> avenue Est  
Val d'Or, QC  
Tel: (819) 651-1099

Email: [Philippe.Groleau@eldoradogold.com](mailto:Philippe.Groleau@eldoradogold.com)

I, Philippe Groleau, am a Professional Engineer, employed as Senior Strategic Planner, of Eldorado Gold (Québec) Inc., (a wholly owned subsidiary of Eldorado Gold Corporation) located at 300, 3e avenue Est, Val d'Or in the Province of Québec.

This certificate applies to the technical report entitled *Lamaque Complex Technical Report*, with an effective date of December 31, 2024.

I am a member of the Order of Engineer of Québec. I graduated from Université Laval in Bachelor of Mining Engineering in 2012 and MBA from Université du Québec en Abitibi- Témiscamingue (UQAT) in 2020.

I have practiced my profession continuously since 2012 and have worked for Osisko Mining and Agnico-Eagle, IAMGOLD, Eldorado Gold Corp and Sayona Mining, in open pit and underground mines for gold and lithium minerals.

I have experience in underground narrow vein mining for gold deposit working previously at the Lamaque mine, Westwood mine and Windfall project, as well as Barkerville Gold Mines. I contributed in the past to multiple technical studies varying from PEA to DFS level.

As a result of my experience and qualifications, I am a Qualified Person as defined in National Instrument 43-101 - Standards of Disclosure for Mineral Projects/Regulation 43-101 ("National Instrument 43-101").

I currently work at the Ormaque Project daily and supervise the bulk sample campaign, visiting the underground workings on a weekly basis. My last site personal inspection was completed on January 20<sup>th</sup>, 2025 (1 day).

I was responsible for coordinating the preparation of the technical report. I am responsible for items 12.2.5, 15.3, 16, 18.6, 21, 24.15 and 24.16 specific to the Ormaque deposit in the technical report.

I am not independent of Eldorado Gold Corporation in accordance with the application of Section 1.5 of National Instrument 43-101.

I have read National Instrument 43-101 and Form 43-101FI and the items for which I am responsible in this report entitled *Lamaque Complex Technical Report* with an effective date of December 31, 2024, has been prepared in compliance with same.

As of the effective date of the technical report, to the best of my knowledge, information and belief, the items of the technical report that I was responsible for contain all scientific and technical information that is required to be disclosed to make the technical report not misleading

Dated at Montreal, Québec, this 27<sup>th</sup> day of January, 2025.

***"Signed and Sealed"***

Philippe Groleau

\_\_\_\_\_  
Philippe Groleau, Eng.,

## CERTIFICATE OF QUALIFIED PERSON

Mehdi Bouanani, Eng.

300 3<sup>e</sup> avenue Est.

Val-d'Or, QC

Tel: (819) 874-3100

Fax: (819) 874-0051

Email: [Mehdi.Bouanani@eldoradogold.com](mailto:Mehdi.Bouanani@eldoradogold.com)

I, Mehdi Bouanani, am a Professional Engineer, employed as Senior Director, Construction Projects, of Eldorado Gold (Québec) Inc. (a wholly owned subsidiary of Eldorado Gold Corporation) located at 300 3<sup>e</sup> avenue Est, Val-d'Or in the Province of Québec.

This certificate applies to the technical report entitled *Lamaque Complex Technical Report*, with an effective date of December 31, 2024.

I am a member of the Order of Engineers of Québec. I graduated from Université du Québec en Abitibi-Témiscamingue (UQAT) Bachelor of Engineering (Electromecanical mining) in 2007.

I have practiced my profession continuously since 2007 and have worked on engineering, procurement and construction projects in Canada, South America, and Africa for various mines. I have worked on numerous feasibility studies for gold, copper, extraction projects.

As a result of my experience and qualifications, I am a Qualified Person as defined in National Instrument 43-101 - Standards of Disclosure for Mineral Projects/Regulation 43-101 ("National Instrument 43-101").

I have visited the Lamaque Complex on numerous occasions with my most recent visit occurring on December 18, 2024 (1 day).

I am responsible for items 12.2.6, and 18.1 through 18.5, 18.7 through 18.9 and 24.18 in the technical report.

I am not independent of Eldorado Gold Corporation in accordance with the application of Section 1.5 of National Instrument 43-101.

I have read National Instrument 43-101 and Form 43-101F1 and the items for which I am responsible in this report entitled *Lamaque Complex Technical Report* with an effective date of December 31, 2024, have been prepared in compliance with same.

As of the effective date of the technical report, to the best of my knowledge, information and belief, the items of the technical report that I was responsible for contain all scientific and technical information that is required to be disclosed to make the technical report not misleading

Dated at Montreal, Québec, this 27<sup>th</sup> day of January 2025.

***"Signed and sealed"***

Mehdi Bouanani

---

Mehdi Bouanani, Eng.

CERTIFICATE OF QUALIFIED PERSON

Vu Tran, Ing.  
300, 3<sup>e</sup> avenue Est  
Val d'Or, QC  
Tel: (819) 856-3359  
Email: [vu.tran@eldoradogold.com](mailto:vu.tran@eldoradogold.com)

I, Vu Tran, am a Professional Engineer, employed as Senior Geotechnical Engineer, of Eldorado Gold (Québec) Inc. (a wholly owned subsidiary of Eldorado Gold Corporation) located at 300, 3e avenue Est, Val d'Or in the Province of Québec.

This certificate applies to the technical report entitled *Lamaque Complex Technical Report*, with an effective date of December 31, 2024.

I am a member of the Order of Engineer of Quebec. I graduated from the Ecole Polytechnique with a Bachelor of Civil Engineering in 2007.

I have practiced my profession continuously since 2007 and have worked on engineering and construction projects in Canada for various mines. I have worked on numerous feasibility studies for gold, nickel and iron extraction projects.

As a result of my experience and qualifications, I am a Qualified Person as defined in National Instrument 43-101 - Standards of Disclosure for Mineral Projects ("National Instrument 43-101").

I have visited the Lamaque Complex on numerous occasions with my most recent visit occurring on December 3 to December 5, 2024 (3 days).

I am responsible for items 12.2.7, 18.10, 18.11, 18.12, and 24.18.1 in the technical report.

I am not independent of Eldorado Gold Corporation in accordance with the application of Section 1.5 of National Instrument 43-101.

I have read National Instrument 43-101 and Form 43-101F1 and the items for which I am responsible in this report entitled *Lamaque Complex Technical Report* with an effective date of December 31, 2024, has been prepared in compliance with same.

As of the effective date of the technical report, to the best of my knowledge, information and belief, the items of the technical report that I was responsible for contain all scientific and technical information that is required to be disclosed to make the technical report not misleading

Dated at Montreal, Québec, this 27<sup>th</sup> day of January, 2025.

***"Signed and Sealed"***

Vu Tran

\_\_\_\_\_  
Vu Tran, Eng.